

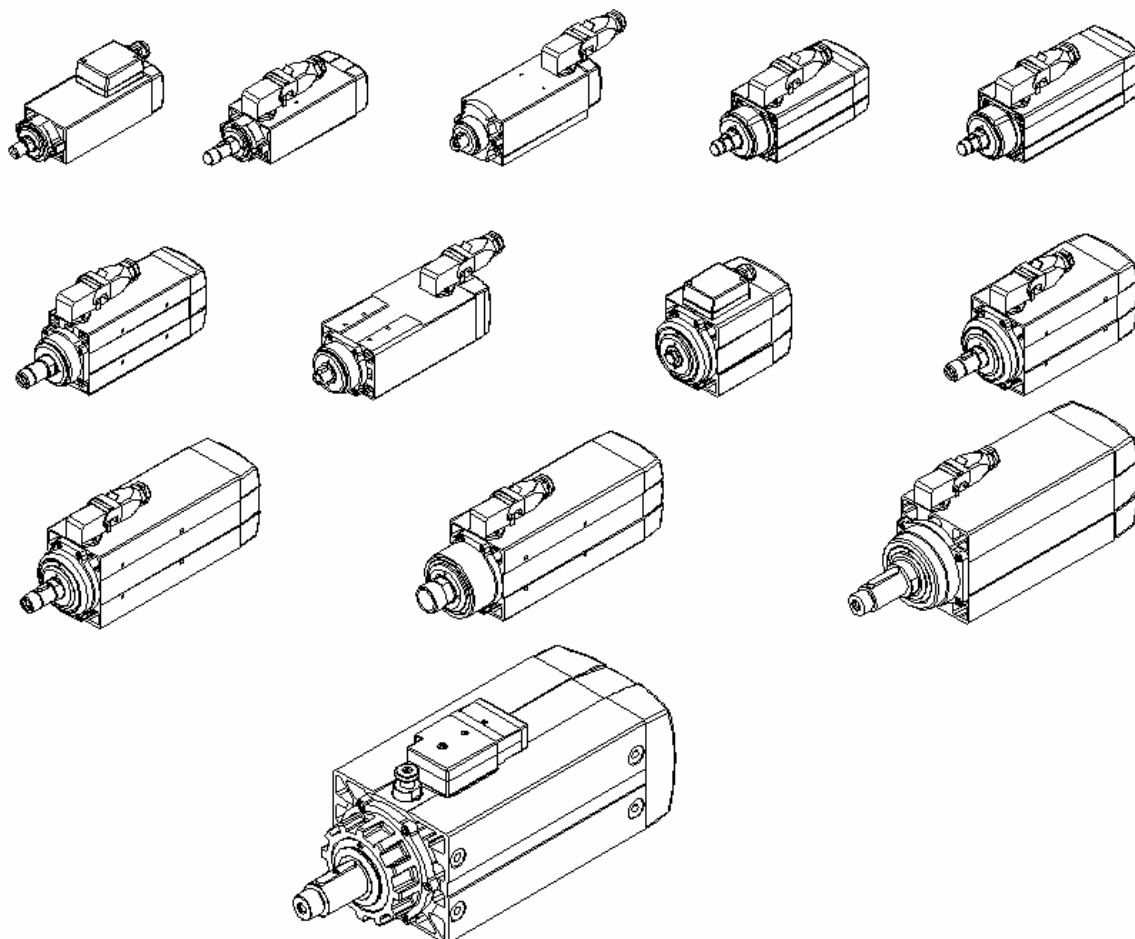

INSTRUCTIONS AND PRECAUTIONS FOR
INSTALLATION, OPERATION AND MAINTENANCE



ELECTRO-SPINDLES

FIMEC

DOCUMENTATION SUPPLIED WITH THE ELECTRO-SPINDLE

The documentation supplied with the electro-spindle comprises a dossier containing:

- this manual giving the instructions and precautions for operation, installation, and maintenance
- a set of other documents including:
 1. Manufacturer's Declaration, in compliance with Appendix IIB of the 98/37/CE Machinery Directive
 2. Data sheet: Electro-spindle overall dimension drawing – Motor specifications and performance curves – Connection drawings (electrical-pneumatic-hydraulic) – Optional accessories – Spare parts.

The Attachments are an integral part of the documentation and must be consulted in conjunction with this manual to avoid missing important information.



CHECK THAT ALL THE ABOVE DOCUMENTS ARE PRESENT WHEN THE ELECTRO-SPINDLE IS DELIVERED.
ASK FIMEC FOR COPIES OF ANY MISSING DOCUMENTS.

ABOUT THIS MANUAL

This manual has been written by the Electro-spindle Technical Office of FIMEC S.p.A., for use by all installers, operators, and service technicians working with FIMEC HT and HM series electro-spindles.

This manual is supplied together with the electro-spindle. At its revision date, it was the most up to date documentation available on this product.

IMPORTANT NOTES

When you start the motor for the very first time and if the motor has not been used for over a month, carry out a brief running in routine with the following times:

5 minutes at 50% of the max. speed

3 minutes at 80% of the max. speed

2 minutes at 100% of the max. speed

With every daily start, ALWAYS PREHEAT THE SPINDLE MOTOR following the next indicated times:

2 minutes at 50% of the max speed

2 minutes at 80% of the max speed

1 minute at 100% of the max speed

This routine allows the bearings and the entire rotating parts to reach the ideal working temperature. It shall then reach the maximum speed shown on the motor plate. If the spindle motor is loaded cold, there is a reduction in the preload of the bearing and they will wear prematurely as a result

INTRODUCTION

1.1 PURPOSE

This manual contains important instructions and precautions, and **must** accompany the electro-spindle at all times since it is essential for the safe operation of the electro-spindle.

Keep this manual safe, and ensure that all persons involved with the electro-spindle know of it and have access to it.

The safety precautions contained herein are designed to ensure the safety of all persons exposed to the residual risks associated with the electro-spindle.

The instructions contained herein provide information necessary for the correct operation of the electro-spindle, as required by the manufacturer.

If any information given in this manual is found to be in conflict with applicable safety regulations, contact FIMEC SPA on +39 059 561617 to request the necessary corrections and/or adaptations.



Make sure that you read and fully understand all the documentation supplied with the electro-spindle to avoid incorrect operation of the unit and unnecessary risks of personal injury.

Keep this manual in a suitable place near the machine, where it will always be readily available to operators for consultation.

	<p>THE ELECTRO-SPINDLE MUST ONLY BE USED FOR THE PURPOSE FOR WHICH IT IS DESIGNED. SAFE OPERATION DEPENDS ON THIS.</p> <p>SAFETY ALSO DEPENDS ON CORRECT INSTALLATION OF THE ELECTRO-SPINDLE, AS DESCRIBED IN THE FOLLOWING SECTIONS OF THIS MANUAL.</p> <p>THE INFORMATION GIVEN IN THIS MANUAL IS THEREFORE ESSENTIAL TO ENSURE THAT THE ELECTRO-SPINDLE IS INSTALLED AND USED SAFELY AND CORRECTLY.</p>
---	--

1.2 GENERAL SAFETY SYMBOLS

In this manual, important instructions or precautions are marked with the following symbols:

	<p>WARNING: IDENTIFIES SITUATIONS THAT COULD LEAD TO PERSONAL INJURY.</p>
	<p>IMPORTANT: IDENTIFIES PARTICULARLY IMPORTANT INFORMATION.</p>

2 GENERAL INFORMATION

2.1 PROPER USE OF THE ELECTRO-SPINDLE

The electro-spindle is designed to operate as part of a machine.

The frame of the machine to which it is fitted must be sufficiently rigid to provide adequate support for the weight of the electro-spindle, and to withstand the stresses caused by machining.

The electro-spindles described in this manual are designed for the low-medium power milling and drilling of wood, fibre-board, plastic, aluminium, etc.. They are also designed only for operation at S1 duty cycle unless special applications permit otherwise. (See data sheet.) Electro-spindle technical specifications vary from one model to another. (See data sheet.)

This manual covers two series of electro-spindle:

1. The **HT SERIES**: These electro-spindles are normally fitted with single radial bearing tool supports and are designed for low speed operation (normally up to 12000 RPM).
2. The **HM SERIES**: These electro-spindles are normally fitted with a single radial bearing* rear tool support, and a front tool support consisting of a pair of conical bearings, and are designed for high speed operation.

* For special applications, or if requested by the customer, the single bearing rear support can be replaced with a pair of conical bearings.

2.2 THE MAIN PARTS OF THE ELECTRO-SPINDLE

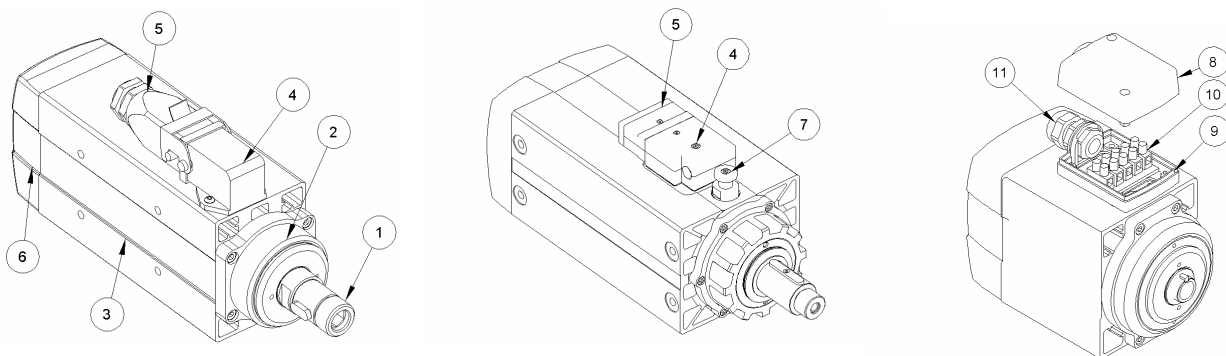



Figure 2.1 Overall views of the electro-spindle

1	Spindle shaft	7	Shaft locking pin
2	Spindle nose	8	Terminal block cover
3	Body	9	Terminal block base
4	Control panel connector	10	Terminal strip
5	Floating control connector	11	Cable guide
6	Cooling fan cover		

2.3 COOLING

In general, the electro-spindle is force air cooled by a fan under the rear cover. This fan is directly keyed on to the spindle shaft. Cooling efficiency therefore depends on spindle rotation speed. Cooling is effective in both directions of rotation. (See data sheet.)

<i>i</i>	THE COOLING FANS ARE DESIGNED BY FIMEC S.P.A. AND PROVIDE MORE EFFECTIVE COOLING THAN TRADITIONAL AXIAL FANS.
	CONTACT FIMEC TECHNICAL OFFICE BEFORE USING THE ELECTRO-SPINDLE AT SPEEDS SIGNIFICANTLY LOWER THAN THOSE SPECIFIED ON THE ELECTRO-SPINDLE DATA PLATE. (SEE DATA SHEET.) WE SUGGEST NOT TO EMPLOY THE SPINDLE MOTORS WITH COAXIAL FANS AT SPEEDS LOWER THAN 7000 RPM. COOLING COULD NOT BE ENOUGH TO COOL THE MOTOR.

Tool fittings

Various types of tool fittings are available to cover most applications. (See data sheet.) These include:

1. spindle shaft with flexible collet
2. spindle shaft with cylindrical fitting, key and externally threaded head
3. spindle shaft with cylindrical fitting, key and internally threaded head
4. spindle shaft with special fitting

All tool fitting types are manually operated. The operator must only fit tools with the spindle shaft stationary.

Tools can be locked by ring nuts, screws, or by expansion systems. Drive is transmitted from the spindle shaft to the tool either by friction (close contact) or by a key.

To lock the tool in the spindle, fit a key in the hexagonal holes accessible through the fan cover on some electro-spindle models or to the flats on the spindle shaft of other models to stop the spindle turning while tightening the tool in place. (See data sheet.)

Certain types of electro-spindle are fitted with a spring loaded pin which can be pushed in to lock the shaft. On these models, turn the shaft slowly by hand while pushing the pin in until it engages.

	<p>MAKE SURE THAT THE RING NUTS AND THE TOOL ARE TIGHT BEFORE STARTING THE ELECTRO-SPINDLE.</p> <p>ON VERSIONS FITTED WITH A TOOL ENGAGEMENT KEY, NEVER START THE ELECTRO-SPINDLE WITHOUT A TOOL IN PLACE AND CORRECTLY TIGHTENED.</p> <p>ON VERSIONS FITTED WITH A SHAFT LOCKING PIN, MAKE SURE THAT THE PIN IS FULLY DISENGAGED FROM THE SHAFT BEFORE STARTING THE ELECTRO-SPINDLE. ALSO ALWAYS MAKE SURE THAT THE ELECTRO-SPINDLE IS FULLY STATIONARY AND NOT POWERED ON BEFORE TURNING THE SHAFT AND ENGAGING THE PIN.</p>
---	--

2.4 IDENTIFYING THE MANUFACTURER

The motor data plate and the serial number punched on the electro-spindle body are the only means of identifying the electro-spindle recognised by the manufacturer. For this reason they must be kept legible throughout the unit's working life.

Electro-spindles are also fitted with other warning and information plates and labels (Figure 2.2).

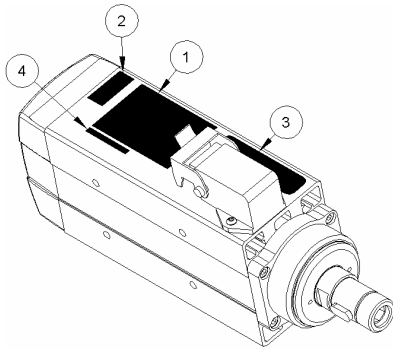

1	Motor data plate
2	Arrow showing direction of shaft rotation
3	Warning label
4	Electro-spindle serial number

Figure 2.2 Typical positions of motor data plate, serial number, warnings and other symbols on the electro-spindle.

Note: The precise position of the motor data plate, serial number and symbols can vary from one model to another.

2.5 CUSTOMER TECHNICAL ASSISTANCE

FIMEC S.p.A.

VIA CARPI RAVARINO 336
41010 LIMIDI DI SOLIERA
MODENA - ITALY
TEL.059/561604 - 059/561617
FAX.059/565309

2.6 TERMS OF WARRANTY

This electro-spindle has been tested and passed at the factory. FIMEC S.p.A. guarantees the unit free from electrical and mechanical defects. This warranty does not cover faults arising from wear of parts normally subject to continuous or rapid wear (e.g. seals, belts, bearings, etc.). In particular, FIMEC S.p.A. provides no guarantee as to the working life of the unit's bearings since this depends on a number of factors such as tool balance, type of machining operation, impacts, and/or other mechanical stresses not specified by the customer.

FIMEC S.p.A. declines all responsibility for non-compliance of the electro-spindle caused by failure to follow the precautions and instructions given in this manual or by improper use or handling of the electro-spindle. The customer has the right to replacement of all parts shown to be defective, unless the said defects are caused by unauthorised tampering, including the fitting of non-original FIMEC spare parts and/or the replacement of parts not described or authorised in this manual unless authorised beforehand and in writing by FIMEC S.p.A..

In no case shall FIMEC S.p.A. or its suppliers accept any responsibility for damage (including but not only, damage to the unit, damage incurred for lost production and income, down-time in manufacturing, loss of information or other economic losses) deriving from the use of FIMEC products, even if FIMEC has been advised of such risks in advance.

The warranty becomes automatically null and void if the customer fails to notify FIMEC S.p.A. in writing of any faults found in the electro-spindle within 15 days of their occurrence. The warranty likewise becomes null and void if the customer fails to permit the electro-spindle's seller to perform all necessary checks and tests, and if, when the seller requests the return of the defective electro-spindle, the customer fails to do so within two weeks of the request.

Dimensioned drawings and photographs are provided only for information purposes and to facilitate understanding of text.

FIMEC S.p.A. has a policy of constant development and improvement, and reserves the right to make functional and stylistic modifications to its products, to change the design of any functional or accessory part, and to suspend manufacturing and supply without notice and without obligation to third parties. Furthermore, FIMEC S.p.A. reserves the right to make any structural or functional change to the units, and to change the supply of spare parts and accessories without any prior notice.

3 WARNINGS AND SAFETY PRECAUTIONS

FIMEC does not and cannot know how end users will install their electro-spindles. The installer or customer must therefore perform risk assessment specific to each installation and application.

It is also the responsibility of the installer to ensure that adequate guards are provided to prevent accidental contact with moving parts.

The installer and the operator must also bear in mind other types of risk, particularly those associated with foreign bodies, explosive, inflammable, toxic or high temperature gasses.

Risks associated with maintenance operations must also be guarded against. Maintenance must be performed in conditions of maximum safety, and only with the electro-spindle fully stationary and switched off.

*Once the electro-spindle has been installed in the way decided upon by the installer and/or customer, the machine becomes a "finished machine" as defined for the purposes of the Machinery Directive. **Overall risk assessment** must therefore be performed on the finished machine and a declaration of conformity produced in compliance with Appendix IIA of the 98/37/CE Machinery Directive.*

3.1 RISKS ASSOCIATED WITH IMPROPER USE AND HANDLING

- Never impede the functioning of, remove, modify or in any way interfere with any safety device, guard, or control of individual parts or of the electro-spindle as a whole.
- Never place your hands, arms, or any other part of your body near moving machinery.
- Never push objects through the cover grill or into the electro-spindle either when it is stationary or when it is operating.
- Do not use the electro-spindle in atmospheres or environments where there is a risk of explosion.
- Unless you are duly authorised, never attempt to repair faults or electro-spindle malfunctions and never interfere in any way with the electro-spindle's operation or installation.
- On completion of servicing work for which guards, covers, or any other protections have been removed, always make sure that they have been correctly and securely replaced and are fully functional before re-starting the electro-spindle.
- Keep all protection and safety devices in perfect working order. Also make sure that all warning and informative plates, labels and symbols are correctly positioned and perfectly legible.
- When troubleshooting the electro-spindle always adopt all the safety precautions listed in this manual for the purpose of preventing injury or damage to persons and things.
- After adjusting any mechanical part, make sure that you fully tighten all screws, bolts or ring nuts you may have slackened or removed.
- Before you start the electro-spindle, make sure that all the safety devices are installed and perfectly functional. Do not start the electro-spindle if this is not the case, but immediately inform the person responsible for machine safety or your direct superior.
- Make sure that you have and use all the personal protective equipment (PPE) required by law. Do not wear loose or hanging clothing (ties, wide sleeves, etc.).
- Never start electro-spindles fitted with tool engagement keys unless a tool is in place and correctly locked. In particular make sure that the key engages the tool correctly.

3.2 RISKS SPECIFIC TO ELECTRO-SPINDLE MAINTENANCE

- During all maintenance and cleaning operations, take great care if a tool is fitted. It is advisable to remove any tool before starting cleaning or maintenance.
- The electro-spindle can still turn under the effect of inertia even after it has been switched off. Make absolutely sure that the electro-spindle is not still spinning before starting any maintenance on it.
- Perform scheduled maintenance as specified in this manual to avoid the risk of mechanical failures from advanced wear.

	<p>NEVER:</p> <p>START ANY MAINTENANCE BEFORE MAKING ABSOLUTELY SURE THAT THE ELECTRO-SPINDLE IS HAS STOPPED SPINNING.</p> <p>START ANY MAINTENANCE ON THE ELECTRO-SPINDLE WITHOUT DISCONNECTING IT FIRST FROM THE ELECTRICAL POWER SUPPLY.</p> <p>ATTEMPT TO CLEAN THE ELECTRO-SPINDLE WHILE IT IS ROTATING.</p>
---	---

4 TECHNICAL SPECIFICATIONS

4.1 GENERAL VIEWS AND OVERALL DIMENSIONS

See data sheet

Please contact FIMEC Customer care service if you need more information (see paragraph 2.5)

4.2 TECHNICAL SPECIFICATIONS AND PERFORMANCE.



WHEN SETTING MAXIMUM CONTINUOUS INVERTER CURRENT, ALWAYS SET THE NOMINAL CURRENT VALUE GIVEN ON THE MOTOR DATA PLATE.

4.3 MOTOR THERMISTOR

In some versions could be inserted a PTC thermistor in the stator windings to monitor temperature. Electrical resistance from the thermistor increases rapidly as it reaches trip temperature (normally 100°C or 130°C depending on the model).

The signal from the thermistor must be fed to a control device to stop the machine in order to protect the electro-spindle from the effects of overheating.

Thermistor trip temperature depends on the model of electro-spindle. (See data sheet)

The thermistors used in these electro-spindles comply with DIN 44081-44082 standards.

Temperature - Resistance curve

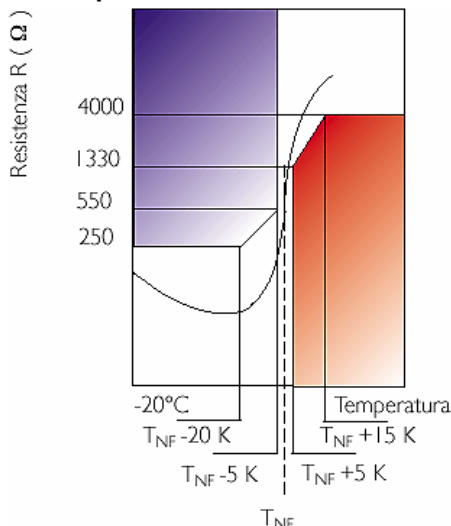

according to DIN 44081/44082

Figure 4.1

Main specifications

Nominal trip temperature T_{NF} = from 50°C to 200°C in steps of 10K or 5K		
Characteristic values for PTC thermistors	Resistance	Measurement voltage
Resistance in temperature range from -20°C to $T_{NF}-20K$	20 to 250Ω	≤ 2.5 V-
Resistance at $T_{NF}-5K$	≤ 550Ω	≤ 2.5 V-
Resistance at $T_{NF}+5K$	≥ 1330Ω	≤ 2.5 V-
Resistance at $T_{NF}+15K$	≥ 4000Ω	≤ 7.5 V- pulse

5 TRANSPORT AND MOVING

5.1 PACKAGING AND LIFTING

UNLESS SPECIFIED OTHERWISE IN THE CONTRACT OF SALE, ELECTRO-SPINDLES ARE NORMALLY COATED IN A FILM OF PROTECTIVE GREASE AND PACKED IN A REINFORCED CARDBOARD BOX TO PREVENT CORROSION AND TO PROTECT THEM DURING TRANSPORT. VERY HEAVY ELECTRO-SPINDLES, OR SHIPMENTS OF MORE THAN ONE UNIT MAY BE PACKED IN CRATES.

Use a clean rag to wipe off the protective grease.

LIFTING AND MOVING ELECTRO-SPINDLES CAN CREATE SITUATIONS OF RISK TO PERSONS NEARBY. ALWAYS FOLLOW THE INSTRUCTIONS PROVIDED BY FIMEC AND ALWAYS USE SUITABLE LIFTING EQUIPMENT.

INSTALLATION AND ASSEMBLY WORK MUST BE PERFORMED ONLY BY SPECIALIST TECHNICIANS.

Always use great care in lifting and moving electro-spindles and their components. Avoid impacts which can damage the body work or cause malfunctioning.

	<p>IT IS THE RESPONSIBILITY OF THE CUSTOMER TO ENSURE THAT THE LIFTING EQUIPMENT USED IS SUITABLE FOR THE PURPOSE IN TERMS OF FUNCTIONING AND LOAD CAPACITY.</p> <p>NEVER LIFT THE ELECTRO-SPINDLE BY ITS FAN COVER. THIS CAN BREAK, DAMAGING THE ELECTRO-SPINDLE AND POSSIBLY CAUSING PERSONAL INJURY.</p>
---	---

5.2 STORAGE

If the electro-spindle is to be stored for any length of time, make sure that it is protected against the elements and in particular against damp, dust, and other forms of damage by the atmosphere or storage environment.

Check on the condition of the electro-spindle periodically, and manually turn the spindle shaft once a month to prevent jamming and deformation.

STORAGE TEMPERATURE: from -5 °C to +55 °C

NON-CONDENSING RELATIVE HUMIDITY: from 5% to 90%

	<p>The storage time limit of FIMEC electrospindles is 12 months.</p> <p>After this time-limit the product must be inspected by an authorized FIMEC service.</p> <p>Please contact FIMEC Customer care service if you need more information.</p>
---	---

6 INSTALLATION

6.1 CHECKING FOR DAMAGE

Before starting installation, check:

- That no part of the electro-spindle has been damaged during transport and/or handling.
- That there is no sign of damp or water inside the connection terminal block.
- That the terminal block and its cover are not damaged in any way.

6.2 PROVISION OF ON SITE INSTALLATION EQUIPMENT

All work in preparation for installation of the electro-spindle is the responsibility of the customer (e.g. preparation of electrical power supplies, compressed air etc.).

MAKE SURE THAT THE ELECTRICAL POWER LINE TO THE ELECTRO-SPINDLE IS OF ADEQUATE SECTION AND POWER. CONNECTION OF THE UNIT TO THE POWER SUPPLY MUST ONLY BE DONE BY QUALIFIED ELECTRICIANS. THE CUSTOMER IS RESPONSIBLE FOR ALL PARTS OF THE ELECTRICAL POWER SUPPLY TO THE ELECTRO-SPINDLE.

The customer is expressly reminded that the electro-spindle must be correctly connected to earth.

Furthermore, the earth connection must comply with applicable regulations in the country in which the unit is installed and must be duly checked and tested by a qualified electrician. (See data sheet.)

6.3 RUNNING IN

THE ELECTRO-SPINDLE IS RUN IN IN THE FACTORY PRIOR TO SHIPMENT. THIS ENSURES CORRECT DISTRIBUTION OF THE LONG-LIFE GREASE IN THE BEARING RACES. THE RUNNING IN CYCLE ALSO INCLUDES COMPREHENSIVE TESTING OF ALL ELECTRO-SPINDLE CONTROL AND SIGNAL DEVICES, AND SIMULATES VARIOUS TYPES OF WORK CYCLE IN THE TEST RIG.

6.4 MECHANICAL CONNECTIONS

6.4.1 ELECTRO-SPINDLE SUPPORT PLANE

i	THE SUPPORTING PLANE ON WHICH THE ELECTRO-SPINDLE IS INSTALLED MUST HAVE A PLANARITY RATING EQUAL TO OR BETTER THAN 0.025MM	 0,025
----------	---	--

6.4.2 FIXING THE ELECTRO-SPINDLE

The electro-spindle must be fixed to the machine carriage or support by means of bolts. Maximum penetration of bolts from the support plate is shown in the overall dimension drawings. (See data sheet)

Figure 6.1 alongside shows an example of electro-spindle fixing holes with permitted bolt penetration dimensions.

The fixing holes on some electro-spindles are through holes, because of the limited thickness of the body. To prevent dust and dirt from entering the unit, these holes are closed off with plastic plugs. These must be removed before the unit can be installed in the machine. These units are also fitted with a plate informing the installer of the maximum allowable bolt penetration depth. (See the example in Figure 6.2)

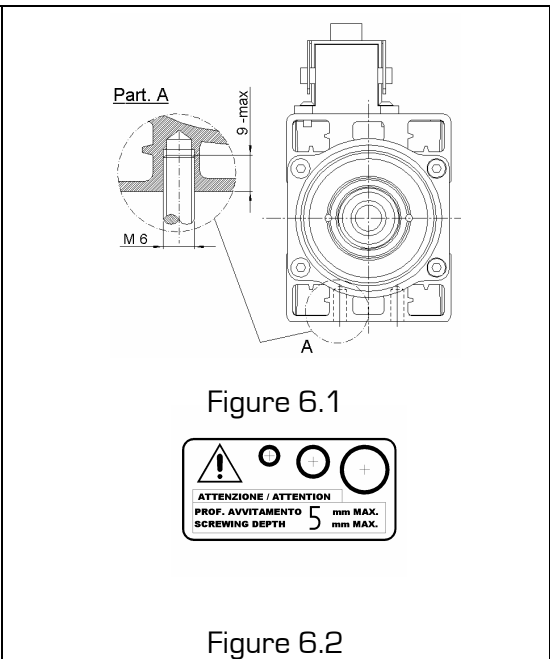

	<p>EXCESSIVE BOLT PENETRATION CAN CAUSE DEFORMATION OF THE ELECTRO-SPINDLE'S BODY, AND MECHANICAL OR ELECTRICAL DAMAGE THAT CAN LEAD TO SPINDLE MALFUNCTIONING.</p> <p>FIXING BOLTS MUST BE TIGHTENED WITH A TORQUE WRENCH.</p> <p>IT IS VERY IMPORTANT TO RESPECT THE TIGHTENING TORQUE SPECIFICATION, SPECIALLY WHEN INSTALLING ELECTRO-SPINDLES ON WHICH ONLY A LIMITED LENGTH OF BOLT CAN BE SCREWED INTO THE FIXING HOLES. FIXING BOLT TIGHTENING TORQUE MUST BE DETERMINED BY THE CUSTOMER ON THE BASIS OF ELECTRO-SPINDLE TESTS IN THE MACHINE IN WHICH IT IS TO BE INSTALLED.</p> <p>EFFECTIVE TIGHTENING TORQUE CAN VARY SIGNIFICANTLY UNDER THE EFFECT OF FRICTION, THE PRESENCE OF GREASE, AND THE SPEED AT WHICH TIGHTENING IS DONE.</p> <p>TIGHTENING TORQUE MUST BE DETERMINED TO SUIT THE APPLICATION TO WHICH THE ELECTRO-SPINDLE IS TO BE PUT.</p> <p>WHILE FIXING THE UNIT IN PLACE, TAKE CARE NOT TO BLOCK OFF THE COOLING FAN GRILL OR OTHERWISE IMPEDE THE FLOW OF COOLING AIR. ALWAYS LEAVE THE MINIMUM GAP AROUND THE UNIT SPECIFIED IN THE OVERALL DIMENSION DRAWINGS. [SEE DATA SHEET.]</p>
---	--

6.5 ELECTRICAL CONNECTIONS

[see data sheet]

	<p>ALWAYS USE POWER CABLE OF ADEQUATE CROSS SECTION FOR THE RATED CURRENT OF THE ELECTRIC MOTOR. [SEE DATA SHEET]</p> <p>NEVER FIT OR REMOVE CONNECTORS WITH THE ELECTRO-SPINDLE POWERED ON.</p>
---	--

6.6 ELECTRIC FAN

The electrospindle is cooled by a rear mounted fan. The fan must be powered up even when the spindle is not operating. The fan is independent of the spindle shaft. This solution gives improved efficiency compared to shaft mounted fans.

	<p>The fan must remain on at all times when the machine is active even if the electrospindle is not operating.</p>
---	--

6.6.1 TECHNICAL SPECIFICATIONS OF THE ELECTRIC FAN

The electric fan is supplied at 24V DC.

For the technical specifications and the electrical connection see the following scheme.

Size 1073

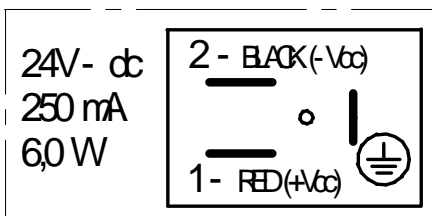

Size 1090

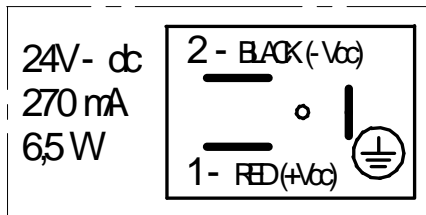
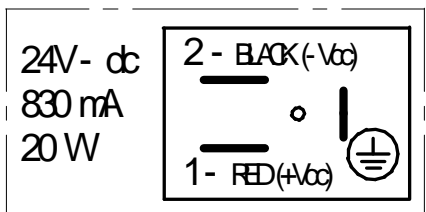
**Size 1120**

7 GENERAL CHECKS AFTER INSTALLATION IN THE MACHINE AND PRIOR TO START-UP

7.1 CHECKING ON THE ELECTRO-SPINDLE PRIOR TO START-UP

Positioning

- Make sure that there is sufficient space behind the electro-spindle's cooling grill. [See data sheet]

Electrical connections

- Make sure that the electro-spindle's earth cable or earthing terminal is connected to the machine's earth.
- Make sure that the signal from the motor's PTC thermistor is suitably processed and connected in series with the machine's stop circuit.

Programming the inverter

- Make sure that the maximum supply voltage value corresponds to that specified on the electro-spindle's motor data plate. [See data sheet.]
- Make sure that the frequency value at maximum voltage corresponds to that specified on the electro-spindle's motor data plate. [See data sheet.]
- Make sure that the maximum frequency value corresponds to that specified on the electro-spindle's motor data plate. [See data sheet.]
- Make sure that the maximum continuous current value **corresponds to that specified on the electro-spindle's motor data plate.** [See data sheet.]
- **Contact FIMEC S.p.A.** if you need to check other inverter parameters.

7.2 CHECKING ON THE ELECTRO-SPINDLE AT THE TIME OF FIRST START-UP

- Run the electro-spindle briefly without load to warm it up [see section 8.2].
- Make sure that the draft of cooling air produced by the fan comes out from all four air channels in the nose of the spindle.
- Make sure that the direction of rotation of the spindle shaft corresponds with the NC and with the direction symbol on the body of the electro-spindle.

8 OPERATION OF THE ELECTRO-SPINDLE

8.1 CLIMATIC LIMITATIONS

Unless specified otherwise, all FIMEC electro-spindles are designed to operate within the following ranges:

- Altitude not above 1000 m above sea level
- Maximum ambient air temperature not above 40°C
- Minimum ambient air temperature not below -5°C

8.2 WARMING UP

Every day, when the electro-spindle is started up for the first time, leave it warm up slowly without load. This ensures that the bearings reach their running temperature gradually, and that the bearing races expand evenly.

The following warming up cycle is recommended:

50% maximum plated speed for 5 minutes.

Warm the electro-spindle up before machining whenever the machine has been left idle long enough for it to cool down to ambient temperature.

8.3 CHOOSING TOOLS

8.3.1 TOOLS

Bear in mind the following recommendations when choosing tools:

- a) Only use fully sharpened tools, and make sure that they are securely locked in the spindle.
- b) Never use bent or damaged tools, chipped tools, or tools that are not perfectly balanced.
- c) Always make sure that the mating surfaces of tools are perfectly clean and dent free before fitting the tool in the tool holder.
- d) Never use tools at speeds in excess of that punched on them or specified by their manufacturer.
- e) Always ensure that the following essential requisites are met before using any tool at high speed:
 - The tool must be of compact, short, and lightweight design.
 - The tool must be a precision instrument, and any inserts must be held in to a high degree of security.
 - The tool must be balanced and must mate symmetrically with the tool holder.
 - The cutting surfaces of the tool must be located near its centre of rotation.

In general, the recommended balance rating for tools run at speeds over 6000 RPM is **G2.5** (ISO 1940 standard).





UNLESS OTHERWISE REQUESTED BY THE CUSTOMER, ELECTRO-SPINDLES WITH TOOL ENGAGEMENT KEY ARE BALANCED WITH THE KEY IN PLACE. (SEE DATA SHEET.)

Because of the many factors to consider, it is not possible to summarise in table form the diameters and maximum weights of tools for any specific speed.

For all special applications, customers should ask FIMEC's Technical Office to perform theoretical calculations using their special calculation software.

Final analysis must always be performed on the machine itself, with the tool correctly fitted, and at the normal operating parameters. Operating vibrations must be measured on the electro-spindle at the points defined in conjunction with our Technical Office.

	MAXIMUM PERMISSIBLE VALUES FOR VIBRATIONS MEASURED ON ELECTRO-SPINDLES MUST FALL WITHIN CLASSES I-K ACCORDING TO ISO 2372 - VDI 2056 STANDARDS.
	<p>ALWAYS CHECK THE MAXIMUM OPERATING SPEED OF TOOLS. THIS IS EITHER PUNCHED ON THE TOOL ITSELF OR OTHERWISE SPECIFIED BY THE TOOL MANUFACTURER.</p> <p>DURING MACHINING, TAKE GREAT CARE TO AVOID CONTACT BETWEEN NON-CUTTING ROTATING PARTS (SPINDLE SHAFT, TOOL RING NUT, ETC.) AND THE WORK. ACCIDENTAL CONTACT CAN LEAD TO DAMAGE TO THE ELECTRO-SPINDLE OR INJURY TO THE OPERATOR.</p> <p>NEVER START ELECTRO-SPINDLES FITTED WITH TOOL ENGAGEMENT KEYS WITHOUT A TOOL IN PLACE AND CORRECTLY TIGHTENED IN THE TOOL HOLDER.</p>
	<p>WITH AT SERIES ELECTRO-SPINDLES IN GENERAL, THE BEARINGS OF BOTH SUPPORTS ARE ELASTICALLY PRE-LOADED TO ELIMINATE THE AXIAL PLAY FROM THE RADIAL BEARINGS AND TO REDUCE VIBRATION AT HIGH SPEED.</p> <p>IF, DURING MACHINING, THE SPINDLE SHAFT IS SUBJECTED TO A FORCE OPPOSITE TO AND IN EXCESS OF THE PRE-LOADING FORCE, THE SHAFT CAN MOVE AXIALLY FOR A VALUE EQUAL TO THE AXIAL PLAY IN THE BEARING, AND VIBRATIONS CAN INCREASE ACCORDINGLY.</p>

9 MAINTENANCE

Read this section carefully before attempting any maintenance on the electro-spindle. This section contains information that is important for the safety of maintenance personnel and for the reliability of maintenance work itself.



All applicable safety precautions must be taken whenever maintenance work is done on the electro-spindle. In particular:

- Maintenance and/or lubrication must be performed only by qualified, expert personnel, with the authorisation of factory management, in compliance with applicable safety directives and standards, and with the use of suitable tools and instruments.
- When performing maintenance, always wear suitable clothing such as tight fitting work overalls and safety shoes. Never wear long or slack clothing or clothes with parts that hang loose.
- When performing maintenance on a machine, cordon it off and mark it clearly with panels stating "MACHINE UNDERGOING MAINTENANCE".

During all maintenance work make sure that the electro-spindle is:

- **disconnected and insulated from the electrical power supply;**
- **fully stopped (not still spinning).**

Maintenance managers must ensure that their team is trained to ensure optimum co-ordination and safety. All persons performing maintenance must remain fully visible to colleagues at all times so that they can signal for assistance if necessary.

	USE ONLY SUITABLE LIFTING AND MOVING EQUIPMENT TO DISCONNECT OR REMOVE HEAVY PARTS FROM THE MACHINE.
	SPECIAL TOOLS ARE NOT NORMALLY REQUIRED FOR ELECTRO-SPINDLE MAINTENANCE.

9.1 SCHEDULED MAINTENANCE - CLEANING THE SPINDLE SHAFT TOOL HOUSING

Always keep the tool housing in the spindle shaft perfectly clean and free from dust, grease, coolant, oil, metal shavings, and corrosion or lime scale.

Dirty housings cause incorrect tool seating, misalignment with respect to the spindle's axis of rotation, and tool slippage (on models without a key). Dirt can also damage the surface of the housing, causing poor machining precision, and causing ***risk of injury to operating personnel!***

For this reason, check regularly (at least once a day if tools are changed frequently) that the surfaces of the spindle shaft, tool housing and tool itself are perfectly clean.

These parts can be cleaned using standard commercial detergents for metal surfaces. When cleaning, take the opportunity to check the condition of the surfaces for wear or damage.

9.2 OCCASIONAL MAINTENANCE

- Clean the grill of the cooling fan and remove any objects blocking the airways.
- Check that the fixing bolts securing the electro-spindle to the machine are tight.



THE BEARINGS ARE LUBRICATED FOR LIFE AND DO NOT REQUIRE GREASING.

9.2.1 REMOVING AND REFITTING COMPONENT PARTS

COMPONENT PARTS MUST BE REMOVED AND REFITTED ONLY BY QUALIFIED PERSONNEL AUTHORISED BY FIMEC S.P.A..



ONLY THE REPLACEMENT OF PARTS WITH ORIGINAL FIMEC SPARES AND THE SUBSEQUENT ADJUSTMENT OF THE NEWLY FITTED PARTS IS AUTHORISED. NO OTHER TYPE OF WORK IS AUTHORISED AND, IF DONE, WILL LEAD TO THE CANCELLATION OF THE WARRANTY.

PLEASE CONTACT FIMEC CUSTOMER CARE SERVICE IF YOU NEED MORE INFORMATION.

10 DISPOSING OF THE ELECTRO-SPINDLE

AT THE END OF THE ELECTRO-SPINDLE'S WORKING LIFE IT IS THE CUSTOMER'S RESPONSIBILITY TO DISPOSE OF IT CORRECTLY. FIRST OF ALL, CLEAN THE UNIT AND SEPARATE THE VARIOUS COMPONENTS INTO MECHANICAL AND ELECTRICAL PARTS. THEN SEPARATE THE COMPONENT PARTS ACCORDING TO TYPE OF MATERIAL: ELECTRIC MOTORS (COPPER WINDINGS), METAL PARTS (BODY, ETC.), PLASTIC PARTS, ETC.. DISPOSE OF THE VARIOUS MATERIALS IN COMPLIANCE WITH THE LAWS AND REGULATIONS APPLICABLE IN THE COUNTRY WHERE THE ELECTRO-SPINDLE HAS BEEN INSTALLED.

11 SPARE PARTS SCHEME

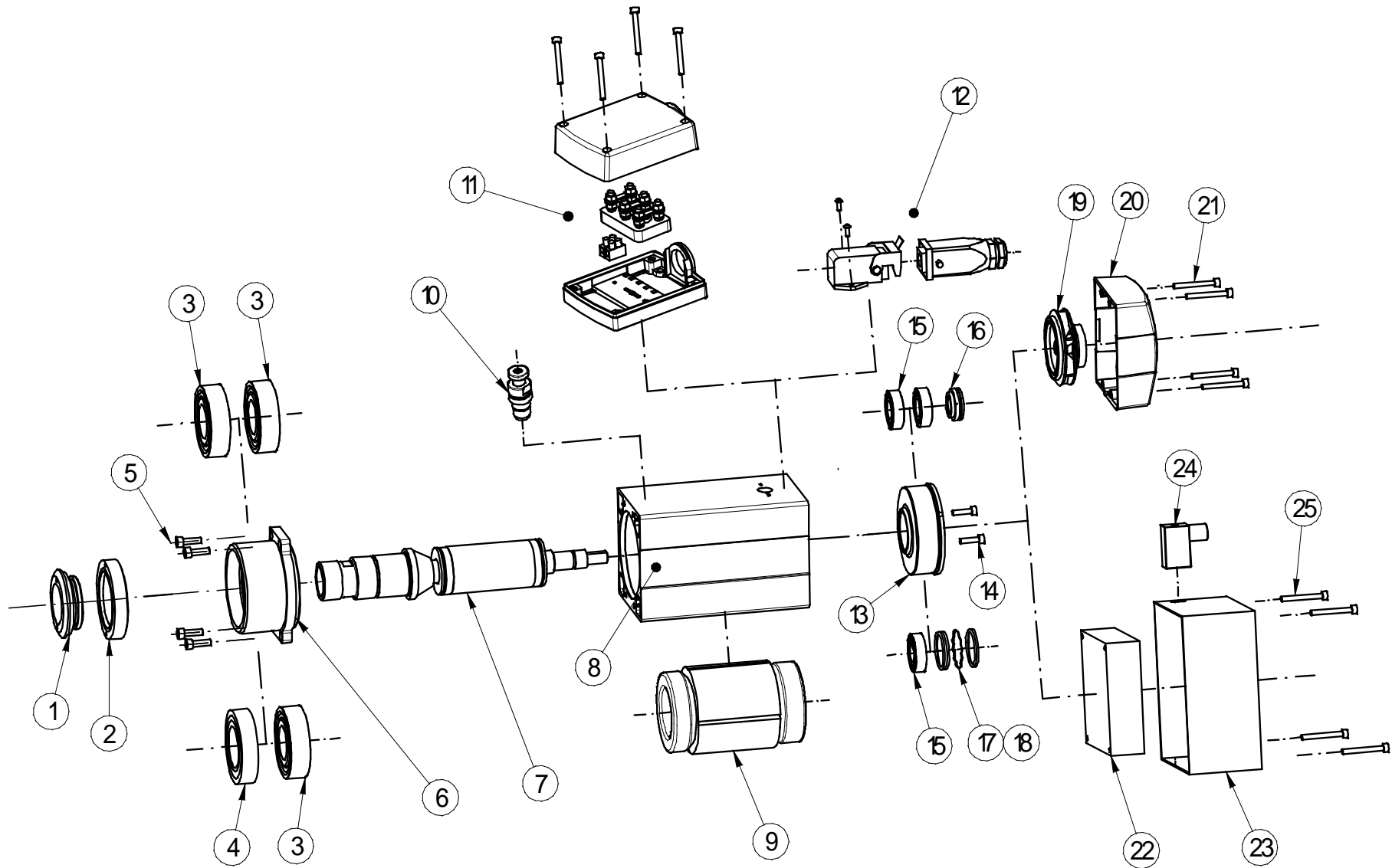

1.	INTERNAL FRONT RING NUT	14.	REAR CAP SCREWS
2.	EXTERNAL FRONT RING NUT	15.	REAR BEARINGS
3.	FRONT BEARINGS	16.	REAR RING NUT
4.	FRONT BEARINGS SPACER	17.	SHIMMING WASHERS
5.	FRONT CAP SCREWS	18.	LMKS CORRUGATED RING
6.	FRONT CAP	19.	TURBOFAN
7.	SHAFT ASSEMBLY	20.	TURBOFAN CASING
8.	FRAMEWORK	21.	TURBOFAN CASING SCREWS
9.	STATOR	22.	ELECTRIC FAN
10.	SHAFT BLOCKING DEVICE	23.	ELECTRIC FAN CASING
11.	TERMINAL BOARD	24.	ELECTRIC FAN CONNECTOR
12.	CONNECTOR	25.	ELECTRIC FAN CASING SCREWS
13.	REAR CAP		

Please contact FIMEC Customer care service if you need more information (see paragraph 2.5).

12 TROUBLE SHOOTING

<i>PROBLEM</i>	<i>PROBABLE CAUSE</i>	<i>CORRECTIVE ACTION</i>
Excessive vibration during machining	<ul style="list-style-type: none"> • Unbalanced tool • Incorrectly fitted tool • Excessive cutting parameters • Incorrect inverter settings • Tools too big or too heavy 	<ul style="list-style-type: none"> • Balance the tool. See section (see data sheet). • Check that the tool is correctly fitted and that the mating surfaces are clean. • Adjust (reduce or increase) the various cutting parameters. • Check the inverter settings. • Try machining with smaller tools.
Bearing noise	<ul style="list-style-type: none"> • Damaged bearings 	<ul style="list-style-type: none"> • Replace the electro-spindle.
The electro-spindle get very hot and is stopped by the PTC thermistor signal	<ul style="list-style-type: none"> • Incorrect inverter settings • Power settings too high • Machining speeds too low for the power requirement • Cooling fan grill blocked • Cooling fan broken 	<ul style="list-style-type: none"> • Set the inverter parameters according to the plated values (see data sheet). • Contact the FIMEC Technical Office. • Check the cooling fan grill and remove any blockage. • Replace the broken fan.