

LINEAR ACTUATORS

TECHNICAL CATALOGUE

MecVel[®]



This page is left intentionally blank.

CERTIFICAT

CERTIFICADO

СЕРТИФИКАТ

認證證書

CERTIFICATE

ZERTIFIKAT



Italia

CERTIFICATO

Nr. 50 100 15736 Rev.001

SI ATTESTA CHE / THIS IS TO CERTIFY THAT

IL SISTEMA DI GESTIONE PER LA QUALITÀ DI
THE QUALITY MANAGEMENT SYSTEM OF

MECVEL S.r.l.

SEDE LEGALE E OPERATIVA:
REGISTERED OFFICE AND OPERATIONAL SITE:

**VIA DUE PORTONI 23
IT - 40132 BOLOGNA (BO)**

È CONFORME AI REQUISITI DELLA NORMA
HAS BEEN FOUND TO COMPLY WITH THE REQUIREMENTS OF

UNI EN ISO 9001:2015

QUESTO CERTIFICATO È VALIDO PER IL SEGUENTE CAMPO DI APPLICAZIONE
THIS CERTIFICATE IS VALID FOR THE FOLLOWING SCOPE OF APPLICATION

**Progettazione, produzione, vendita e assistenza di attuatori lineari
meccanici e martinetti (IAF 17, 19)**

**Design, production, sale and assistance of mechanical linear actuator
and screw jacks (IAF 17, 19)**



SGQ N° 049A

Membro degli Accordi di Mutuo Riconoscimento
EA, IAF e ILAC
Signatory of EA, IAF and ILAC Mutual
Recognition Agreements

Per l'Organismo di Certificazione
For the Certification Body
TÜV Italia S.r.l.

Validità / Validity

Dal / From: **2021-10-25**

Al / To: **2024-05-20**

Francesco Scarlata

Francesco Scarlata

Direttore Divisione Business Assurance
Business Assurance Division Manager

Data emissione /
Issuing Date

2021-10-25

"PRIMA CERTIFICAZIONE / FIRST CERTIFICATION: 2018-05-21 (EMESSO DA ALTRO ODC/ ISSUED BY OTHER CB)"

"LA VALIDITÀ DEL PRESENTE CERTIFICATO È SUBORDINATA A SORVEGLIANZA PERIODICA A 12 MESI E AL RIESAME COMPLETO DEL SISTEMA DI GESTIONE AZIENDALE CON PERIODICITÀ TRIENNALE"
"THE VALIDITY OF THE PRESENT CERTIFICATE DEPENDS ON THE ANNUAL SURVEILLANCE EVERY 12 MONTHS AND ON THE COMPLETE REVIEW OF COMPANY'S MANAGEMENT SYSTEM AFTER THREE-YEARS"

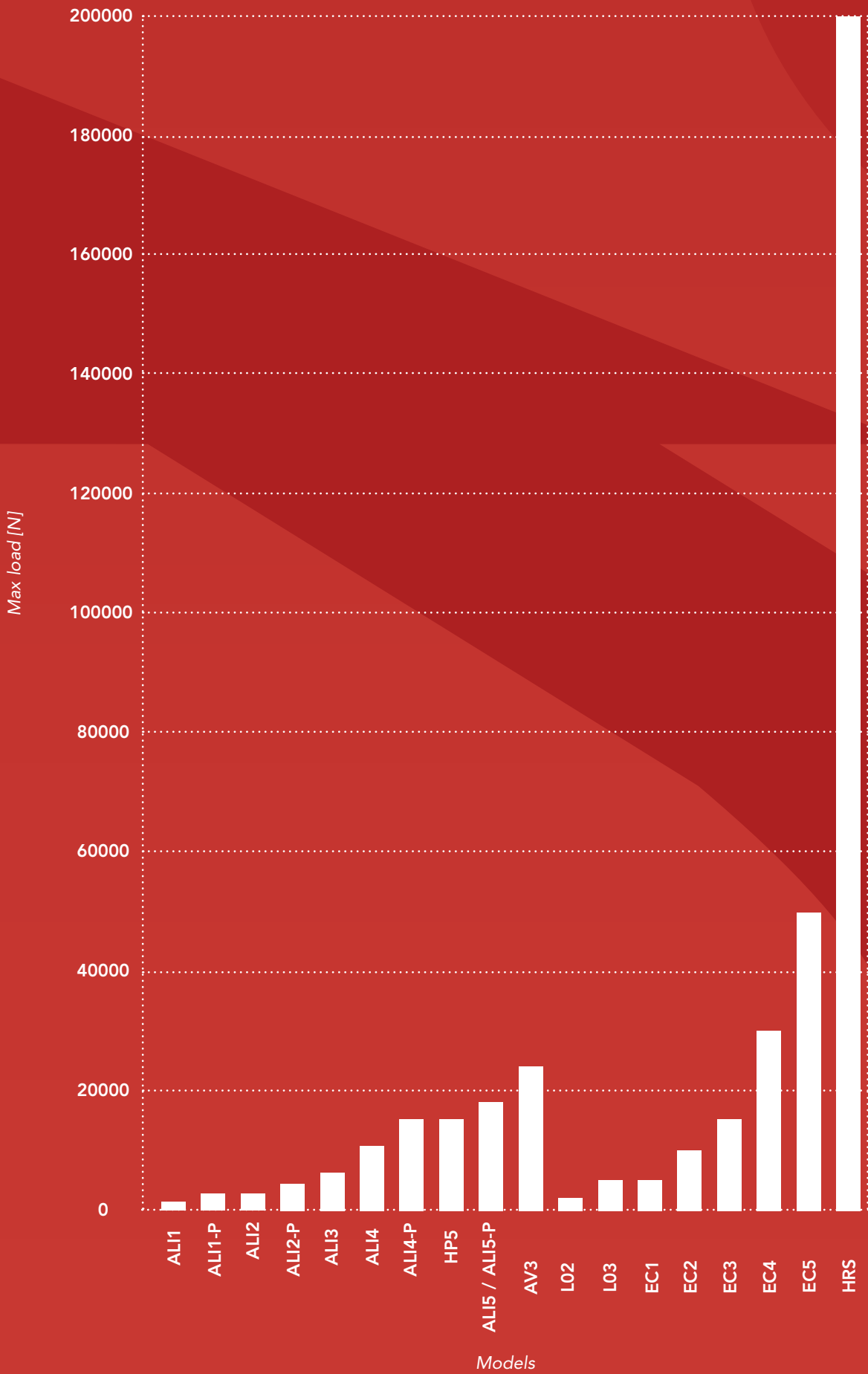

Index

- **SELECTION CRITERIA** 2
- **ALI1** 7
max load 1200 N
max speed 90 mm/s
DC motor
- **ALI1-P** 11
max load 2500 N
max speed 16,5 mm/s
DC motor
- **ALI2** 15
max load 2500 N
max speed 110 mm/s
AC/DC motor
- **ALI2-P** 19
max load 4200 N
max speed 30 mm/s
DC motor
- **ALI3** 23
max load 6000 N
max speed 35 mm/s
AC/DC motor
- **ALI4** 27
max load 10000 N
max speed 100 mm/s
AC/DC motor
- **ALI4-P** 31
max load 15000 N
max speed 48 mm/s
AC/DC motor
- **HP5** 35
max load 15000 N
max speed 20 mm/s
DC motor
- **ALI5** 39
max load 18000 N
max speed 93 mm/s
AC motor
- **ALI5-P** 43
max load 15000 N
max speed 113 mm/s
AC motor
- **AV3** 47
max load 25000 N
max speed 55 mm/s
AC motor
- **L02** 51
max load 2000 N
max speed 30 mm/s
DC motor
- **L03** 55
max load 5000 N
max load 30 mm/s
DC motor
- **EC** 59
max load 5000 - 50000 N
max speed 230 - 15 mm/s
AC motor
- **HRS** 65
max load 200000 N
max speed 65 mm/s
AC motor
- **ACCESSORIES AND OPTIONS** 69
- **SALE CONDITIONS** 86

LINEAR ACTUATORS AND GEAR BOXES SELECTION CRITERIA



GENERAL WARNING

Actuators and gear boxes are devices meant to be installed into larger machines therefore they cannot be considered as safety devices (see EC law CE 89/392 and further CE 91-368,93/44,93/68). They are not elements that shall discriminate, with their use or with their fault, safeguard of people's safety and health. Thus it is not allowed to use MecVel products as safety devices.

INSTALLATION, USE, MAINTENANCE AND WASTE GUIDELINES

MecVel recommendations:

- Actuators and gear boxes being installed by qualified and authorised technicians
- Electrical connections done by qualified personnel; during installation main electric power supply shall be turned off so to run safely all these operations (wearing also protection suits, gloves and glasses)
- Actuators and gear boxes need very few maintenance operations: cleaning and eventually greasing (according to instruction manuals)
- Scheduled inspections to working actuator or gear box in order to detect in time possible problems: in case of doubts contact MecVel
- If something wrong is detected do not try to fix it without MecVel's technical advice: its after-sales dept. will be at your complete disposal to solve it out

All products are delivered with proper packing, according to customer needs and goods dimensions / weight. We recommend a safe product handling, using for example forklifts, safety belts.... Package, as well as the actuators themselves, shall be disposed / wasted according to laws in force in the user's Country.

INTRODUCTION

Linear actuators are independent systems used to obtain linear movements: basically, they are made up by an electric motor, rotating a lead screw directly or by means of a gearbox. A nut is then allowed to move along the lead screw carrying in and out a push rod connected to the nut itself. Load shall be axial only, but it can be tensile or pushing, no matter what push rod direction is. Actuators can work both with or without load. Self-locking or not self-locking behaviour depend on the gearing ratio and load value. In any case, self-locking is always possible with additional components. According to type of actuator and driving / control system used with it, we can have a simple ON / OFF device (pushing and/or pulling) or a servo-mechanism.

Electric actuators main advantages towards pneumatic and hydraulic ones are basically following: they can easily stop in intermediate positions all along their stroke, the power consumption happens only while the actuator is working (not necessary to keep it in position for example), the power supply is clean and easy to find, with no need of tubes. Thus, wirings on applications frameworks will be easier to build and no fluids (i.e. oil) can accidentally be spared. This last feature is necessary in food and textile environments.

ACTUATOR MAIN COMPONENTS

Linear actuators consist in an electric motor directly connected to lead-screw/nut or by means of a worm gearbox, a belt/pulleys system or planetary gearings (1 or 2 stages). The system turns out to be a rigid chain.



RUNNING AGAINST MECHANICAL STOPS CAUSES SERIOUS DAMAGES TO ACTUATOR'S INTERNAL PARTS!

MOTORS

Actuators can host different kinds of motors: AC three or single phase, with brake, inverter-friendly, DC, brushless and stepper-motors. Many options are available such as second shafts, manual brake release and so on.

Selection of motor performances (torque, speed, service...) is done according to duty cycle requested to actuators.

GEAR-BOXES

Two kinds of gear-boxes are basically used on actuators too:

- Steel worm-screw (1 or 2 stages) and plastic or bronze worm-wheel: wheel's material is chosen according to needed main performances such as low noise, lifetime, reduced backlash
- Planetary gear-box (ALI5-AP, L and EC series): due to its high efficiency this kind is often used when duty cycles are high.
- They can have 1 stage with plastic satellites or 2 stages where first one has plastic satellites and second stage has steel ones

LEAD SCREW

Basically steel made and featuring cold-rolled profile, they are coupled with bronze or plastic polymer in order to grant safety and sturdiness against loads. In ball-screw versions (VRS), lead screws are cold-rolled and tempered and coupled with hardened-grinded ball-nuts.

PUSH ROD

Push rods can be aluminium made for actuators whose loads are low, thick chrome-plated steel for those who stand high loads or stainless steel for special applications like in food industries.

ACTUATOR AND GEAR BOX APPLICATION FIELDS

Actuators and gear boxes can be used in several fields and various machineries. To give an example of how different can be the applications needing actuators we can list a few like: adjusting brushes height in floor-sweeping machines, positioning blades for wood-cutting machines, textile industries, paint and chemical plants, medical equipment (different movements in X-ray machines) equipments for disable / aged people, solar panels, etc..

PARAMETERS FOR ACTUATOR OR GEAR BOX SELECTION PROCESS

The main features for actuator or gear box selection are:

- load dynamics (load trend along stroke)
- speed (linear speed trend along stroke)
- duty cycle
- environmental conditions
- stroke length
- power supply
- output rpm (gear box)
- output torque (gear box)

The configuration we get will be self-locking or non-self-locking according to its global efficiency.

LOAD AND LINEAR SPEED

These two parameters shall be evaluated both separately and together since they may affect each other during actuator working cycle, especially if additional elements like inertial phenomena, vibrations ... are involved. For example, if an heavy load has to be moved with changing speeds involving sharp accelerations and slowdowns, inertial load has to be added to physical load, thus affecting actuator choice. In these cases please contact our Technical Dept

Temperature working range can also be widened using special materials for some of the actuator components, special lubricants and seals (the same happens for aggressive environments).Of course under-rating of actuator and duty cycle must also be taken under consideration. In general, ball-screw units are non-self-locking therefore additional devices, such as brakes, can be necessary to lock actuators

DUTY CYCLE AND ENVIRONMENTAL CONDITIONS

These parameters also need to be analyzed as linked together. Duty cycle is defined as percentage rate between on-time and idle-time, on a timeframe of 5 min. Environment is mainly related to temperature and occasional aggressive agents affecting materials (humidity, dust, acids...). Standard actuators duty cycle is rated in S3-30%, at 30°C ambient temp.

Working temperature range allowed for standard actuators is -10°C / +60°C. However duty cycle can be raised building up high-efficiency actuators featuring ball-screws and planetary gearboxes, or over sizing the actuator whose ratings will therefore become higher. Temperature working range can also be widened using special materials for some of the actuator components, special lubricants and seals (the same happens for aggressive environments).Of course under-rating of actuator and duty cycle must also be taken under consideration. In general, ball-screw units are non-self-locking therefore additional devices, such as brakes, can be necessary to lock actuators.

ACTUATOR WORKING STROKE

This feature (standard each 50 mm step) shall be chosen taking under consideration:

- limits tied to high rotation speeds of internal lead screw and to its own weight (in case the actuator is mounted horizontally) (critical Speed diagram is available on any acme screws technical documentation)
- limits linked to lead screw length to avoid buckling problems (see diagram 1 page 10).

Actuator shall than perform its job within its nominal stroke: while designing application / framework, 10mm extra-stroke on both stroke-ends (in and out) shall be included to decrease possibility of going at mechanical stroke.



RUNNING AGAINST ACTUATOR'S MECHANICAL STOPS CAUSES SERIOUS DAMAGES TO ITS INTERNAL

COMPONENTS! In case of strokes 20 times longer than lead screw diameter, 150mm extra stroke shall be included in the design of the actuator so that, when push rod is completely extracted, it has still 150mm more to go: this will give more stiffness to the unit preventing radial backlash.



Excessive radial backlashes lead to side-forces on actuator's axis, thus unexpected wear and lubricant loss, non regular workouts.

POWER SUPPLY

To choose a suitable actuator it is important to start finding out which kind of electric power supply is available. Not all actuators are prepared for all voltages.

SELF-LOCKING

There is not a sharp threshold between self locking and non-self locking conditions, because this feature is affected by gears wear, type of load, presence of vibrations, mounting position etc ...When in doubt the only way of being sure of actuator behaviour is testing it on the application. When actuator is not self-locking, its positioning precision and repeatability features are lower: in this case, some additional elements are required, such as brakemotors, control/feedback systems or motor short-circuit to achieve magnetic braking effect (for DC motors without brake only)

ACTUATOR AND GEAR BOX INSTALLATION

During machine designing it is extremely important to foresee proper mounting points so that actuator won't have to stand radial forces but axial ones only. Then, when physically installing actuator into machinery, an accurate alignment of the connecting points is very important to avoid grease losses and nut wear due to radial forces. Axis of front and back connecting points must always be parallel. Actuators shall work within their nominal stroke. When framework is being designed, 10mm extra stroke (in both directions) must be considered to have less possibilities of mechanical end-stops. Also, when stroke is 20 times longer than lead screw diameter, at least 150mm extra stroke (in extracted position) shall be included in order to prevent the actuator from having radial forces when push rod is completely out.



RUNNING AGAINST MECHANICAL STOP CAUSES SERIOUS DAMAGES TO ACTUATOR COMPONENTS!



Off-set load lead to side-forces on actuator axis causing unexpected wear, lubricant loss and non-regular operation.

Before starting the actuators or gear box up, following checkings shall be performed:

- If actuator is equipped with limit switches devices, before starting the motor, ensure they are connected and working, in order to avoid any mechanical end-stops.
- Make sure push rod will start travelling in the correct direction and limit switches are correctly adjusted. Start motor "step-by-step" to check all this.



ALL WIRINGS OF ACTUATOR (motor and stroke control devices) **MUST BE DONE WITH POWER SWITCHED OFF.** If not, both operator and actuator are at risk.



When actuators are equipped with single-phase motors, capacitors must be discharged before any operation.



In case limit switches are already adjusted, be careful because manual rotation of push-rod will cause adjustment loss!

FOR A CORRECT SELECTION OF ACTUATORS IT IS ABSOLUTELY NECESSARY TO REFER TO ABOVE REPORTED INSTRUCTIONS AND TECHNICAL ADVISES. MECVEL DECLINES ANY RESPONSIBILITY RELETED TO DEMANGES CAUSED TO THINGS AND PERSONS DUE TO NOT PROPER USE OF THE TECHNICAL INFORMATION GIVEN ON THIS CATALOGUE OR INCORRECT USE OF ACTUATORS AND GEAR BOXES. More information about installation of the actuators are reported in the use and maintenance manual.

SERVICE

All actuators with max load lower then ALI5 are long-life lubricated: no relubrication is needed in case actuators workout is regular. Other models are equipped with lubricators and schedules for service are advised into user manual for each actuator.

NUT WEAR CHECK-UP

A scheduled check on nut wear is to be done periodically.

Wire-off motor and put load on push-rod: load value shall be according to model rating (from nominal load till 0,1 times nominal load lowering this coefficient as the actuator size increases).

Applying both compression and tensile load, check by means of an adial-gauge that axial backlash is lower:

$$\text{Backlash (mm)} \leq 0.25 * \frac{\text{screwpitch (mm)}}{\text{starts}}$$

In case backlash is higher actuator needs to be replaced.

If actuator features ballscrew drive, nut fail first signal is noise higher than usual.

A scheduled manual check as explained above is anyway necessary to monitor regular and linear nut workout.



MecVel reserves the right to change products information and/or features without notice; all data contained in this catalogue are purely indicative and not binding for the company.

LINEAR ELECTRIC ACTUATORS
PRODUCTS

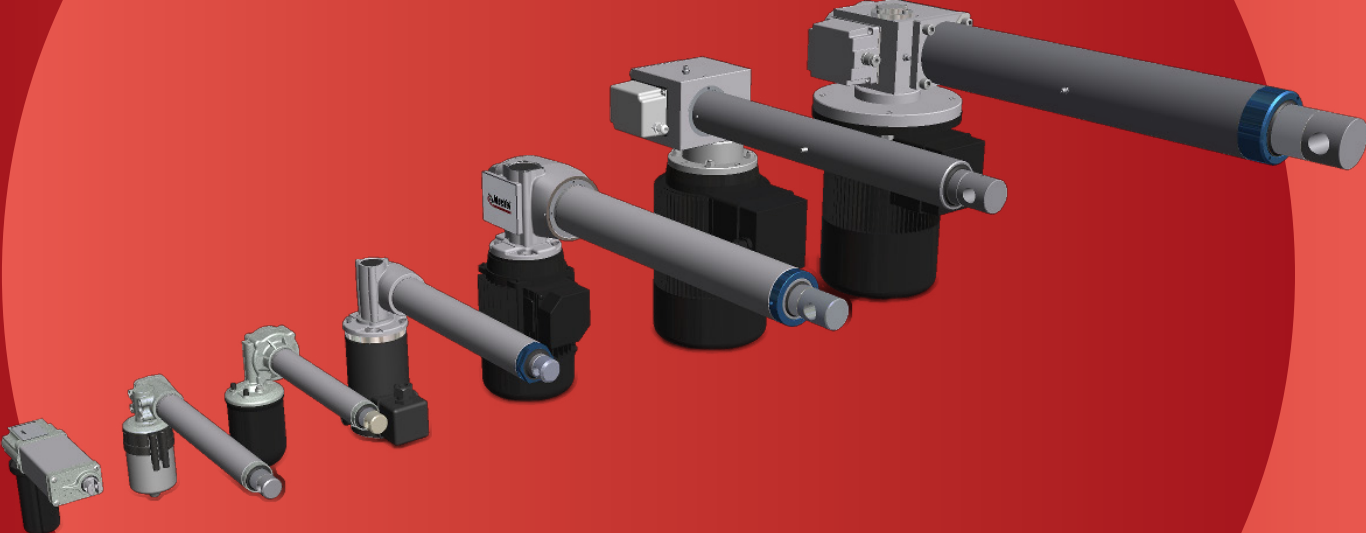



Questa pagina è stata lasciata intenzionalmente vuota.

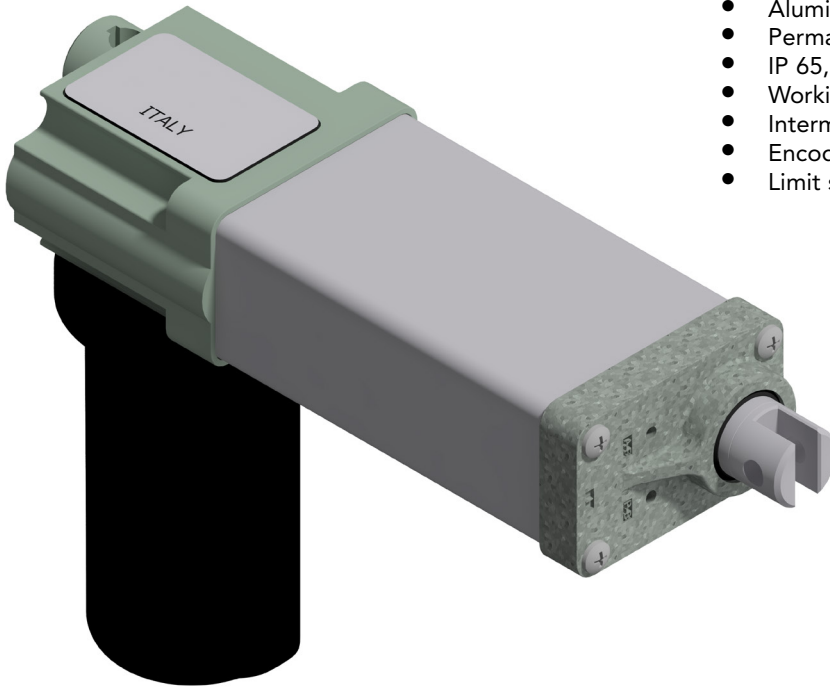

- Permanent magnet motor 12 - 24 Vdc
- Worm gearbox
- ACME lead screw
- Aluminum push rod (Stainless steel on request)
- Permanent grease lubrication
- IP 65, tested according to rule CEI EN 60529
- Working temperature range -10°C +60°C
- Intermittent duty S3 30% (5 min) a 30°C
- Encoder on request
- Limit switches on request

ALI1 (Vdc)					
Fmax (N)	Speed (mm/s)	Version	Motor size	Motor speed (rpm)	Max Current for Fmax(A) 24Vdc**
190 *	90	M13	40	6000	2
270 *	60	M11	40	6000	2
400 *	45	M09	40	6000	2,5
580	30	M06	40	6000	2,5
1200	15	M03	40	6000	3

* When speed is more than 30 mm/s and/or strokes longer than 200 mm, check STROKE SETUP section.

** For 12 Vdc power supply currents are doubled and loads are 20% lower.

BEFORE OPERATING ACTUATOR MAKE SURE YOU READ AND UNDERSTOOD BASIC OPERATIONAL INSTRUCTIONS SHOWN ON USERMANUALS, AVAILABLE FROM WEBSITE.

THIS DOCUMENT DISPLAYS MOST TYPICAL STANDARD FEATURES AND SETUPS: CONTACT OUR OFFICES FOR MORE.

ACTUATOR SHALL NOT COME TO MECHANICAL STROKE-END, TO AVOID FAILURES.
CONSIDER MECVEL's LIMITSWITCHES (MODEL ALI1-F) OR PUT THEM ON MACHINE/FRAME.



MecVel reserves the right to change products information and/or features without notice; all data contained in this catalogue are purely indicative and not binding for the company.

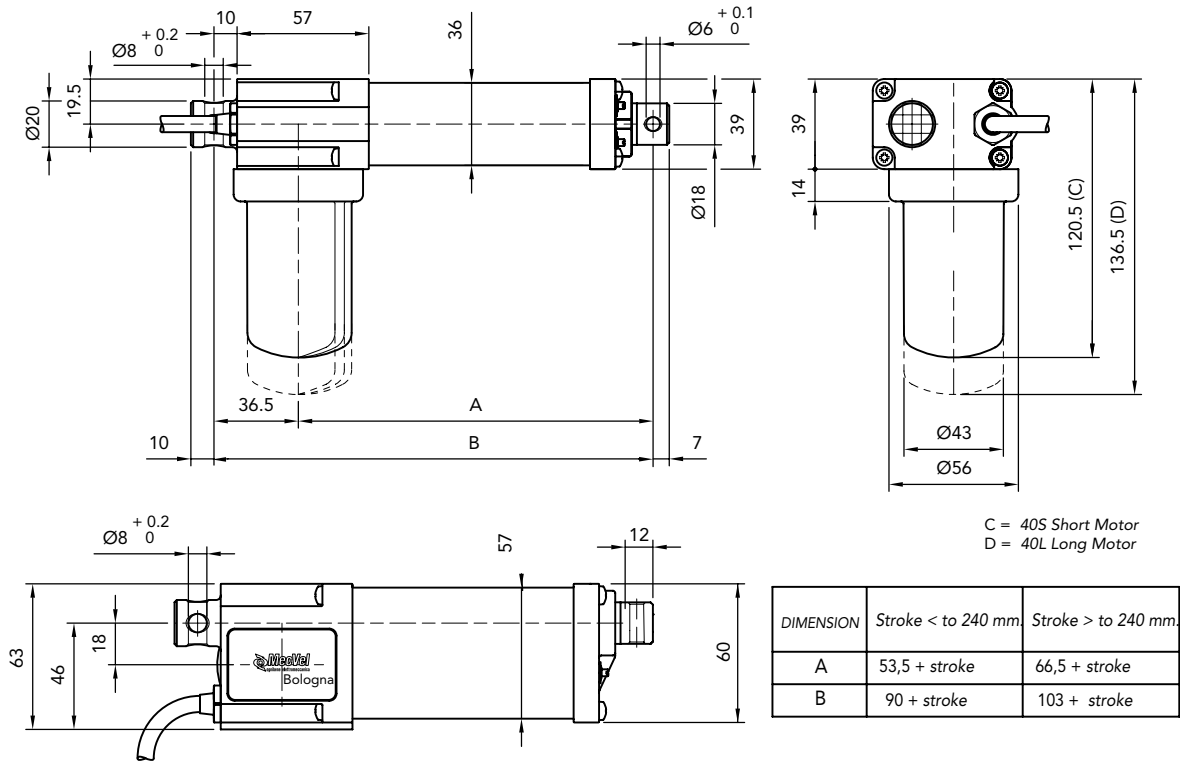

ELECTRICAL WIRINGS

Options available:

- C01/C08 motor
- C02/C09 N° 2 microswitches, diode-wired
- C03/C10 motor + N° 2 micro
- C04/C11 motor + N° 3 micro
- C05/C12 motor + encoder
- C06/C13 N° 2 micro diode wired + encoder
- C07/C14 motor + N° 2 micro + encoder
- C00 special wiring (not standard options)

WARNING:

Micros are actuated by a cam lying on push-rod itself. Micro signal, for speeds higher than 30 mm/s, needs to be handled in its very impulse (I.E. when actuated) and not in its state. Alternatively, MecVel can add a bush to keep the microswitch lever pressed for a longer time avoiding switch signal mistakes, but cause loss of 10 mm of stroke. Connections C02 and C06 make a circuit which stops motor supply, so that the push rod won't overstep the area of the two micros. This system can work only if inertia generated by the actuator and load connected to it does not allow to over-step the micro when stroke is over. So, this works just with low speeds (M01 - M03), with a load opposing the ongoing direction of the push rod. If not, relay or PLC solutions, using C03 and C07 connections, are needed. Wiring diagrams of connections above are following:

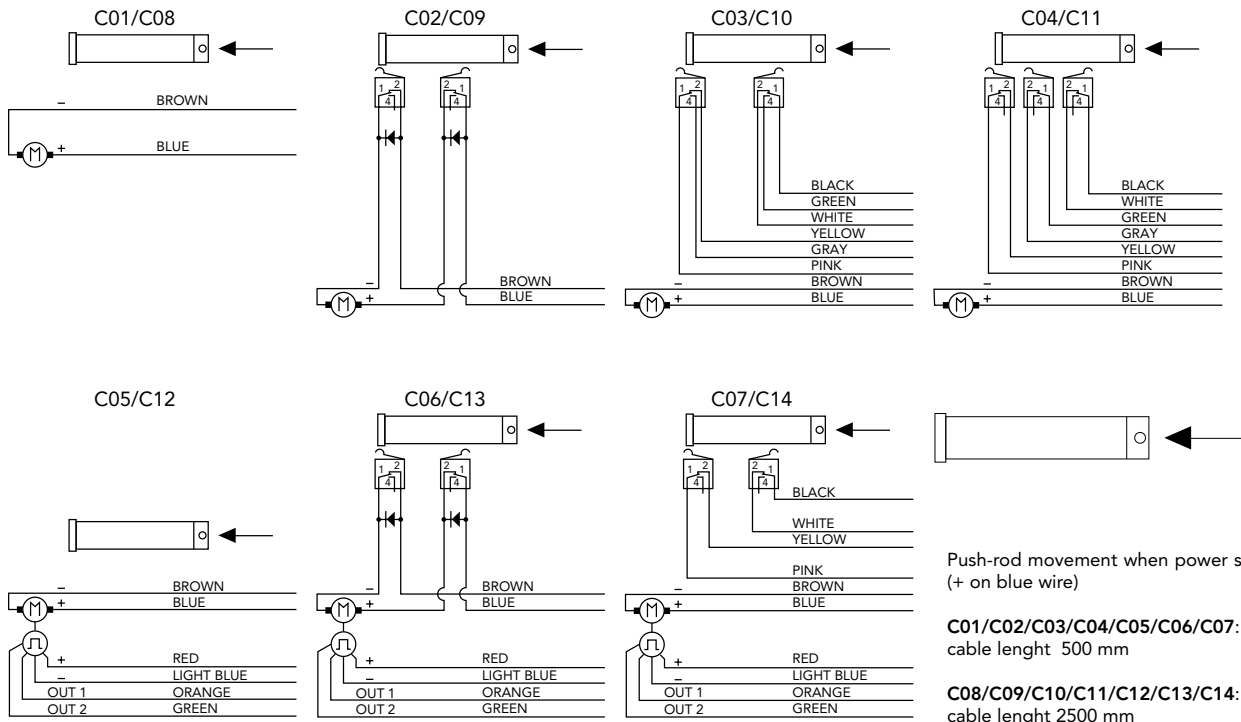

MOTOR POSITION

Motor can be installed on both sides of the actuator, thus achieving two versions, as show below.
The actuator is seen from backwards.

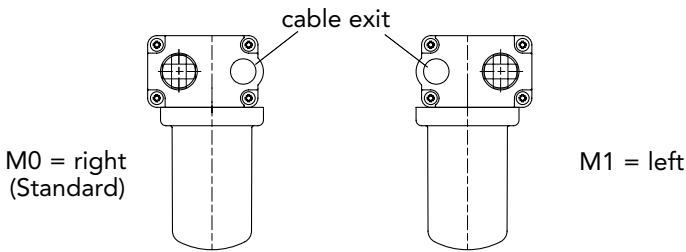

ANTIROTATION DEVICE

Model ALI1-F can host an antirotation device, allowing push rod not to spin when travelling. Front ends A1 and A2 allow for two antirotation settings, AR0 and AR1. When using A3, A4, A5 and A7 front ends antirotation facility must always be mounted.

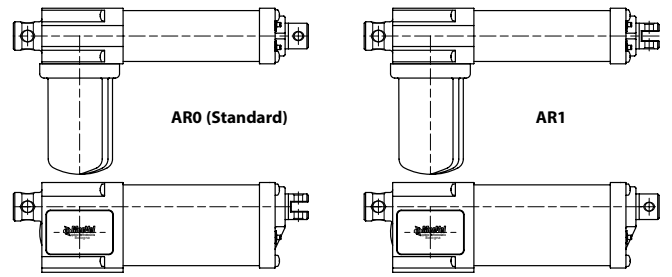

STROKE SETUP

Useful tips for handling stroke and avoid run-on-block collision

- When stroke is more than 350 mm, add 50 mm extra-stroke as guidance, and put corresponding value in ordering-key
- **WARNING SPEED-TIMING ALONG STROKELENGTH:** ramps are extremely important when speed is >30 mm/s!!! Inverter or PWM drive recommended!
- The more speed raises the more extra stroke has to raise too.

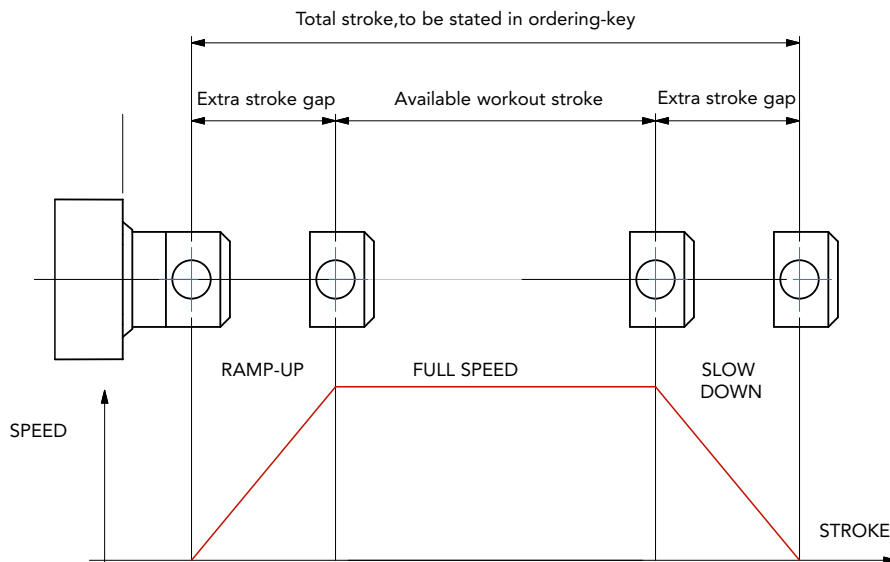

BUCKLING

When stroke is longer than 300mm, BUCKLING can be a risk: please check mounting with our offices and/or see usermanuals.

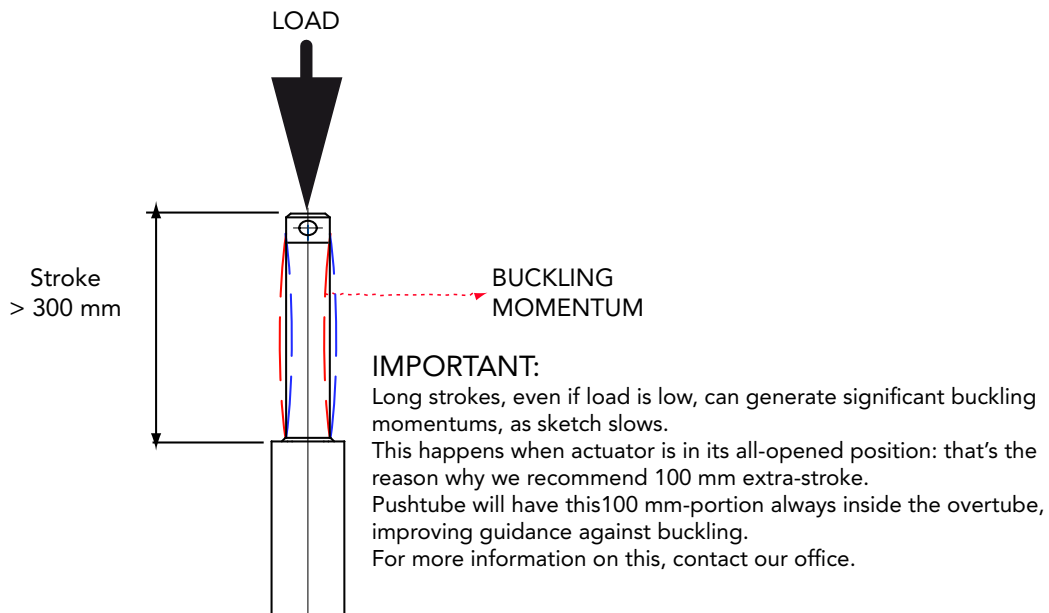

AL11-F/0250/M03/24/M0/C02/P1/A2/
MODEL

ALI1 _____ ALI1-F _____

STROKE (mm)

es. 250 mm = 0250

VERSION

 M03 / M06 / M09 / M11 / M13
 M00 = not standard speed

MOTOR

12 = 12 Vdc 24 = 24 Vdc

MOTOR POSITION

M0 _____ M1 _____

MOTOR OPTIONS

- C01 / C08 Motor
 - C02 / C09 2LS Diode wired
 - C03 / C10 Motor + 2LS
 - C04 / C11 Motor + 3LS
 - C05 / C12 Motor + encoder
 - C06 / C13 2LS diode wired + encoder
 - C07 / C14 Motor + encoder + 2LS
 - C00 Special wiring (not standard option)
- Note: LS (limit switches)

REAR END

P0 = None P1/P2 = standard

FRONT END

A2 = Yoke A3 = Yoke + Clip A4 = Rod end A7 = M8x20 male

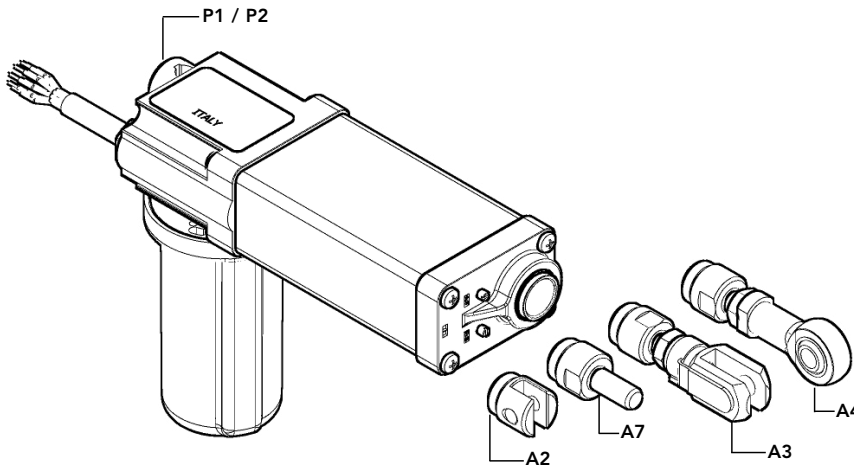
NOTE: COMPLETE THE ORDERING KEY ADDING THE OPTIONS YOU CAN FIND IN THE "ACCESSORIES AND OPTIONS" SECTION

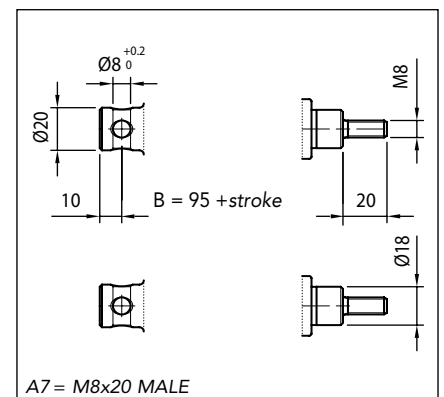
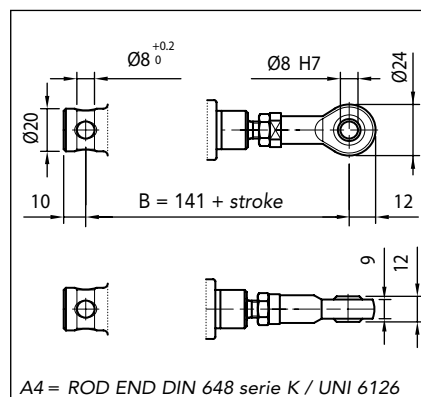
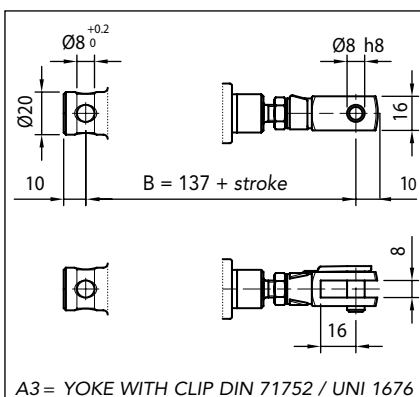
Note: "B" dimension changes according to model

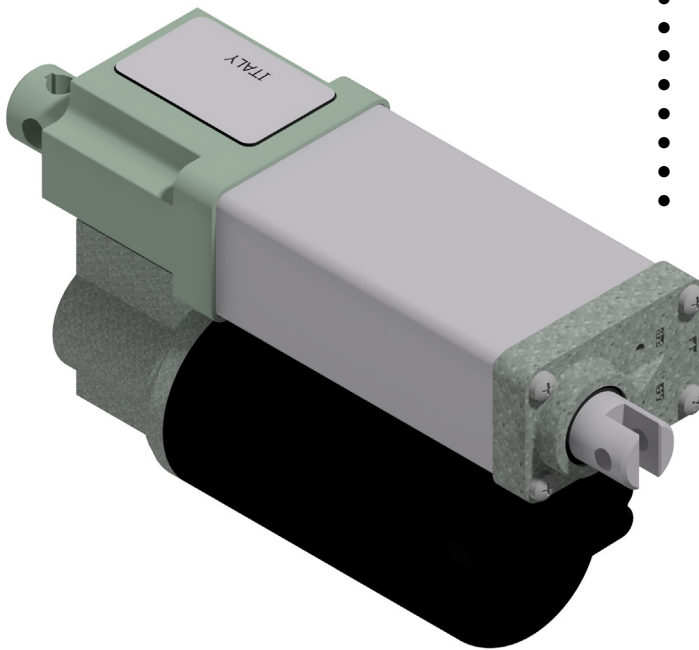
 ALI1-F = See pictures
 ALI1-F stroke > 240 mm = + 13 mm



- Permanent magnet motor 12 - 24 Vdc
- Double worm gearbox
- ACME lead screw
- Aluminum push rod (Stainless steel on request)
- Permanent grease lubrication
- IP 65, tested according to rule CEI EN 60529
- Working temperature range -10°C +60°C
- Intermittent duty S3 30% (5 min) a 30°C
- Encoder on request
- Limit switches on request (ALI1-PF)

ALI1-P (Vdc)					
Fmax (N)	Speed (mm/s)	Version	Motor size	Motor speed (rpm)	Max Current for F max(A) 24Vdc**
1200	16,5	M01	40	6000	2,5
1550	11	M02	40	6000	2
2000	8,3	M03	40	6000	2,5
2500	5,6	M04	40	6000	2,5
2500	2,8	M05	40	6000	1,5
2500	0,9	M06	40	6000	1

When stroke is longer than 200 mm, check STROKE SETUP section.

** For 12 Vdc power supply currents are doubled and loads are 20% lower.

BEFORE OPERATING ACTUATOR MAKE SURE YOU READ AND UNDERSTOOD BASIC OPERATIONAL INSTRUCTIONS SHOWN ON USERMANUALS, AVAILABLE FROM WEBSITE.

THIS DOCUMENT DISPLAYS MOST TYPICAL STANDARD FEATURES AND SETUPS: CONTACT OUR OFFICES FOR MORE.

ACTUATOR SHALL NOT COME TO MECHANICAL STROKE-END, TO AVOID FAILURES.
CONSIDER MECVEL's LIMITSWITCHES (MODEL ALI1-PF) OR PUT THEM ON MACHINE/FRAME.



MecVel reserves the right to change products information and/or features without notice; all data contained in this catalogue are purely indicative and not binding for the company.

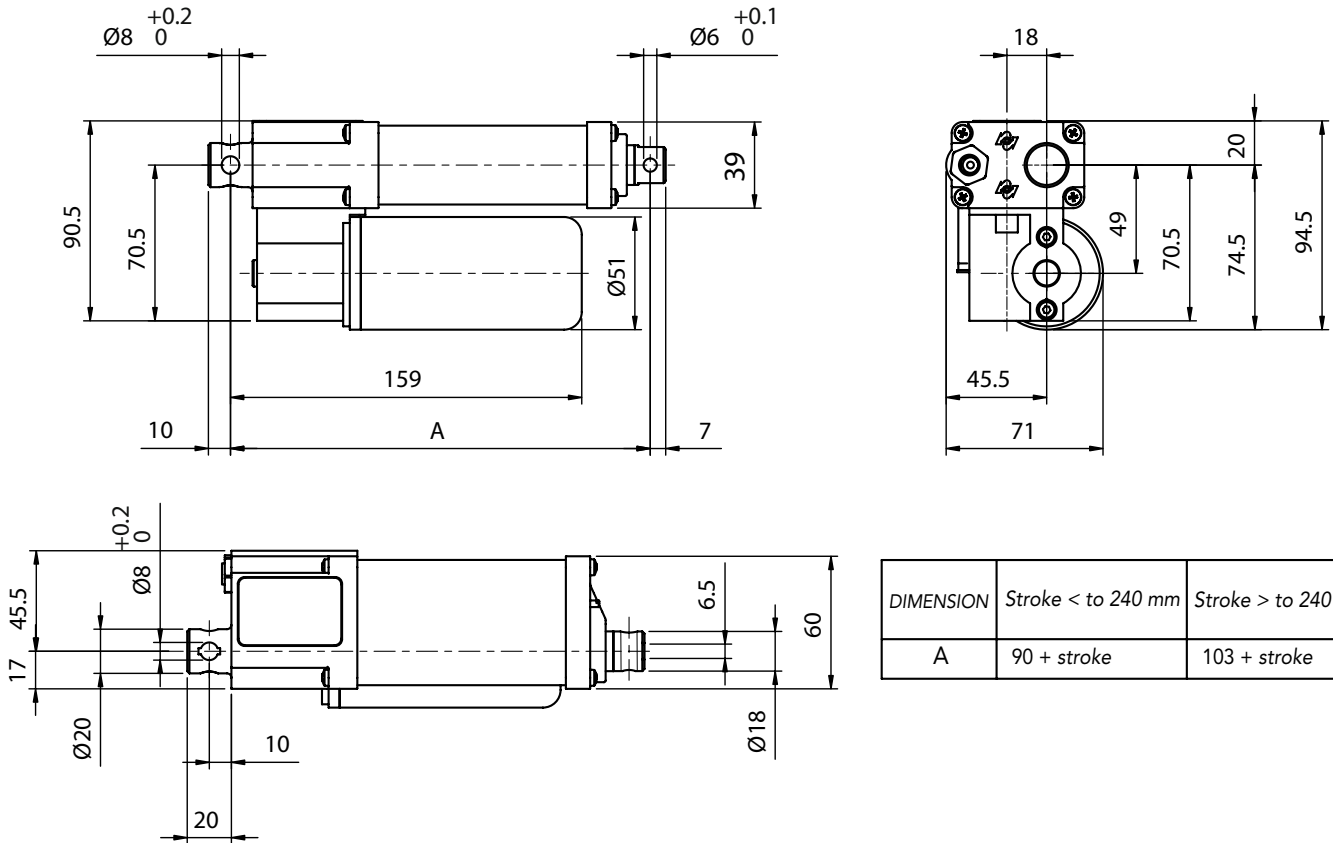

DIMENSION	Stroke < to 240 mm	Stroke > to 240 mm
A	90 + stroke	103 + stroke

ELECTRICAL WIRINGS

Options available:

- C01/C08 motor
- C02/C09 N° 2 microswitches, diode-wired
- C03/C10 motor + N° 2 micro
- C04/C11 motor + N° 3 micro
- C05/C12 motor + encoder
- C06/C13 N° 2 micro diode wired + encoder
- C07/C14 motor + N° 2 micro + encoder
- C00 special wiring (Presence of not standard options)

WARNING

Micros are actuated by a cam lying on push-rod itself. Micro signal, for high speeds needs to be handled in its very impulse (I.E. when actuated) and not in its state. Alternatively, MecVel can add a bush to keep the microswitch lever pressed for a longer time avoiding switch signal mistakes, but cause loss of 10 mm of stroke. Connections C02 and C06 make a circuit which stops motor supply, so that the push rod won't overstep the area of the two micros. This system can work only if inertia generated by the actuator and load connected to it does not allow to over-step the micro when stroke is over. So, this works just with low speeds (M01 - M03), with a load opposing the ongoing direction of the push rod. If not, relay or PLC solutions, using C03 and C07 connections, are needed. Wiring diagrams of connections above are following:

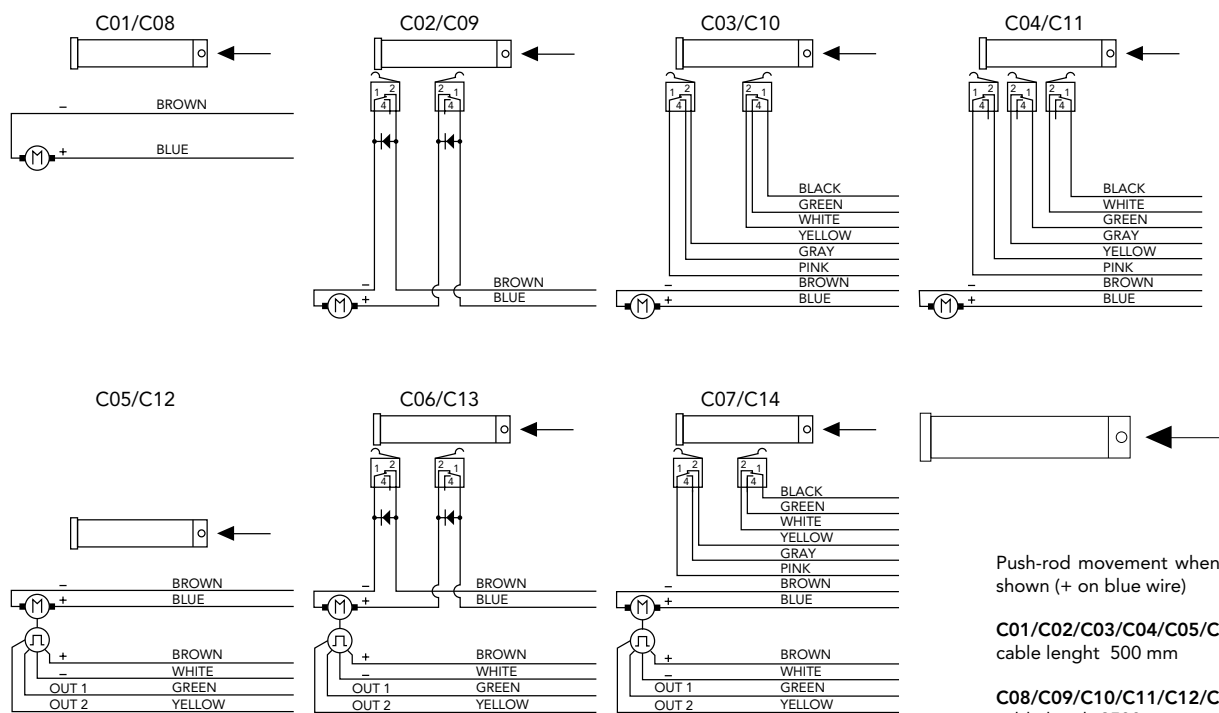

Push-rod movement when power supply is as shown (+ on blue wire)

C01/C02/C03/C04/C05/C06/C07:
cable length 500 mm

C08/C09/C10/C11/C12/C13/C14:
cable length 2500 mm

ANTIROTATION DEVICE

Model ALI1-PF can host an antirotation device, allowing push rod not to spin when travelling. Front ends A1 and A2 allow for two antirotation settings, AR0 and AR1. When using A3, A4, A5 and A7 front ends antirotation facility must always be mounted.

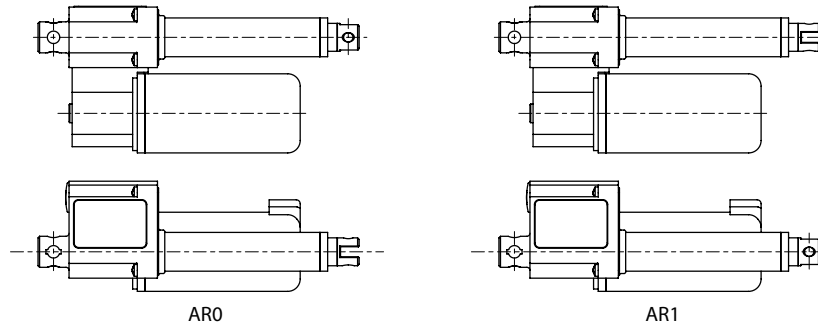

STROKE SETUP

Useful tips for handling stroke and avoid run-on-block collision

- When stroke is more than 350 mm, add 50 mm extra-stroke as guidance, and put corresponding value in ordering-key
- WARNING SPEED-TIMING ALONG STROKELENGTH: ramps are extremely important when speed is >30 mm/s!!! Inverter or PWM drive recommended!
- The more speed raises the more extra stroke has to raise too.

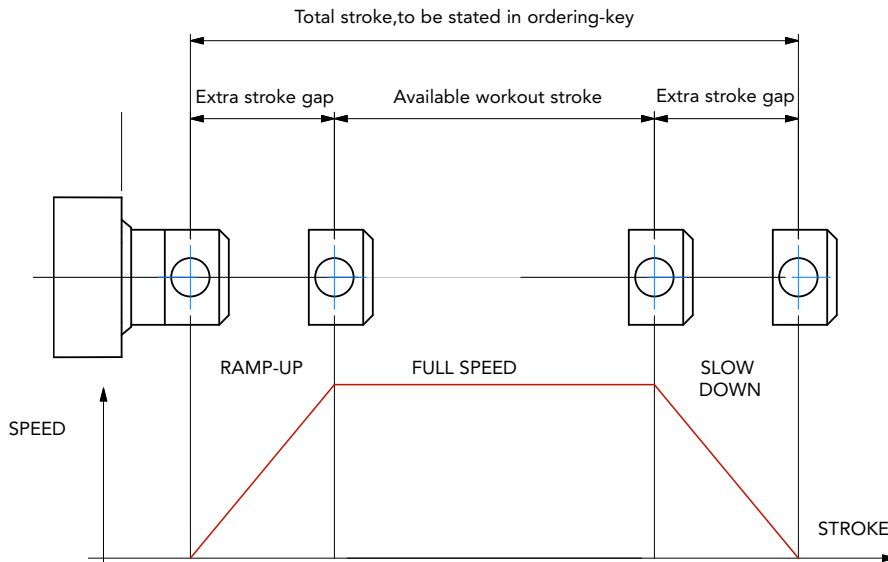

BUCKLING

When stroke is longer than 300mm, BUCKLING can be a risk: please check mounting with our offices and/or see usermanuals.

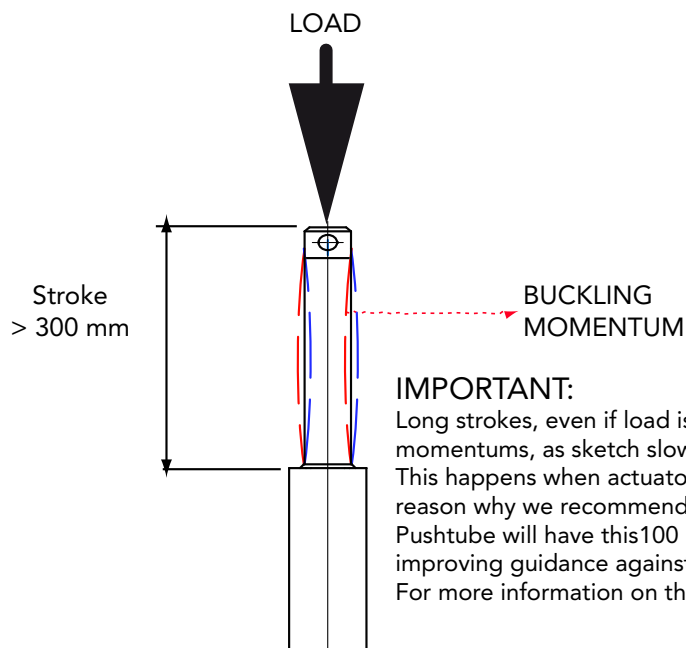

ALI1-PF/0250/M03/24/M0/C02/P1/A2/
MODEL

ALI1-P ALI1-P-F

STROKE (mm)

es. 250 mm = 0250

VERSION

 M01 / M02 / M03 / M04 / M05 / M06
 M00 = not standard speed

MOTOR

12 = 12 Vdc 24 = 24 Vdc

MOTOR POSITION

M0

MOTOR OPTIONS

- C01 / C08 Motor
 - C02 / C09 2LS Diode wired
 - C03 / C10 Motor + 2LS
 - C04 / C11 Motor + 3LS
 - C05 / C12 Motor + encoder
 - C06 / C13 2LS diode wired + encoder
 - C07 / C14 Motor + encoder + 2LS
 - C00 Special wiring (Presence of not standard options)
- Note: LS (limit switches)

REAR END

P0 = None P1/P2 = standard

FRONT END

A2 = Yoke A3 = Yoke + Clip A4 = Rod end A7 = M8x20 male

NOTE: COMPLETE THE ORDERING KEY ADDING THE OPTIONS YOU CAN FIND IN THE "ACCESSORIES AND OPTIONS" SECTION

P1 / P2

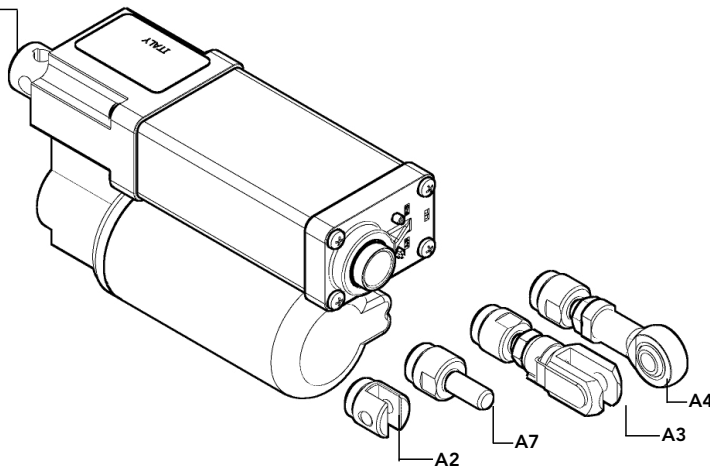
Note: "B" dimension changes according to model

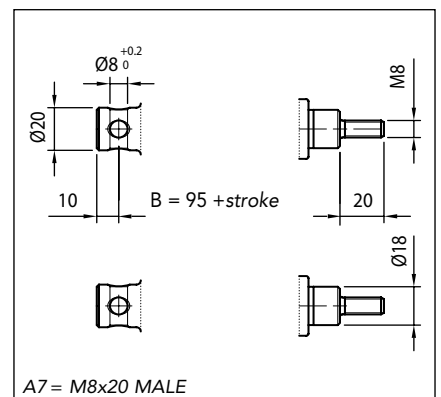
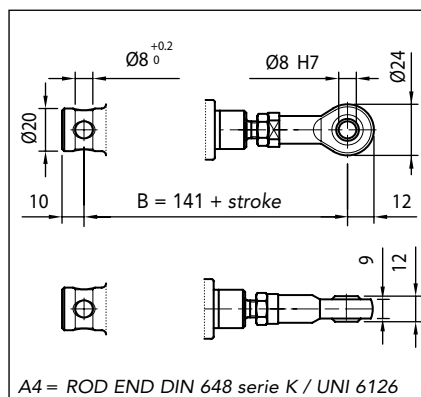
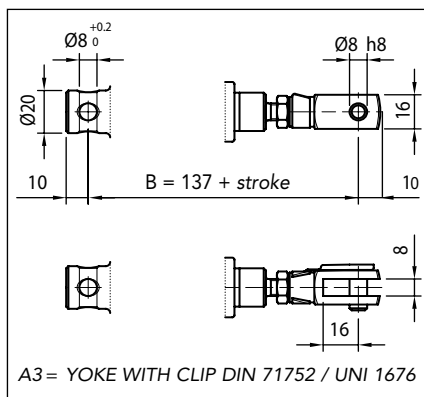
 ALI1-F = See pictures
 ALI1-F stroke > 240 mm = + 13 mm

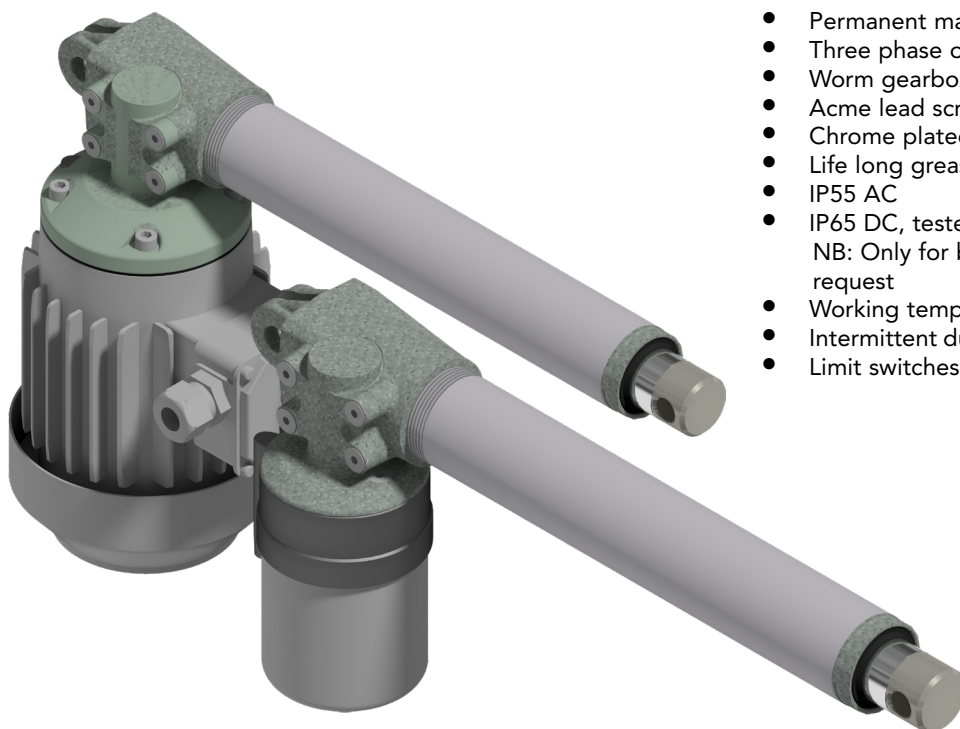

- Permanent magnet CC motor
- Three phase or single phase AC motor
- Worm gearbox
- Acme lead screw or ballscrew (VRS)
- Chrome plated steel push rod
- Life long grease lubricated
- IP55 AC
- IP65 DC, tested according to rule CEI EN 60529
NB: Only for brake motors Standard IP54, IP65 on request
- Working temperature range -10°C +60°C
- Intermittent duty S3 30% (5 min) a +30°C for AC motors
- Limit switches, potentiometer and encoder on request

ALI2 (Vac tri-phase)				
Fmax (N)	Speed (mm/s)	Version	Motor size	Motor power (KW)
450 *	110	M01	IEC56	0.09 2 poles
500 *	70	M02	IEC56	0.09 2 poles
650 *	50	M03	IEC56	0.09 2 poles
850 *	40	M04	IEC56	0.09 2 poles
1000	30	M05	IEC56	0.06 4 poles
1400	20	M06	IEC56	0.06 4 poles
2200	10	M07	IEC56	0.06 4 poles
2500	5	M08	IEC56	0.06 4 poles

ALI2 VRS (Vac tri-phase)				
Fmax (N)	Speed (mm/s)	Version	Motor size	Motor power (KW)
1500 *	45	M01	IEC56	0.09 2 poles
1800	30	M02	IEC56	0.09 2 poles
2000	20	M03	IEC56	0.06 4 poles
2500	10	M04	IEC56	0.06 4 poles
2500	5	M05	IEC56	0.06 4 poles

ALI2 (Vdc)						
Fmax (N)	Speed (mm/s)	Version	Motor size	Motor speed (rpm)	Max Current for F max (A) 24Vdc**	Fs % base 5 min.
800 *	110	M08	59	3000	9	10
1100 *	55	M10	59	3000	7	30
1500 *	40	M11	59	3000	8,5	20
2000	30	M12	59	3000	8,5	20
2500	20	M13	59	3000	8	20
2500	10	M14	59	3000	5	30

With single-phase motors type M (see motor choice guideline in paragraph ACCESSORIES) performances are 20% lower than the three-phase motor.

For the DC models its is possible to add an IP20 break.

* When speed is more than 40 mm/s and/or strokes longer than 350mm, check STROKE SETUP section.

** For 12 Vdc power supply currents are doubled and loads are 20% lower.

→ The brakemotor is strongly recommended

BEFORE OPERATING ACTUATOR MAKE SURE YOU READ AND UNDERSTOOD BASIC OPERATIONAL INSTRUCTIONS SHOWN ON USERMANUALS, AVAILABLE FROM WEBSITE.

THIS DOCUMENT DISPLAYS MOST TYPICAL STANDARD FEATURES AND SETUPS: CONTACT OUR OFFICES FOR MORE. ACTUATOR SHALL NOT COME TO MECHANICAL STROKE-END, TO AVOID FAILURES. CONSIDER MECVEL'S LIMITSWITCHES (MODEL ALI2-F or ALI2-FCM) OR PUT THEM ON MACHINE/FRAME.

 MecVel reserves the right to change products information and/or features without notice; all data contained in this catalogue are purely indicative and not binding for the company.

VERSION WITHOUT LIMITSWITCHES

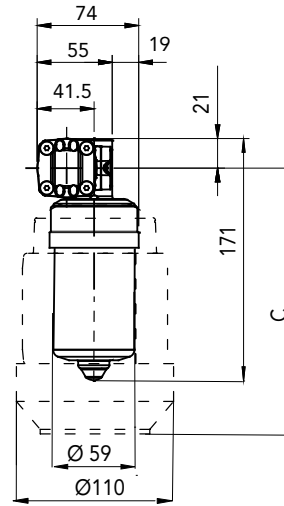
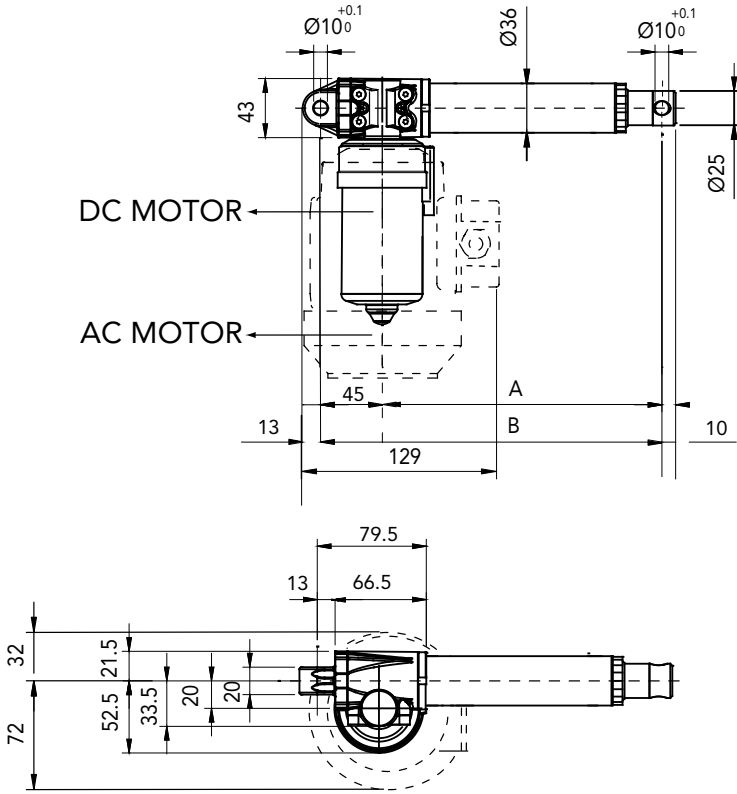

DIMENSION	Stroke < to 320 mm	Stroke > to 320 mm
A	70 + stroke	80 + stroke
B	115 + stroke	125 + stroke
C with brake	254.5	
C without brake	209.5	

VERSION WITH LIMITSWITCHES

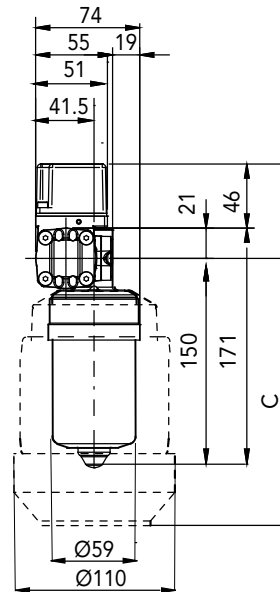
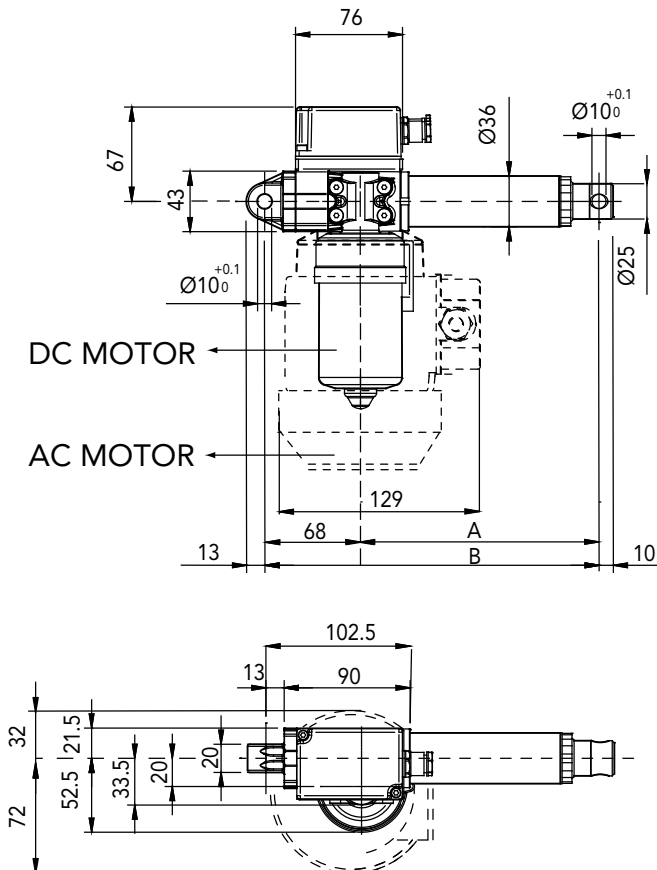

DIMENSION	Stroke < to 320 mm	Stroke > to 320 mm
A	70 + stroke	80 + stroke
B	138 + stroke	148 + stroke
C with brake	254.5	
C without brake	209.5	

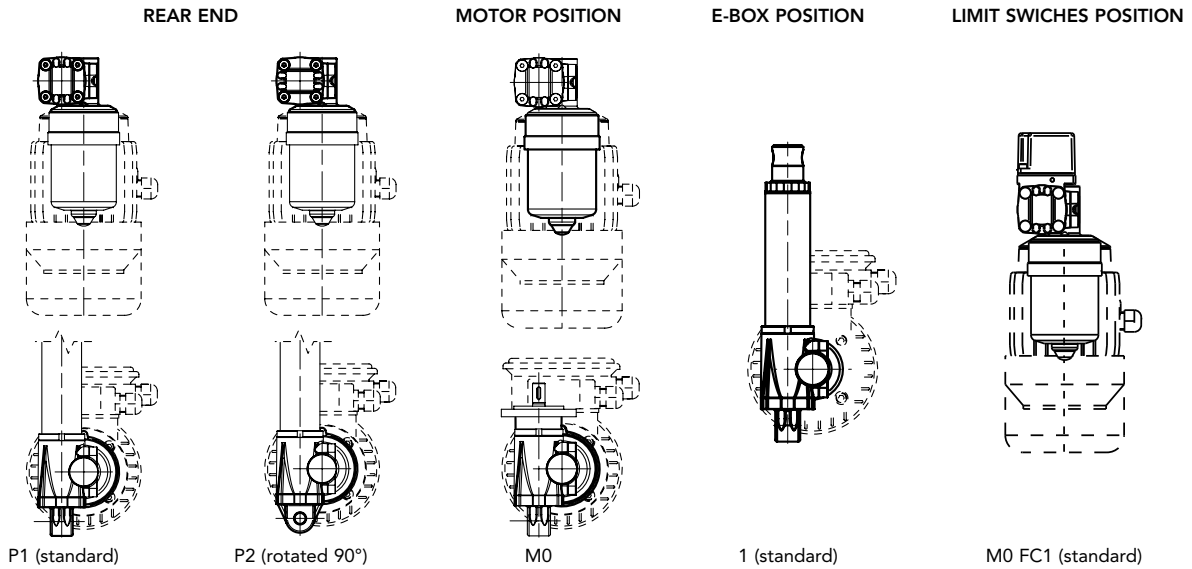

STROKE SETUP

Useful tips for handling stroke and avoid run-on-block collision.

- When stroke is more than 350 mm, add 50 mm extra-stroke as guidance, and put corresponding value in ordering-key.
- **WARNING SPEED-TIMING ALONG STROKELENGTH:** ramps are extremely important when speed is >30 mm/s!!! Inverter or PWM drive recommended!
- The more speed raises the more extra stroke has to raise too.

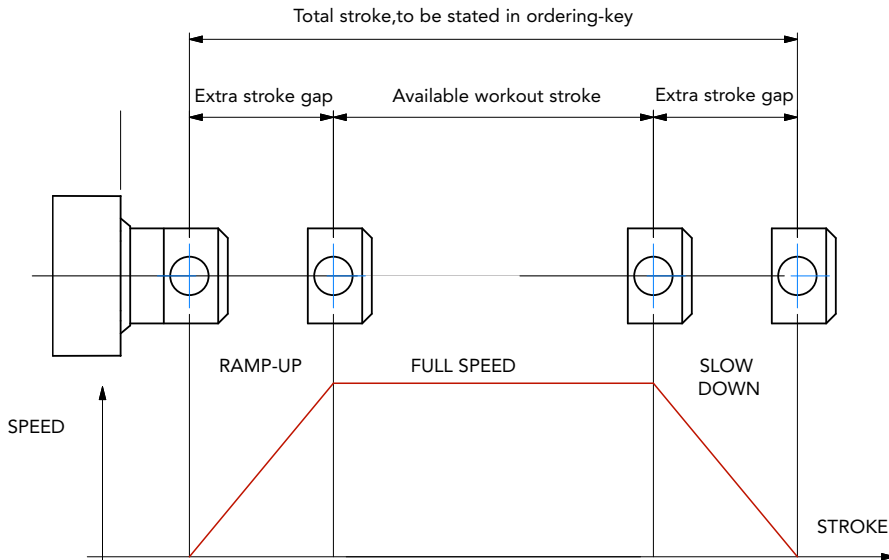

BUCKLING

When stroke is longer than 500mm, BUCKLING can be a risk: please check mounting with our offices and/or see usermanuals.

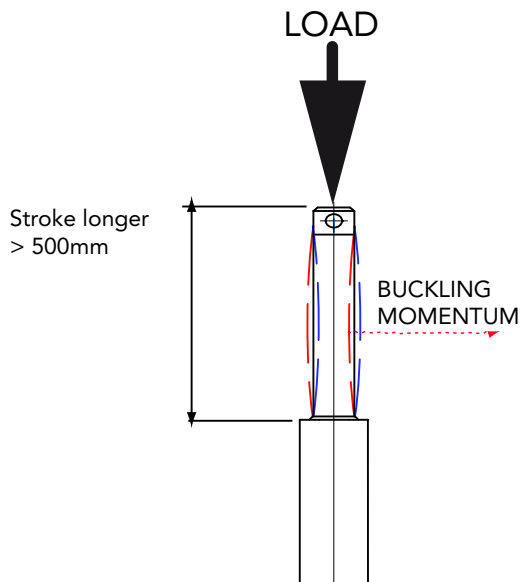

IMPORTANT:

Long strokes, even if load is low, can generate significant buckling momentums, as sketch slows. This happens when actuator is in its all-opened position: that's the reason why we recommend 100 mm extra-stroke. Pushtube will have this 100 mm-portion always inside the overtube, improving guidance against buckling.

For more information on this, contact our office.

ALI2/0250/M04/CA-400/50-T-56-2-0,09/AB/M0/1/E06/2FC1/POT01A/FC1/P1/A1/

MODEL _____
 ALI2 / ALI2-F / ALI2-VRS / ALI2-F-VRS / ALI2-FCM / ALI2-FCM-VRS

STROKE (mm) _____
 es. 250 mm = 0250

VERSION _____
 M08 / M10 / M11 / M12 / M13 / M14 (DC)
 M01 / M02 / M03 / M04 / M05 / M06 / M07 / M08 (AC)
 M00 = Not standard speed

MOTOR _____
 A.C. version, voltage, type, size, n°pole, power
 D.C. version, voltage, size, Rpm

AC MOTOR OPTION _____
 No motor or DC motor: leave all following parameters blank
 Protection Degree: IP65, for selfbrake motor IP54 standard
 Brake type: for brakemotors only: ES. FECA
 Options: Advise if needed (ES. AB 2'shaft)

MOTOR POSITION _____
 M0 None: Leave blank

E-BOX POSITION _____
 1

ENCODER (Pag. ACCESSORIES) _____
 Options pg.76 None: Leave blank

LIMIT SWITCHES (Pag. ACCESSORIES) _____
 2FC1 None: Leave blank

POTENTIOMETER (Pag. ACCESSORIES) _____
 POT01A (1Kohm) POT10A (10Kohm) None: / Leave blank

LIMIT SWITCHES POSITION _____
 FC1 None: Leave blank

REAR END _____
 P1 = Eyelet (standard) P2 = Eyelet (90°)

FRONT END _____
 A1 = Eyelet A3 = Yoke + Clip A4 = Rod end A7 = M10 male

NOTE: COMPLETE THE ORDERING KEY ADDING THE OPTIONS YOU CAN FIND IN THE "ACCESSORIES AND OPTIONS" SECTION

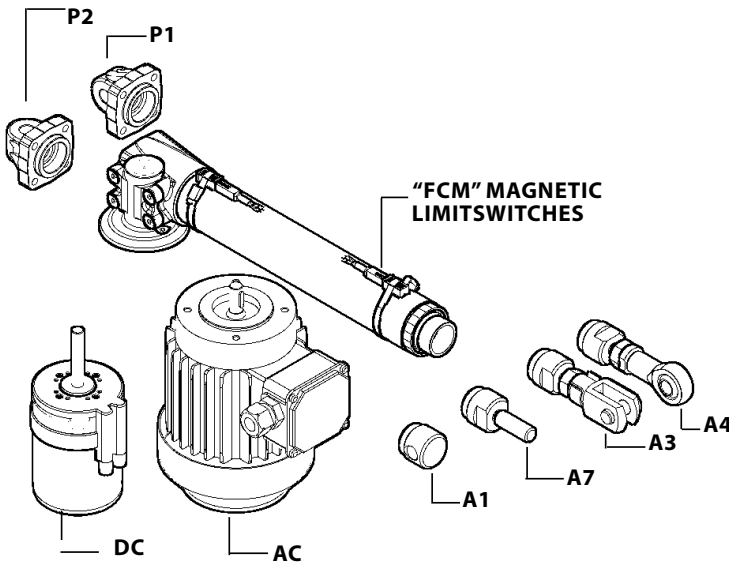

Note: "B" dimension changes according to model

- ALI2 = See pictures
- ALI2 stroke > 320 mm = + 10 mm
- ALI2-FCM = + 34 mm
- ALI2-FCM stroke > 320 mm = +44
- ALI2-F = + 23 mm
- ALI2-F stroke > 320 mm = + 33 mm
- With safety nut "G" = + 30 mm
- ALI2-VRS = + 40 mm
- ALI2-F-VRS = + 63 mm
- Bellows + 20mm

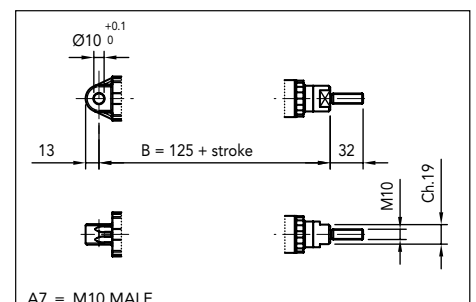
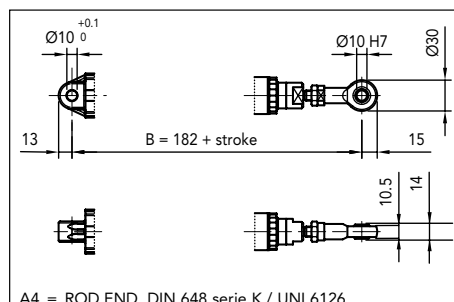
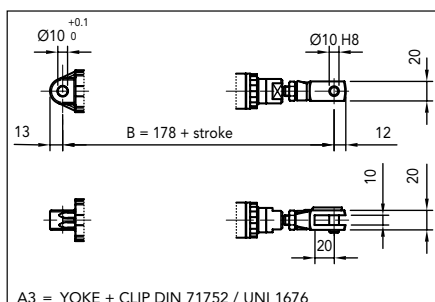

- Permanent magnet motor 12-24 Vdc
- Double worm gearbox
- Acme lead screw or ballscrew (VRS)
- Chrome plated steel push rod
- Permanent grease lubrication
- IP 65, tested according to rule CEI EN 60529
- Working temperature range -10°C +60°C
- Limit switches, potentiometer and encoder on request

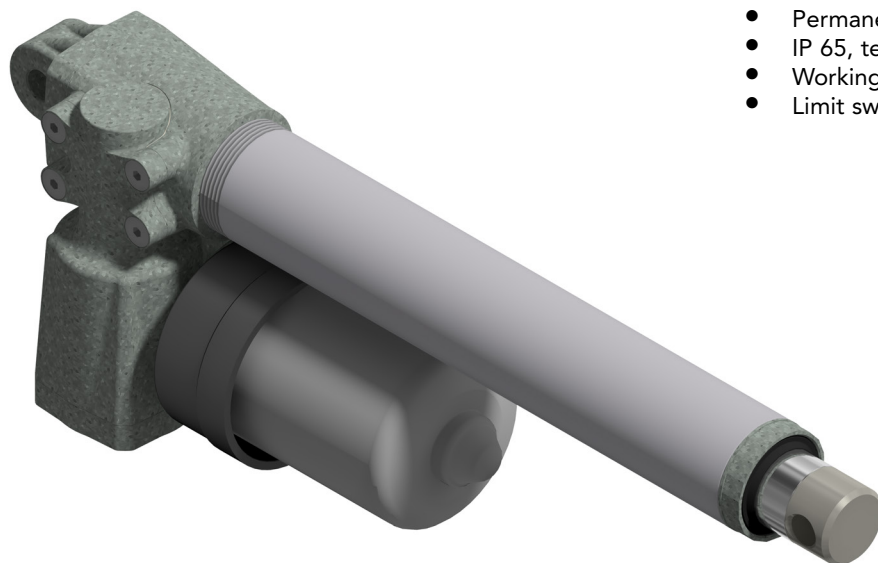

ALI2-P (Vdc)						
Fmax (N)	Speed (mm/s)	Version	Motor size	Motor speed (rpm)	Max Current for F max(A) 24Vdc **	Fs % base 5 min.
2400	30	M01	59	4000	9,5	10
3000	15	M03	59	4000	7	30
4200	10	M04	59	4000	9,5	10
4200	7	M05	59	4000	7	30
4200	2.5	M07	59	4000	3	30
4200	0.6	M09	59	4000	1	30

When strokes are longer than 350mm, BRAKEMOTOR IS RECOMMENDED

** For 12 Vdc power supply currents are doubled and loads are 20% lower.

BEFORE OPERATING ACTUATOR MAKE SURE YOU READ AND UNDERSTOOD BASIC OPERATIONAL INSTRUCTIONS SHOWN ON USERMANUALS, AVAILABLE FROM WEBSITE.

THIS DOCUMENT DISPLAYS MOST TYPICAL STANDARD FEATURES AND SETUPS: CONTACT OUR OFFICES FOR MORE.

ACTUATOR SHALL NOT COME TO MECHANICAL STROKE-END, TO AVOID FAILURES.
CONSIDER MECVEL's LIMITSWITCHES (MODEL ALI2-F or ALI2-FCM) OR PUT THEM ON MACHINE/FAME.



MecVel reserves the right to change products information and/or features without notice; all data contained in this catalogue are purely indicative and not binding for the company.

VERSION WITHOUT LIMITSWITCHES

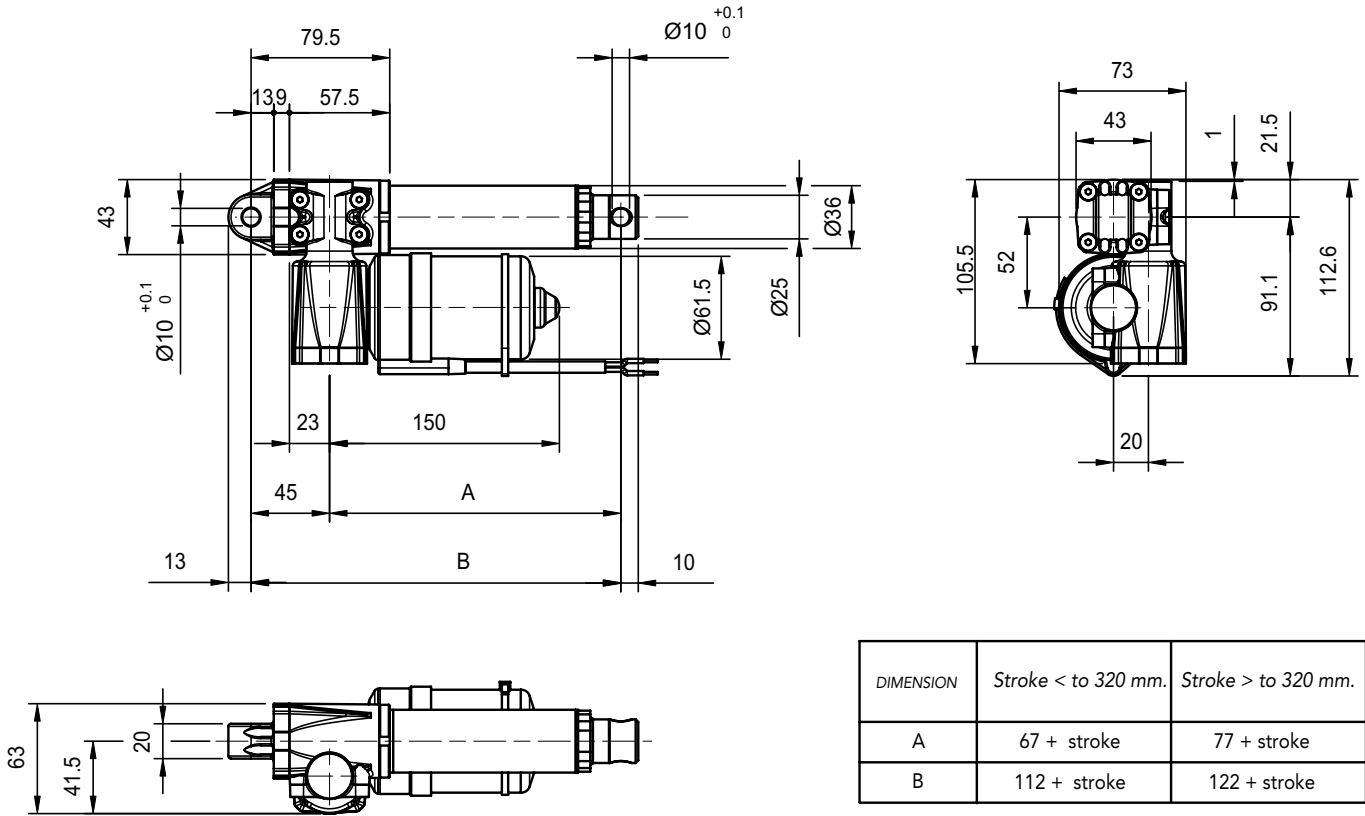

VERSION WITH LIMITSWITCHES

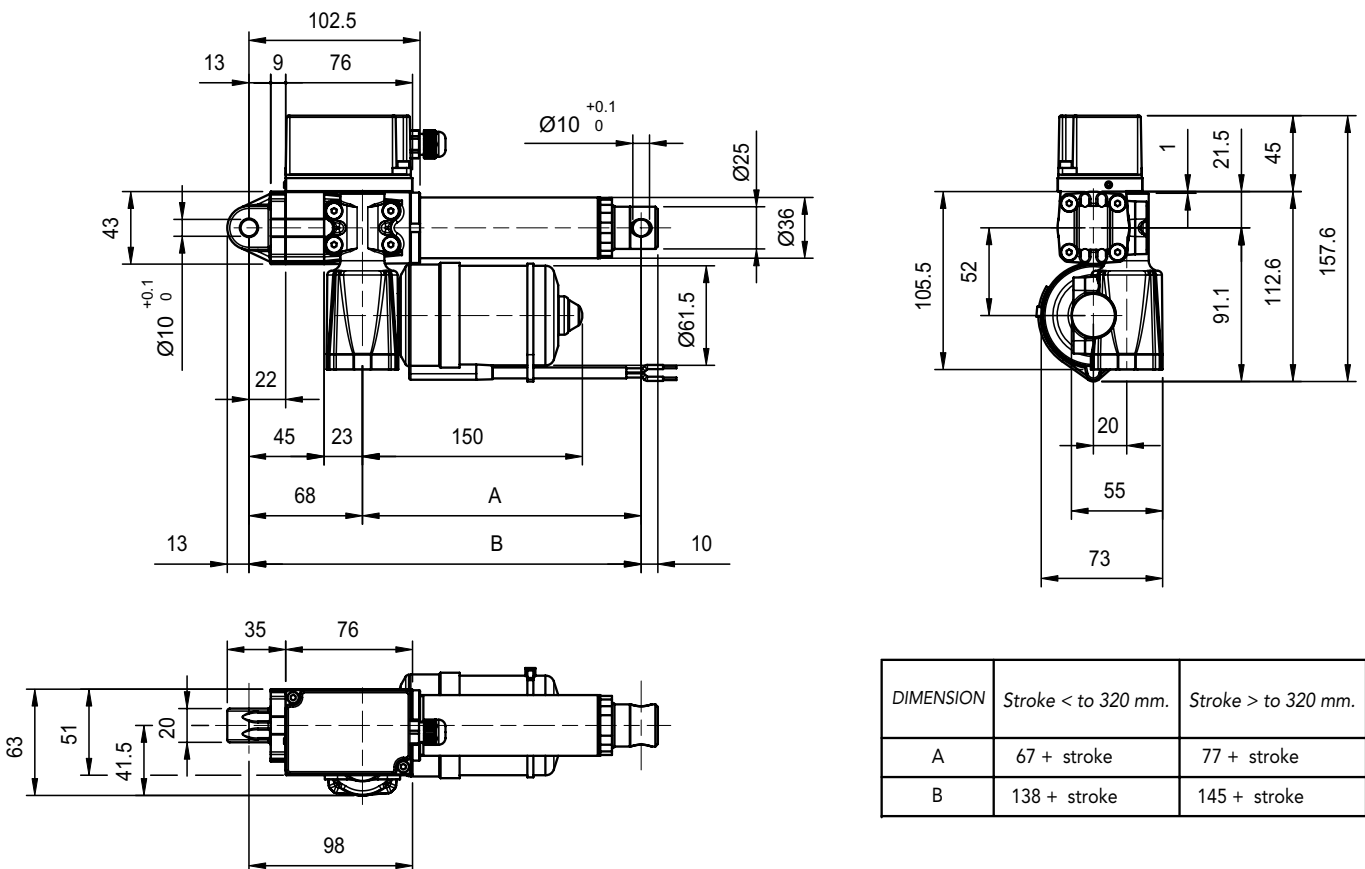

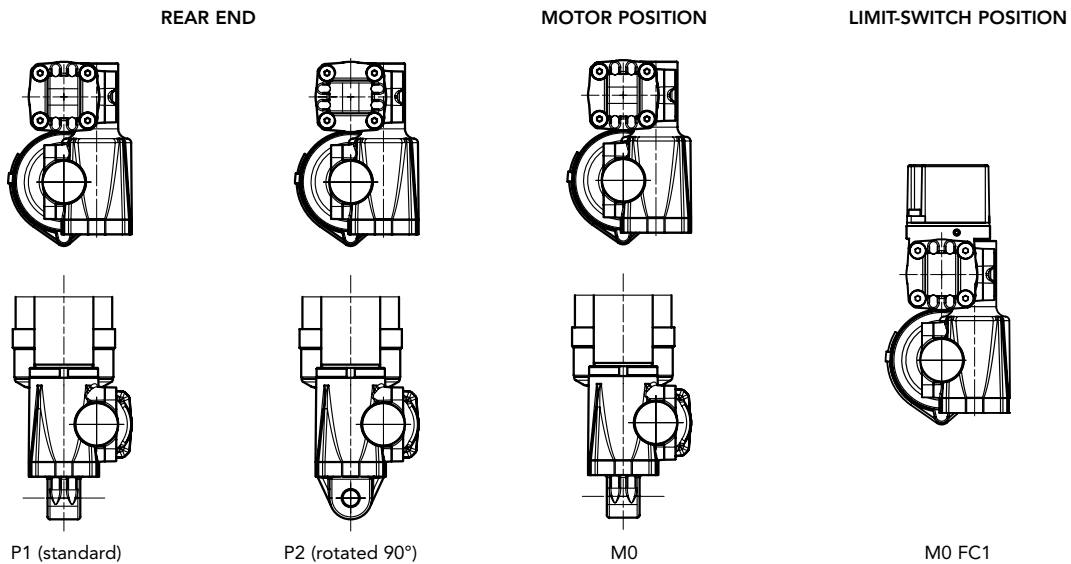

STROKE SETUP

Useful tips for handling stroke and avoid run-on-block collision.

- When stroke is more than 350 mm, add 50 mm extra-stroke as guidance, and put corresponding value in ordering-key.
- **WARNING SPEED-TIMING ALONG STROKELENGTH:** ramps are extremely important when speed is >30 mm/s!!! Inverter or PWM drive recommended!
- The more speed raises the more extra stroke has to raise too.

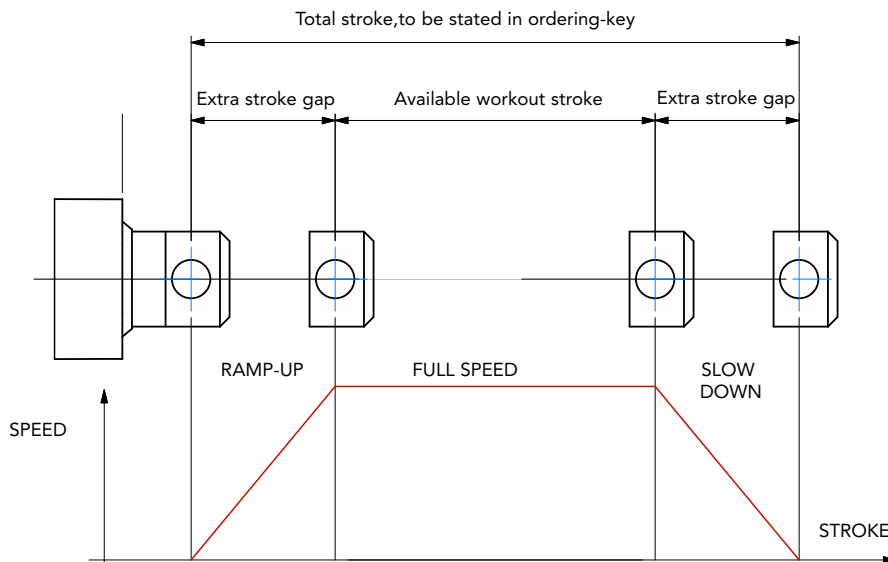

BUCKLING

When stroke is longer than 500mm, BUCKLING can be a risk: please check mounting with our offices and/or see usermanuals.

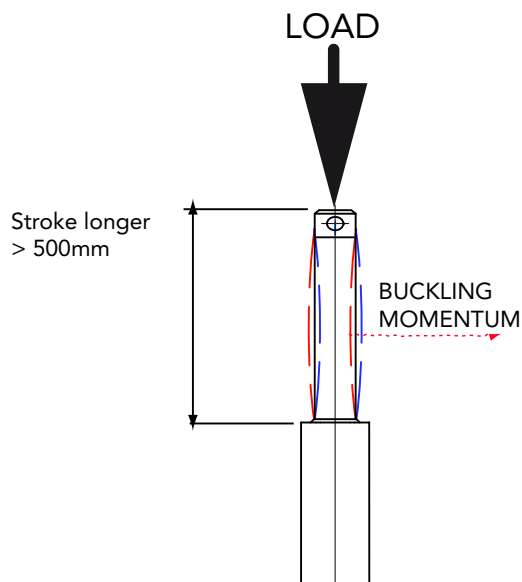

IMPORTANT:

Long strokes, even if load is low, can generate significant buckling momentums, as sketch shows. This happens when actuator is in its all-opened position: that's the reason why we recommend 100 mm extra-stroke. Pushtube will have this 100 mm-portion always inside the overtube, improving guidance against buckling.

For more information on this, contact our office.

ALI2-P/0250/M01/24/M0/E01/2FC1/POT01A/FC1/P1/A1/

MODEL	ALI2-P	ALI2-P-F	ALI2-P-FCM
STROKE (mm)	es. 250 mm = 0250		
VERSION	M01 / M03 / M04 / M05 / M07 / M09 M00 = Not standard speed		
MOTOR	12 = 12 Vdc	24 = 24 Vdc	
MOTOR POSITION	M0		
LIMIT SWITCHES	2FC1	None: Leave blank	
POTENTIOMETER	POT01A (1Kohm)	POT10A (10Kohm)	None: Leave blank
ENCODER	Options pg.76	None: Leave blank	
LIMIT SWITCHES POSITION	FC1	None: Leave blank	
REAR END	P1 = Eyelet (standard)	P2 = Eyelet (90°)	
FRONT END	A1 = Eyelet (standard)	A4 = Rod end	A3 = Yoke + Clip A7 = M10 male

NOTE: COMPLETE THE ORDERING KEY ADDING THE OPTIONS YOU CAN FIND IN THE "ACCESSORIES AND OPTIONS" SECTION

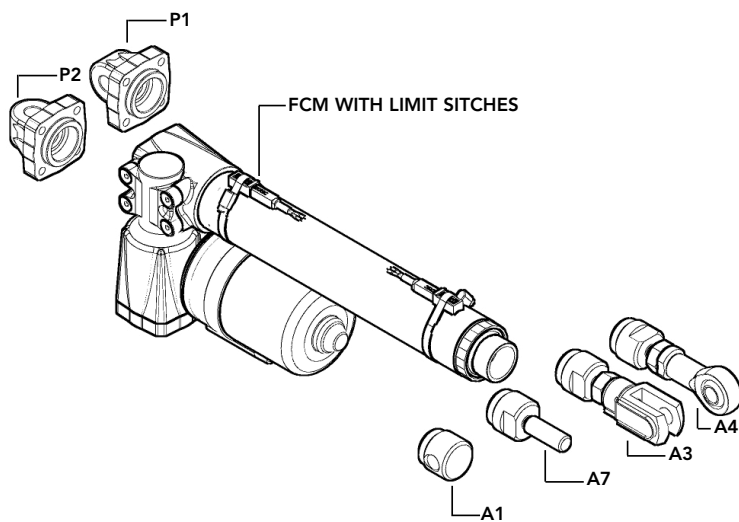

Note: "B" dimension changes according to model

ALI2-P= See pictures
 ALI2-P stroke > 320 mm = + 10 mm
 ALI2-PF = + 23 mm
 ALI2-PF stroke > 320 mm = +33
 ALI2-P-FCM = + 33 mm
 ALI2-P-FCM stroke > 320 mm = +43 mm
 ALI2-P with safety nut "G" = + 30 mm
 ALI2-P with bellows = + 20mm

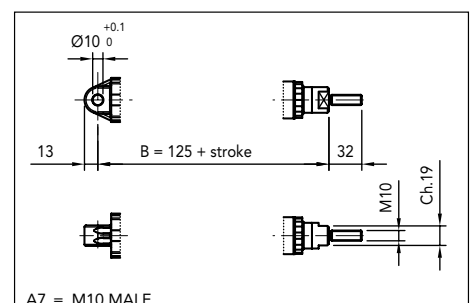
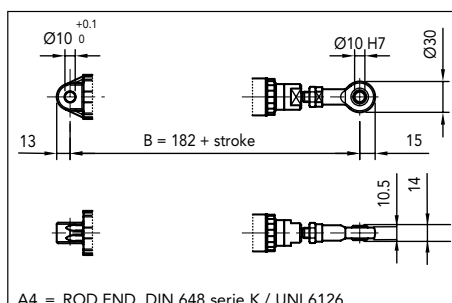
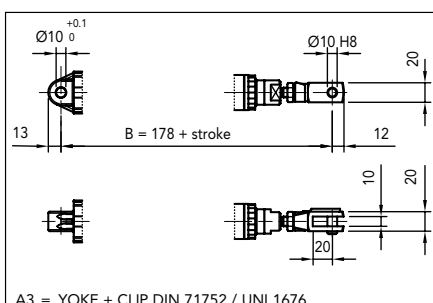

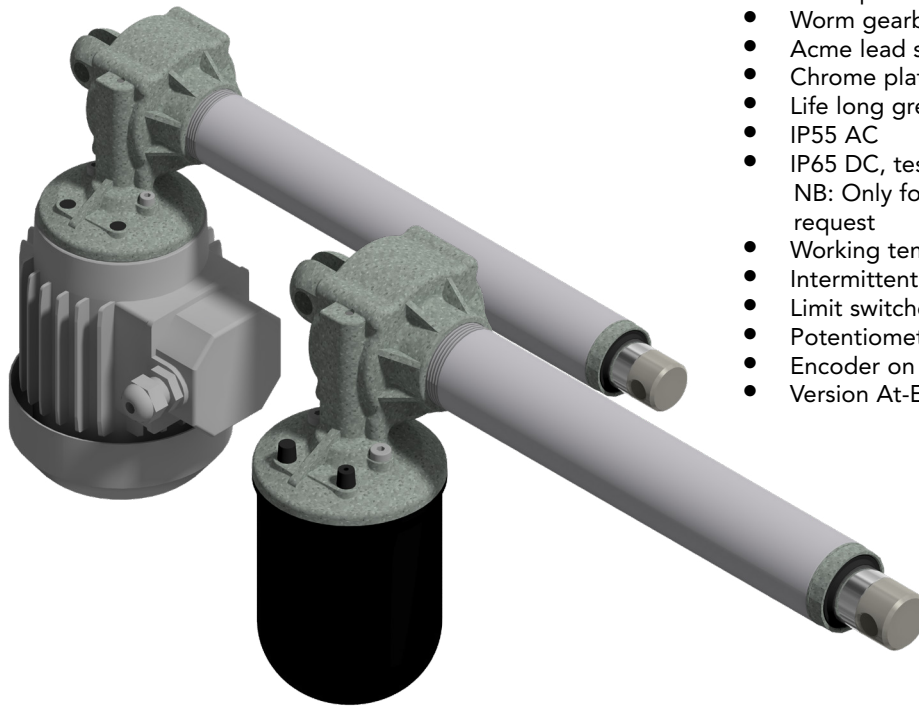

- Permanent magnet DC motor 12-24 V
- Three phase or single phase AC motor
- Worm gearbox
- Acme lead screw or ballscrew (VRS)
- Chrome plated steel push rod
- Life long grease lubricated
- IP55 AC
- IP65 DC, tested according to rule CEI EN 60529
NB: Only for brake motors Standard IP54, IP65 on request
- Working temperature range -10°C +60°C
- Intermittent duty S3 30% (5 min) a +30°C, only for AC
- Limit switches on request
- Potentiometer on request
- Encoder on request
- Version At-Ex II 3 D T4 (AC motor) on request

ALI3 (Vac 3-phase)				
Fmax (N)	Speed (mm/s)	Version	Motor size	Motor power (KW)
2600	20	M01	IEC56	0.09 2 poles
2800	14	M02	IEC56	0.09 2 poles
4800	7	M03	IEC56	0.09 2 poles
5000	5	M04	IEC56	0.09 2 poles
5000	2,5	M05	IEC56	0.09 2 poles

ALI3 VRS (ballscrew) (Vac 3-phase)				
Fmax (N)	Speed (mm/s)	Version	Motor size	Motor power (KW)
5000	9	M01	IEC56	0.09 2 poles
5000	3,5	M02	IEC56	0.09 2 poles

ALI3 (Vdc)						
Fmax (N)	Speed (mm/s)	Version	Motor size	Motor speed (rpm)	Max Current for F max(A) 24Vdc	Fs % base 5 min.
3600 *	35	M01	59	4900	15	10
3600	25	M02	59	4900	12	10
6000	12	M03	59	4900	14	10
6000	9	M04	59	4900	9,5	10
6000	5	M05	59	4900	7	20

With single-phase motors type M (see motor choice guideline in paragraph ACCESSORIES) performances are 20% lower than the three-phase motor.

For the DC models its is possible to add an IP20 break.

* When speed is more than 30 mm/s and/or strokes longer than 350mm, check STROKE SETUP section.

** For 12 Vdc power supply currents are doubled and loads are 20% lower.

→ The brakemotor is strongly recommended

BEFORE OPERATING ACTUATOR MAKE SURE YOU READ AND UNDERSTOOD BASIC OPERATIONAL INSTRUCTIONS SHOWN ON USERMANUALS, AVAILABLE FROM WEBSITE.

THIS DOCUMENT DISPLAYS MOST TYPICAL STANDARD FEATURES AND SETUPS: CONTACT OUR OFFICES FOR MORE. ACTUATOR SHALL NOT COME TO MECHANICAL STROKE-END, TO AVOID FAILURES. CONSIDER MECVEL'S LIMITSWITCHES (MODEL ALI3-F or ALI3-FCM) OR PUT THEM ON MACHINE/FRAME.



MecVel reserves the right to change products information and/or features without notice; all data contained in this catalogue are purely indicative and not binding for the company.

VERSION WITHOUT LIMITSWITCHES

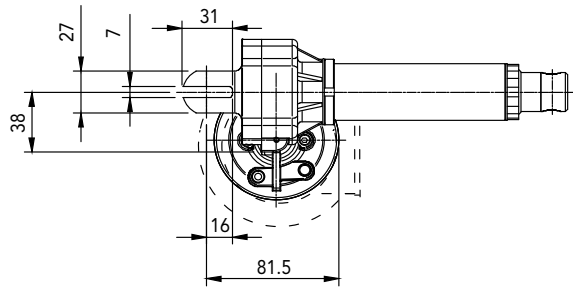
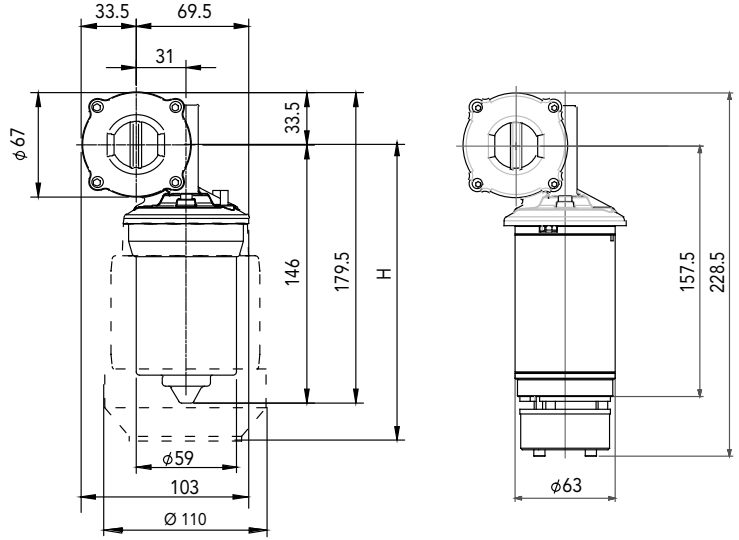
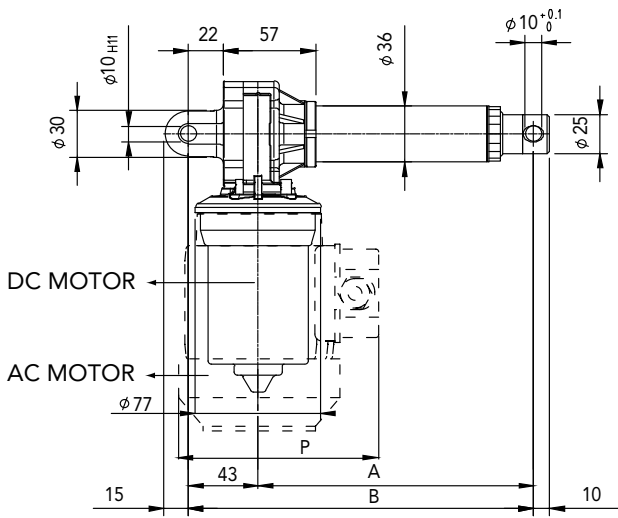

AC MOTOR DIMENSIONS				
SIZE	TYPE	H	Ø	P
56	Standard	232	110	150
	Brakemotor	276		

DIMENSION	Stroke < 320 mm	Stroke > 320 mm
A	69 + stroke	79 + stroke
B	112 + stroke	122 + stroke

VERSION WITH LIMITSWITCHES

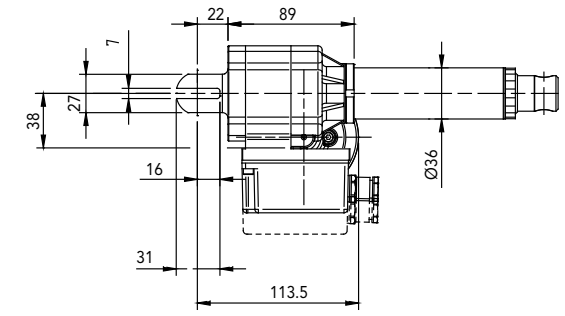
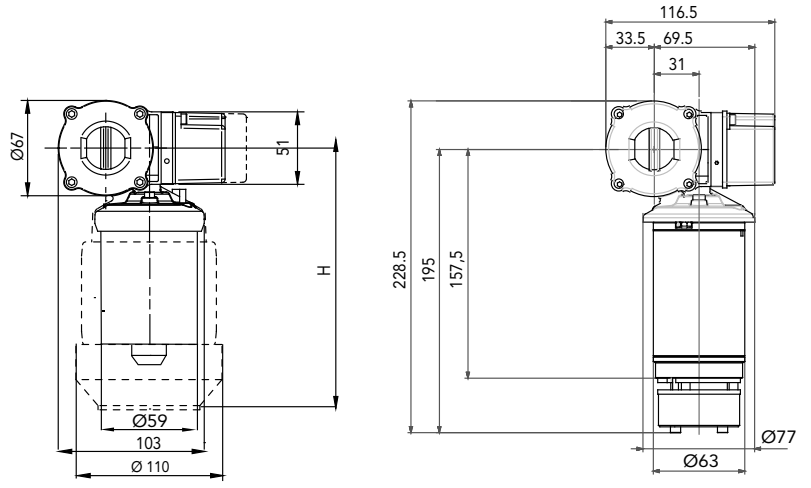
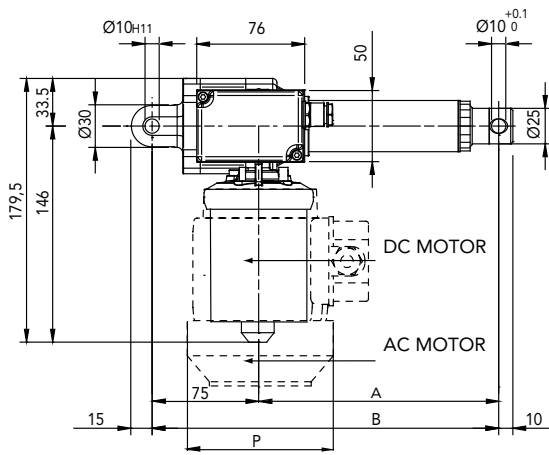

AC MOTOR DIMENSIONS				
SIZE	TYPE	H	Ø	P
56	Standard	232	110	150
	Brakemotor	276		

DIMENSION	Stroke < 320 mm	Stroke > 320 mm
A	69 + stroke	79 + stroke
B	144 + stroke	154 + stroke

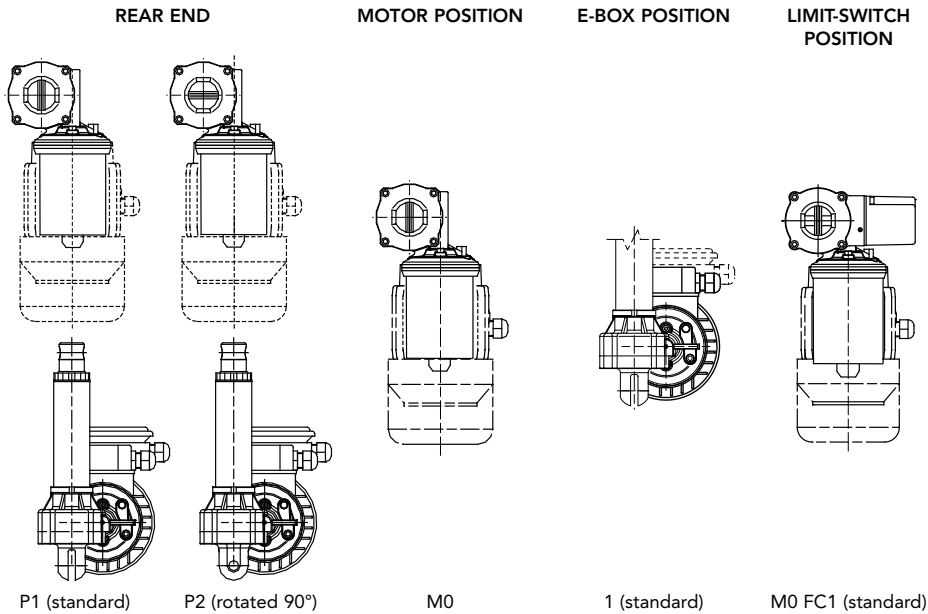

STROKE SETUP

Useful tips for handling stroke and avoid run-on-block collision.

- When stroke is more than 350 mm, add 50 mm extra-stroke as guidance, and put corresponding value in ordering-key.
- **WARNING SPEED-TIMING ALONG STROKELENGTH:** ramps are extremely important when speed is >30 mm/s! Inverter or PWM drive recommended!
- The more speed raises the more extra stroke has to raise too.

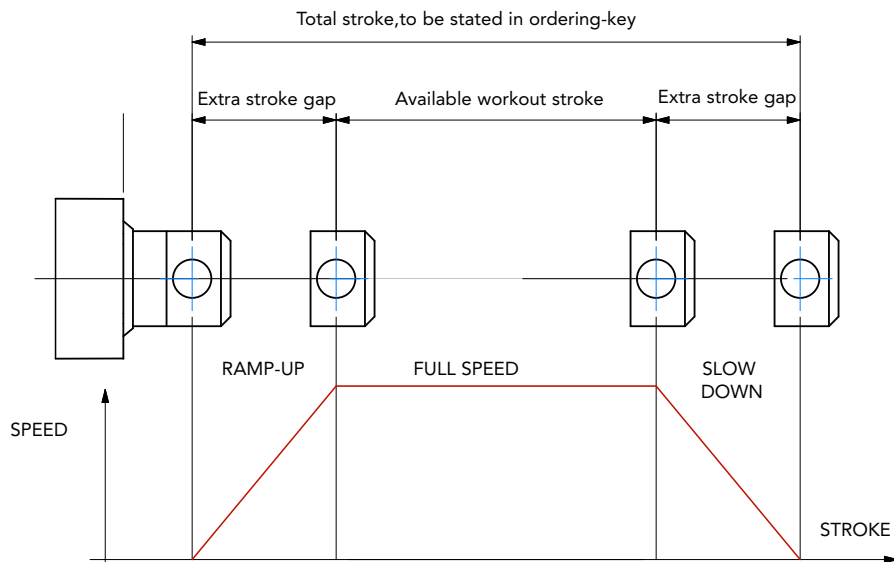

BUCKLING

When stroke is longer than 500mm, BUCKLING can be a risk: please check mounting with our offices and/or see usermanuals.

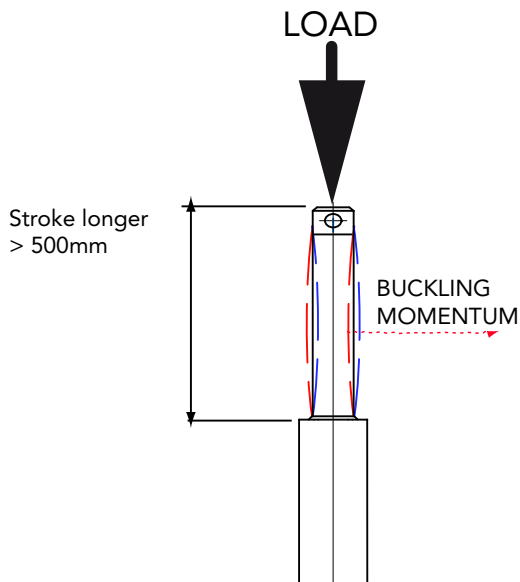

IMPORTANT:

Long strokes, even if load is low, can generate significant buckling momentums, as sketch slows. This happens when actuator is in its all-opened position: that's the reason why we recommend 100 mm extra-stroke. Pushtube will have this 100 mm-portion always inside the overtube, improving guidance against buckling.

For more information on this, contact our office.

ALI3/0250/M03/CA-400/50-T-56-2-0,09/AB/M0/1/E06/2FC1/POT01A/FC1/P1/A1/

MODEL _____
 ALI3 / ALI3-F / ALI3-VRS / ALI3-F-VRS / ALI3-FCM / ALI3-FCM-VRS
STROKE _____

es. 250 mm = 0250

VERSION _____
 M01 / M02 / M03 / M04 / M05 (DC)
 M01 / M02 / M03 / M04 / M05 (AC)
 M00 = Not standard speed

MOTOR _____
 AC: version, voltage, type, size, n°pole, power
 CC: version, voltage, size, Rpm

AC MOTOR OPTIONS _____
 With DC motor, dont consider the following lines
 Protection Degree: IP65, for selfbrake motor IP54 standard
 Brake type: for brakemotors only (es. FECA)
 Options: Advise if needed (es. AB 2'shaft)

MOTOR POSITION _____
 M0 None: Leave blank

E-BOX POSITION _____
 1

ENCODER _____
 Options pg.76 None: Leave blank

LIMIT SWITCHES _____
 2FC1 None: Leave blank

POTENTIOMETER _____
 POT01A (1Kohm) POT10A (10Kohm) None: Leave blank

LIMIT SWITCHES POSITION _____
 FC1 None: Leave blank

REAR END _____
 P1 = Eyelet (standard) P2 = Eyelet (90°)

FRONT END _____
 A1 = Eyelet (standard) A4 = Rod end A3 = Yoke + Clip A7 = M10 male

NOTE: COMPLETE THE ORDERING KEY ADDING THE OPTIONS YOU CAN FIND IN THE "ACCESSORIES AND OPTIONS" SECTION

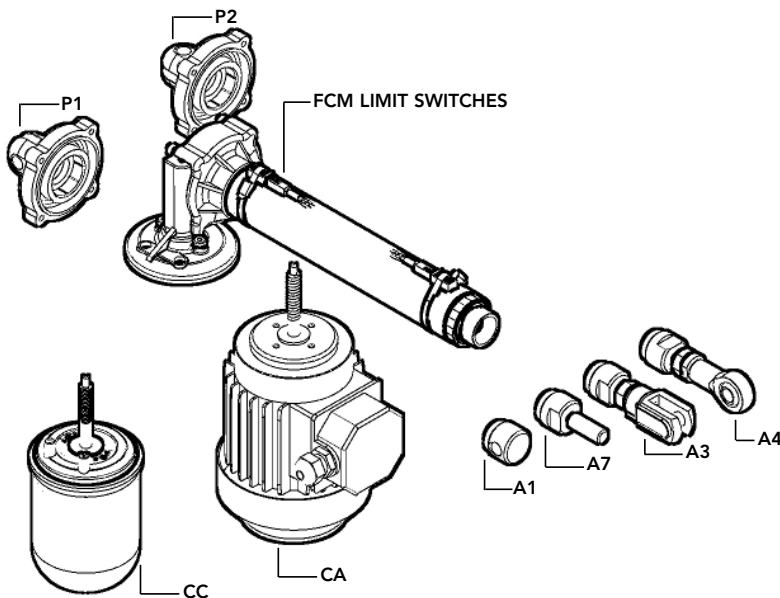

Note: "B" dimension changes according to model

- ALI3 = See pictures
- ALI3 stroke > 320 mm = + 10 mm
- ALI3-FCM = + 34 mm
- ALI3-FCM stroke > 320 mm = +44
- ALI3-F = + 23 mm
- ALI3-F stroke > 320 mm = + 33 mm
- With safety nut "G" = + 30 mm
- ALI3-VRS = + 40 mm
- ALI3-F-VRS = + 63 mm
- Bellows + 20mm

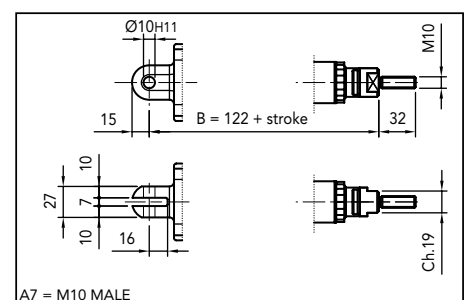
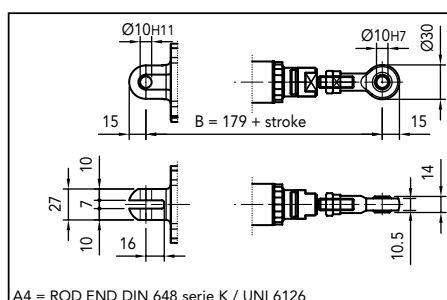
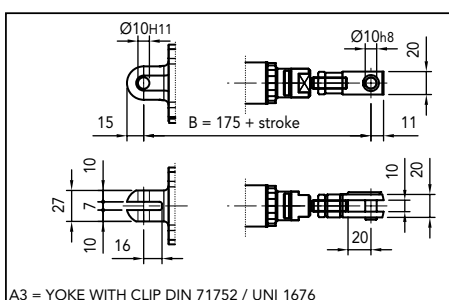

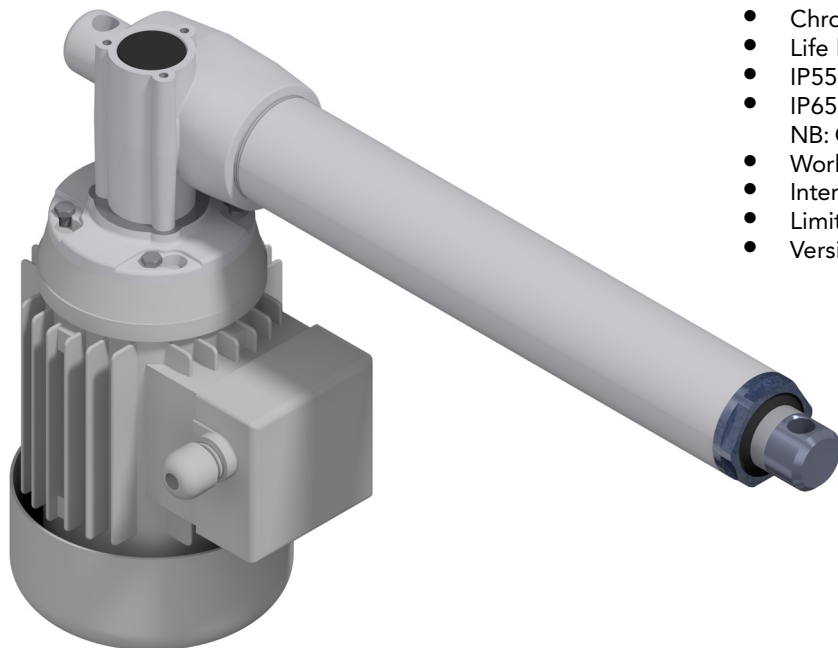

- Permanent magnet DC motor 24 V
- Three phase and single phase AC motor
- Worm gearbox
- Acme lead screw or ballscrew (VRS)
- Chrome plated steel push rod
- Life long grease lubricated
- IP55 CC
- IP65 DC, tested according to rule CEI EN 60529
- NB: Only for brake motors Standard IP54, IP65 on request
- Working temperature range -10°C +60°C
- Intermittent duty S3 30% (5 min) a +30°C for AC motor
- Limit switches, potentiometer and encoder on request
- Version At-Ex II 3 D T4 (AC motor) on request

ALI4 (Vac triphase)				
Fmax (N)	Speed (mm/s)	Version	Motor size	Motor power (KW)
2100 *	93	M01	IEC71	0.55 2 poles
3900 *	47	M02	IEC71	0.55 2 poles
5300	23	M03	IEC63	0.37 4 poles
8600	9	M04	IEC63	0.22 4 poles
9400	6	M05	IEC63	0.22 4 poles
10000	3	M06	IEC63	0.13 4 poles

ALI4 (Vdc)						
Fmax (N)	Speed (mm/s)	Version	Motor size	Motor speed (rpm)	Max Current for F max(A) 24Vdc	Fs % base 5 min.
600*	100	M20	77	3000	9	20
1100*	50	M21	77	3000	11	20
2800	20	M22	77	3000	12	20
4100	13	M23	77	3000	13	10
6800	7	M24	77	3000	12	20

ALI4 VRS (Vac triphase)				
Fmax (N)	Speed (mm/s)	Version	Motor size	Motor power (KW)
2500 *	58	M08	IEC63	0.25 2 poles
3100	29	M09	IEC63	0.18 4 poles
3400	23	M10	IEC56	0.13 2 poles
5000	15	M11	IEC56	0.13 2 poles
6000	7	M12	IEC56	0.09 4 poles
7500	4	M13	IEC56	0.09 4 poles

ALI4 VRS (Vdc)						
Fmax (N)	Speed (mm/s)	Version	Motor size	Motor speed (rpm)	Max Current for F max(A) 24Vdc	Fs % base 5 min.
2400*	63	M26	77	3000	11,5	20
3400	25	M27	77	3000	8	20
3900	16	M28	77	3000	7	30
6800	8	M29	77	3000	7	30
7500	5	M30	77	3000	6	30

* When speed is more than 30 mm/s and/or strokes longer than 350mm, check STROKE SETUP section.

With single-phase motors type M (see motor choice guideline in paragraph ACCESSORIES) performances are 20% lower than the three-phase motor.

→ The brakemotor is strongly recommended

THIS DOCUMENT DISPLAYS MOST TYPICAL STANDARD FEATURES AND SETUPS: CONTACT OUR OFFICES FOR MORE. ACTUATOR SHALL NOT COME TO MECHANICAL STROKE-END, TO AVOID FAILURES.

BEFORE OPERATING ACTUATOR MAKE SURE YOU READ AND UNDERSTOOD BASIC OPERATIONAL INSTRUCTIONS SHOWN ON USERMANUALS, AVAILABLE FROM WEBSITE. CONSIDER MECVEL's LIMITSWITCHES (MODEL ALI4-F or ALI4-FCM) OR PUT THEM ON MACHINE/FRAME

 MecVel reserves the right to change products information and/or features without notice; all data contained in this catalogue are purely indicative and not binding for the company.

VERSION WITHOUT LIMITSWITCHES

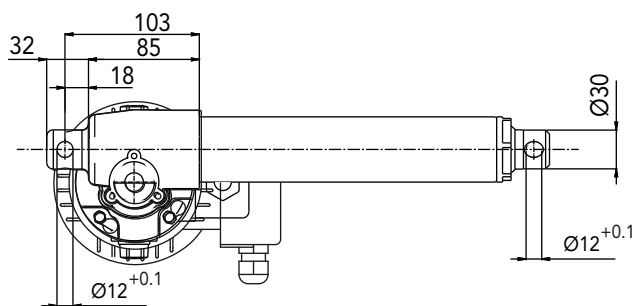
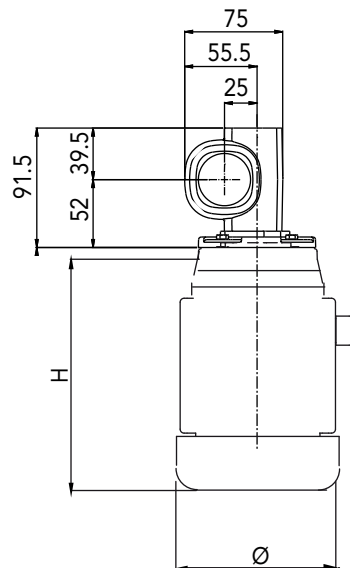
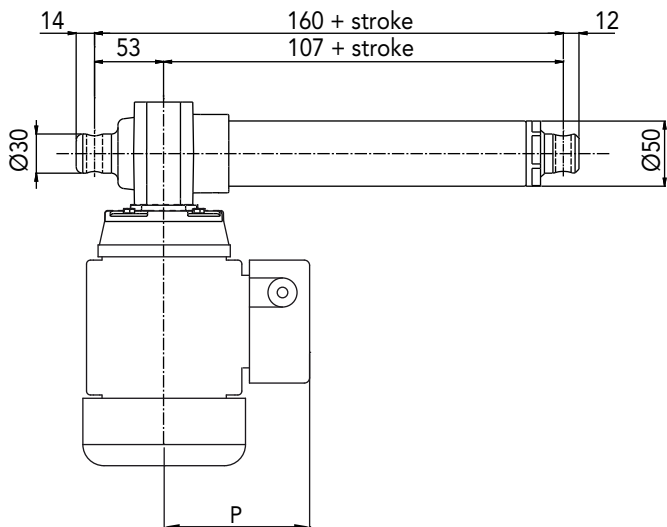

A.C. MOTORS DIMENSIONS				
GR. / SIZE	TYPE	H	Ø	P
56	Standard	168	116	108
	Brake motors	200		
63	Standard	190	129	110
	Brake motors	235		
71	Standard	220	146	121
	Brake motors	267		

VERSION WITH LIMITSWITCHES

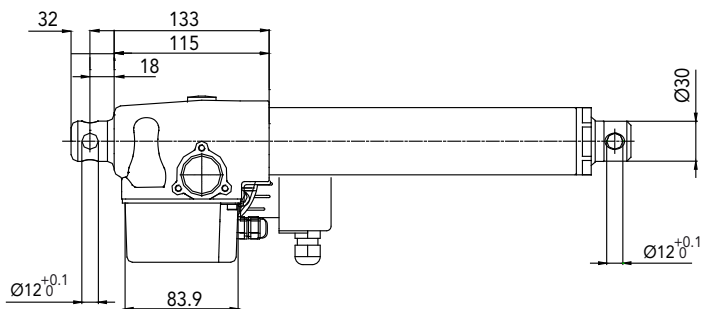
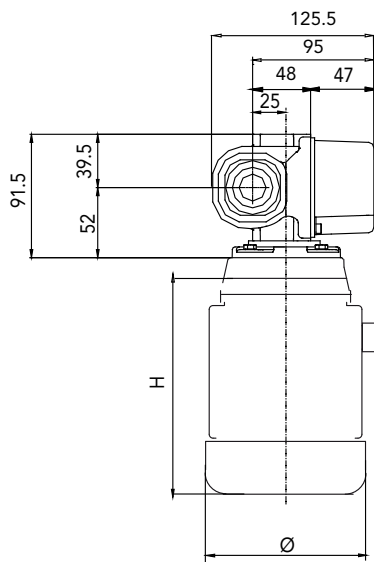
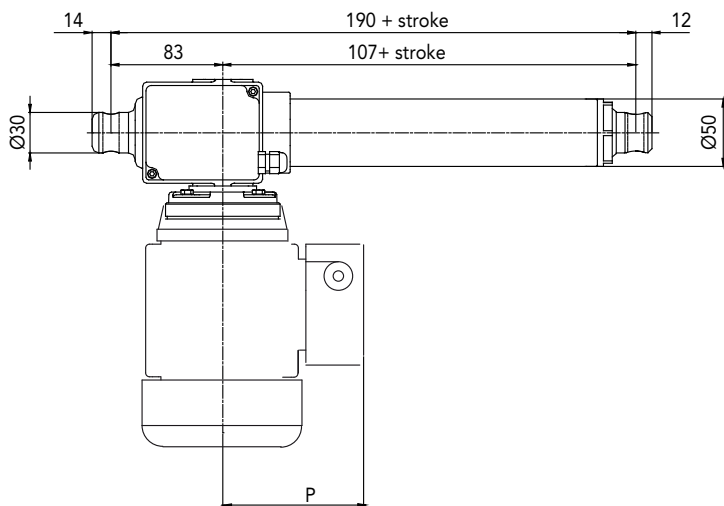

A.C. MOTORS DIMENSIONS				
SIZE	TYPE	H	Ø	P
56	Standard	168	116	108
	Brake motors	200		
63	Standard	190	129	110
	Brake motors	235		
71	Standard	220	146	121
	Brake motors	267		

REAR END

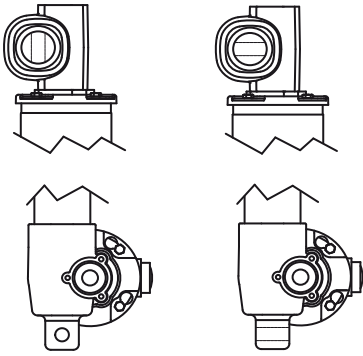

P1 (standard)

P2 (rotated 90°)

MOTOR POSITION

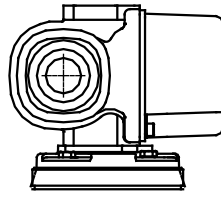

M0

E-BOX POSITION

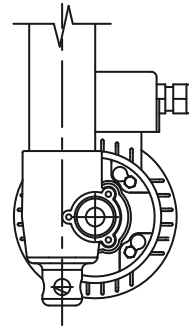

1 (standard)

LIMIT-SWITCH POSITION

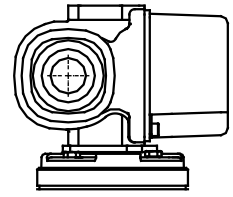

M0 FC1 (standard)

STROKE SETUP

Useful tips for handling stroke and avoid run-on-block collision.

- When stroke is more than 350 mm, add 50 mm extra-stroke as guidance, and put corresponding value in ordering-key.
- **WARNING SPEED-TIMING ALONG STROKELENGTH:** ramps are extremely important when speed is >30 mm/s! Inverter or PWM drive recommended!
- The more speed raises the more extra stroke has to raise too.

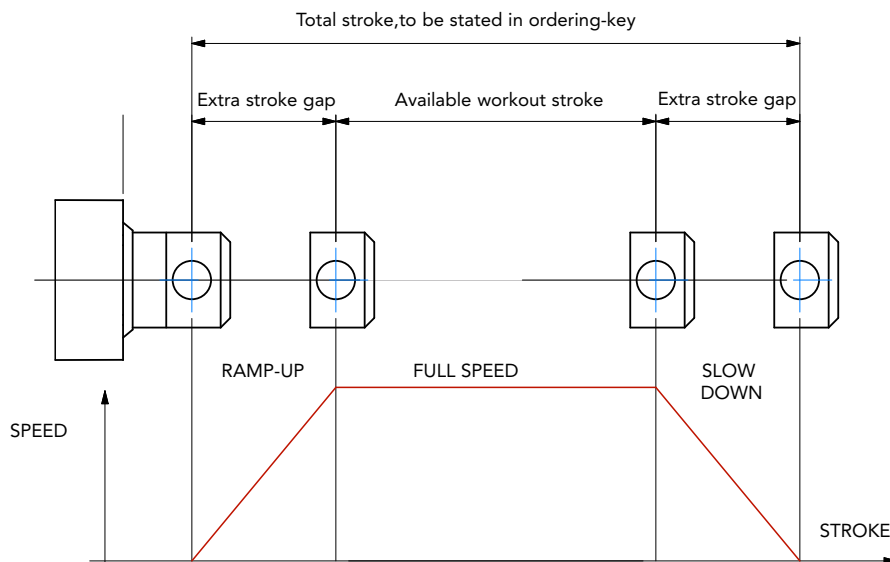

BUCKLING

When stroke is longer than 500mm, BUCKLING can be a risk: please check mounting with our offices and/or see usermanuals.

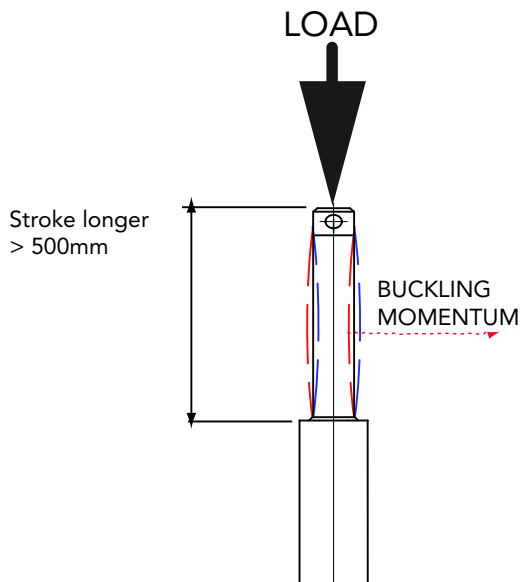

IMPORTANT:

Long strokes, even if load is low, can generate significant buckling momentums, as sketch slows. This happens when actuator is in its all-opened position: that's the reason why we recommend 100 mm extra-stroke. Pushtube will have this 100 mm-portion always inside the overtube, improving guidance against buckling.

For more information on this, contact our office.

ALI4/0250/M06/CA-400/50-T-63-4-0,13/AB/M0/1/E06/2FC1/POT01A/FC1/P1/A1/

MODEL _____
 ALI4 / ALI4-F / ALI4-FCM / ALI4-FCI / ALI4-VRS / ALI4-VRS-F / ALI4-VRS-FCM / ALI4-VRS-FCI

STROKE _____
 es. 250 mm = 0250

VERSION _____
 M01 / M02 / M03 / M04 / M06 / M08 / M09 / M10 / M11 / M12 / M13
 M00 Not standard speed
 Flanged version: indicate reduction ratio and screw pitch

MOTOR _____
 AC: version, voltage, type, size, n°pole, power
 With motorflange only put 0
 With special motorflange put: PD

AC MOTOR OPTIONS _____
 Motorflange: for motorflange version only advise size - i.e.for IEC56 B14 put 56B14
 Protection Degree: IP65, for selfbrake motor IP54 standard
 Brake type: for brakemotors only (es. FECA)
 Options: Advise if needed (es. AB 2'shaft)

MOTOR POSITION _____
 M0 None: Leave blank

LIMIT SWITCHES _____
 2FC1 None: Leave blank

LIMIT SWITCHES POSITION _____
 FC1 None: Leave blank

E-BOX POSITION _____
 1 No Motor: Leave blank

ENCODER _____
 Options pg.76 None: Leave blank

POTENTIOMETER _____
 POT01A (1Kohm) POT10A (10Kohm) None: Leave blank

REAR END _____
 P1 = Eyelet (standard) P2 = Eyelet (90°)

FRONT END _____
 A1 = Eyelet (standard) A3 = Yoke + Clip A4 = Rod end A7 = M12 male

NOTE: COMPLETE THE ORDERING KEY ADDING THE OPTIONS YOU CAN FIND IN THE "ACCESSORIES AND OPTIONS" SECTION _____

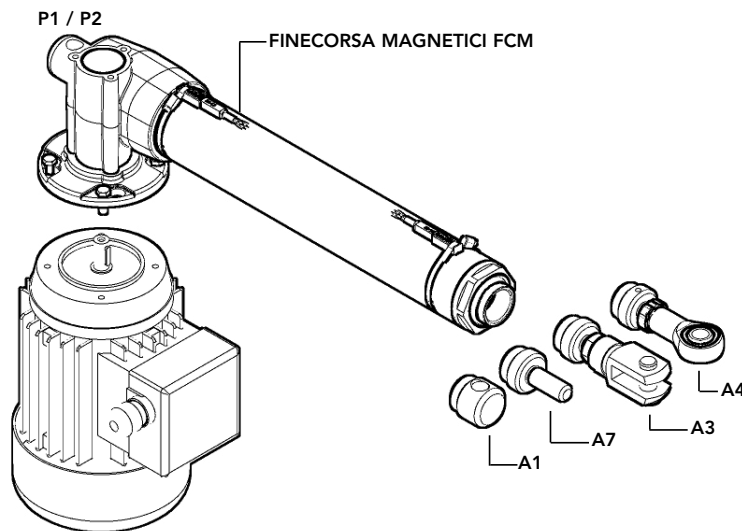

Note: "B" dimension variations depending on model

- ALI4 = see pictures
- ALI4-F = + 30 mm
- ALI4-FCM = + 42,5 mm
- ALI4-FCI = + 42,5 mm
- with safety nut "G" = + 30 mm
- ALI4-VRS (versione 16x5) = + 25 mm
- ALI4-VRS-F (versione 16x5) = + 55 mm
- ALI4-VRS-FCM (versione 16x5) = + 53 mm
- ALI4-VRS-FCI (versione 16x5) = + 53 mm
- L = + 15 mm
- Bellows = + 15 mm (excluding FCM and FCI version)

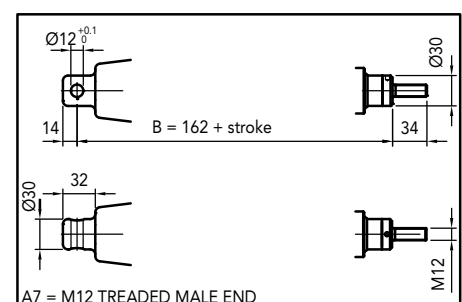
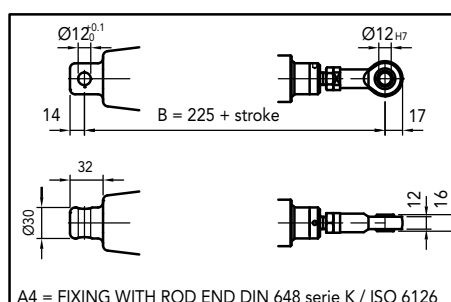
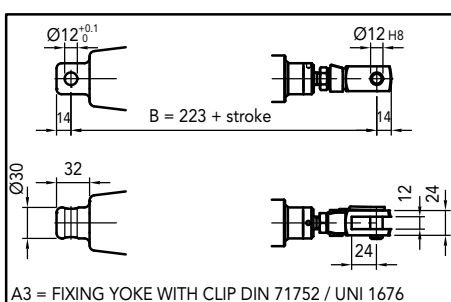

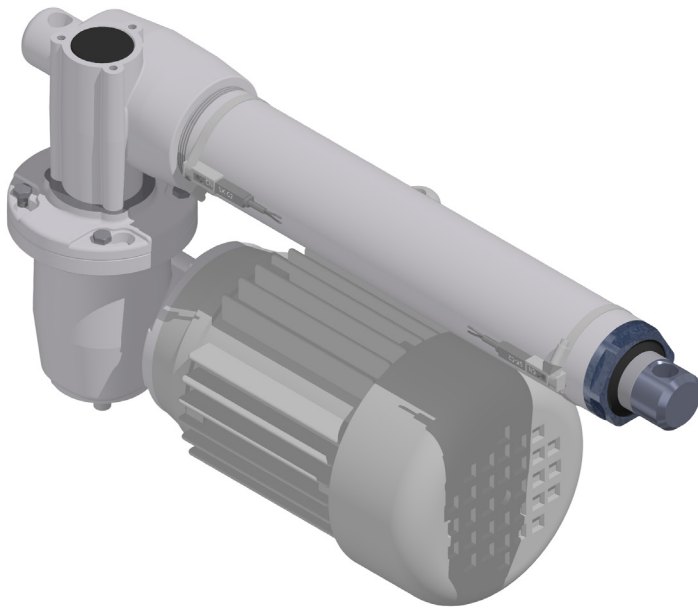

- Permanent magnet DC motor 24 V
- Three phase and single phase AC motor
- Worm gearbox
- Acme lead screw or ballscrew (VRS)
- Chrome plated steel push rod
- Permanent lubrication
- IP65 for DC versions
- IP55 for AC versions, tested according to rule CEI EN 60529. NB: Only for brake motors Standard IP54, IP65 on request
- Working temperature range -10°C +60°C
- Intermittent duty S3 30% (5 min) a +30°C for AC motor
- Limit switches, potentiometer and encoder on request
- Version At-Ex II 3 D T4 (AC motor) on request

ALI4-P (Vac triphase)				
Fmax (N)	Speed (mm/s)	Version	Motor size	Motor power (KW)
11000	12	M01	IEC71	0.55 2 poles
15000	6	M02	IEC63	0.37 4 poles

ALI4-P (Vdc)						
Fmax (N)	Speed (mm/s)	Version	Motor size	Motor speed (rpm)	Max Current for F max(A) 24Vdc	Fs % base 5 min.
1700*	48	M03	77	3000	11	20
2600	29	M04	77	3000	12	20
4500	14	M05	77	3000	11	20
6800	8	M06	77	3000	12	20
10000	5	M07	77	3000	14	10

* When speed is more than 30 mm/s and/or strokes longer than 350mm, check STROKE SETUP section.

With single-phase motors type M (see motor choice guideline in paragraph ACCESSORIES) performances are 20% lower than the three-phase motor.

→ The brakemotor is strongly recommended

THIS DOCUMENT DISPLAYS MOST TYPICAL STANDARD FEATURES AND SETUPS: CONTACT OUR OFFICES FOR MORE. ACTUATOR SHALL NOT COME TO MECHANICAL STROKE-END, TO AVOID FAILURES.

BEFORE OPERATING ACTUATOR MAKE SURE YOU READ AND UNDERSTOOD BASIC OPERATIONAL INSTRUCTIONS SHOWN ON USERMANUALS, AVAILABLE FROM WEBSITE. CONSIDER MECVEL's LIMITSWITCHES (MODEL ALI4-F or ALI4-FCM) OR PUT THEM ON MACHINE/FRAME



MecVel reserves the right to change products information and/or features without notice; all data contained in this catalogue are purely indicative and not binding for the company.

VERSION WITHOUT LIMITSWITCHES

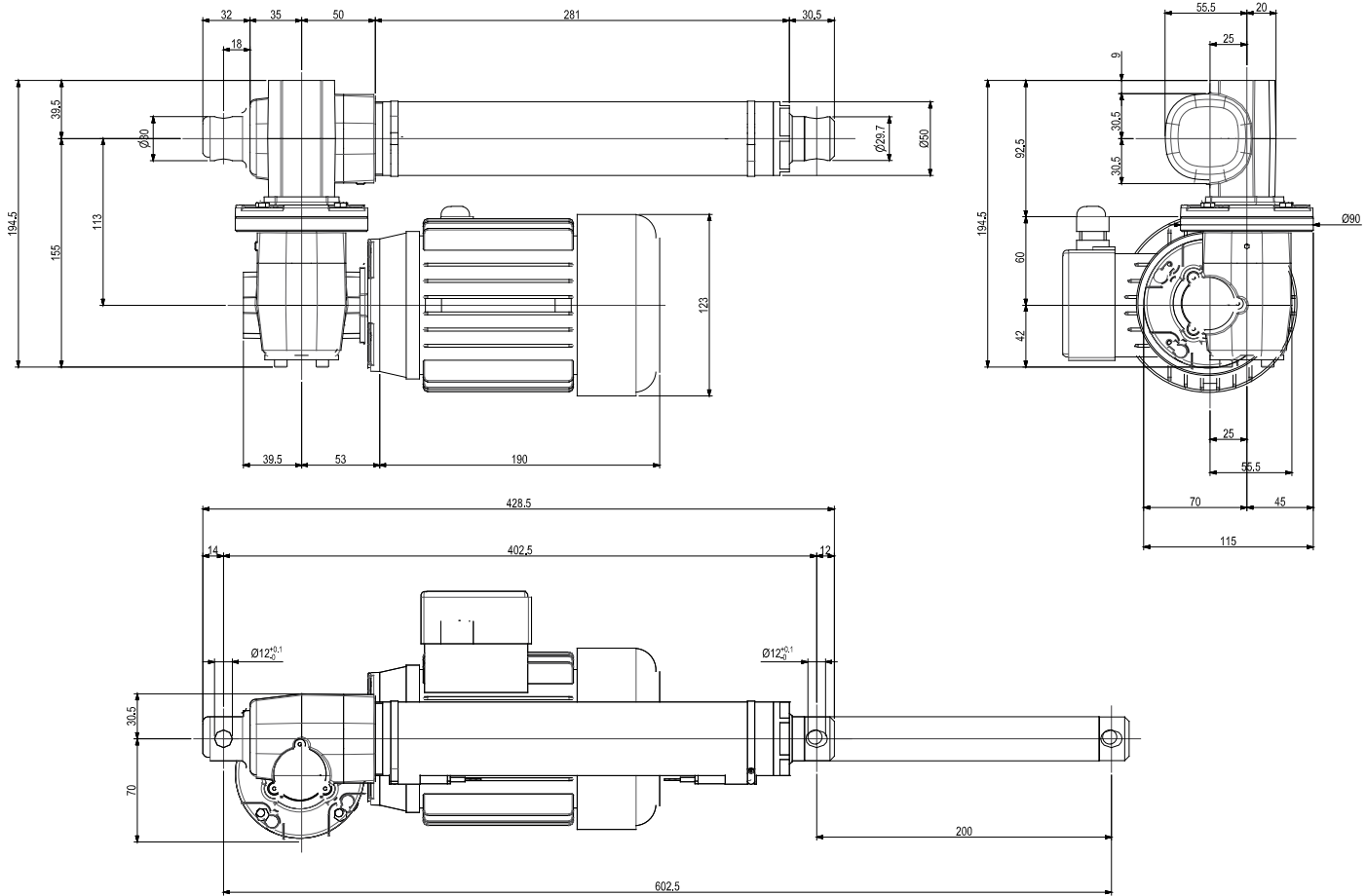

VERSION WITH LIMITSWITCHES

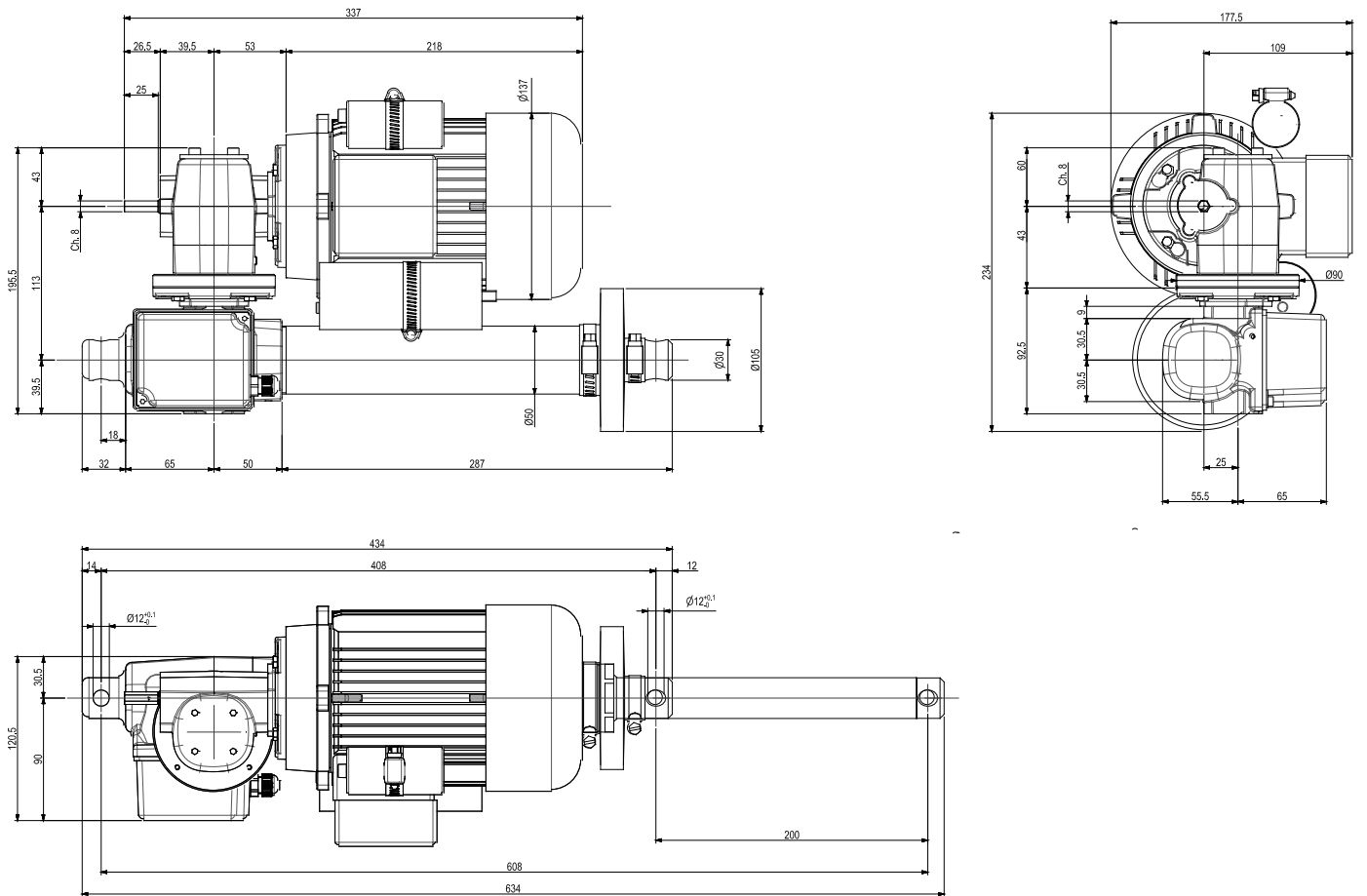

REAR END

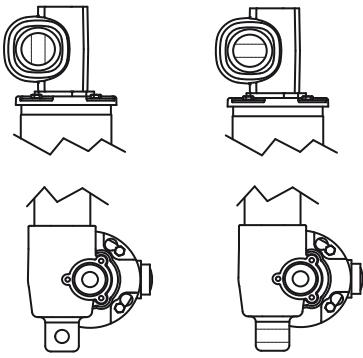

P1 (standard)

P2 (rotated 90°)

MOTOR POSITION

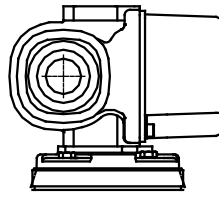

M0

E-BOX POSITION

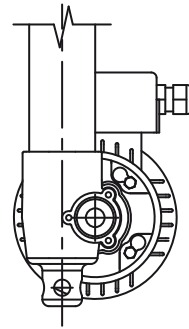

1 (standard)

LIMIT-SWITCH POSITION

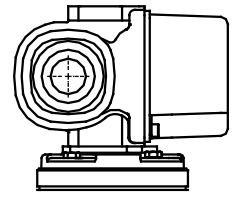

M0 FC1 (standard)

STROKE SETUP

Useful tips for handling stroke and avoid run-on-block collision.

- When stroke is more than 350 mm, add 50 mm extra-stroke as guidance, and put corresponding value in ordering-key.
- **WARNING SPEED-TIMING ALONG STROKELENGTH:** ramps are extremely important when speed is >30 mm/s!!! Inverter or PWM drive recommended!
- The more speed raises the more extra stroke has to raise too.

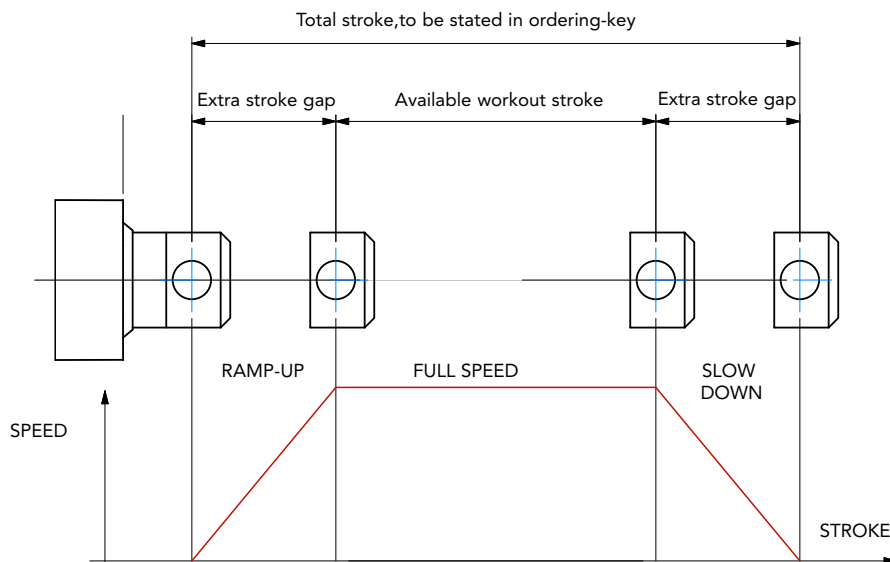

BUCKLING

When stroke is longer than 500mm, BUCKLING can be a risk: please check mounting with our offices and/or see usermanuals.

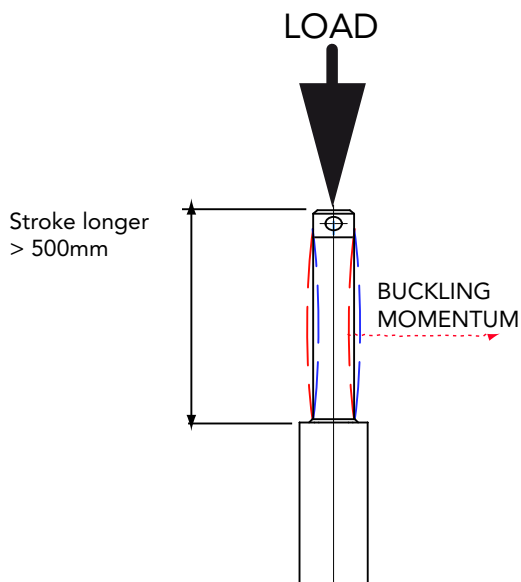

IMPORTANT:

Long strokes, even if load is low, can generate significant buckling momentums, as sketch slows. This happens when actuator is in its all-opened position: that's the reason why we recommend 100 mm extra-stroke. Pushtube will have this 100 mm-portion always inside the overtube, improving guidance against buckling.

For more information on this, contact our office.

ALI4-P/0250/M01/CA-400/50-T-71-2-0,55/AB/M0/1/E06/2FC1/POT01A/FC1/P1/A1/

MODEL _____
 ALI4-P / ALI4-P-F / ALI4-P-FCM / ALI4-P-FCI / ALI4-P-VRS / ALI4-P-VRS-F / ALI4-P-VRS-FCM / ALI4-P-VRS-FCI

STROKE _____
 es. 250 mm = 0250

VERSION _____
 M01 / M02 / M03 / M04 / M05 / M06 / M07
 M00 Not standard speed
 Flanged version: indicate reduction ratio and screw pitch

MOTOR _____
 AC: version, voltage, type, size, n°pole, power
 With motorflange only put 0
 With special motorflange put: PD

AC MOTOR OPTIONS _____
 Motorflange: for motorflange version only advise size - i.e.for IEC56 B14 put 56B14
 Protection Degree: IP65, for selfbrake motor IP54 standard
 Brake type: for brakemotors only (es. FECA)
 Options: Advise if needed (es. AB 2'shaft)

MOTOR POSITION _____
 M0 None: Leave blank

LIMIT SWITCHES _____
 2FC1 None: Leave blank

LIMIT SWITCHES POSITION _____
 FC1 None: Leave blank

E-BOX POSITION _____
 1 No Motor: Leave blank

ENCODER _____
 Options pg.76 None: Leave blank

POTENTIOMETER _____
 POT01A (1Kohm) POT10A (10Kohm) None: Leave blank

REAR END _____
 P1 = Eyelet (standard) P2 = Eyelet (90°)

FRONT END _____
 A1 = Eyelet (standard) A3 = Yoke + Clip A4 = Rod end A7 = M12 male

NOTE: COMPLETE THE ORDERING KEY ADDING THE OPTIONS YOU CAN FIND IN THE "ACCESSORIES AND OPTIONS" SECTION

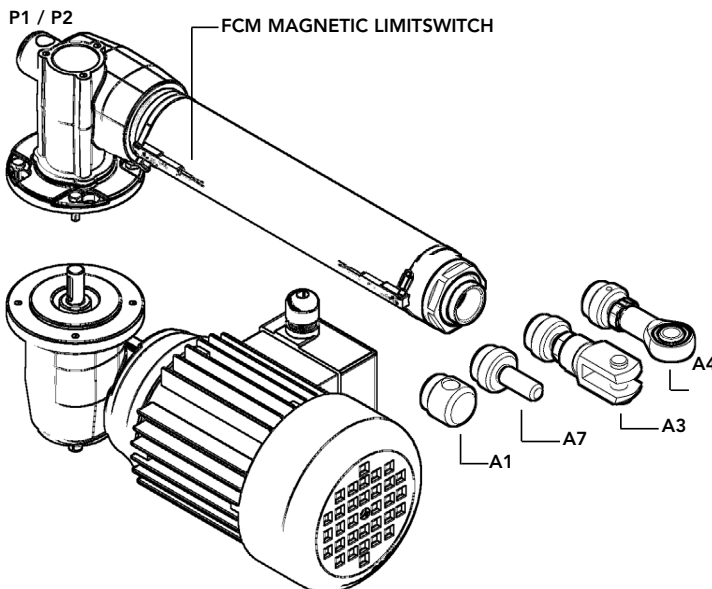

Note: "B" dimension changes according to model

- ALI4-P = See figure
- ALI4-P-F = +30 mm
- ALI4-P-FCM = +42,5 mm
- ALI4-P-FCI = +42,5 mm
- ALI4-P VRS = +25 mm
- ALI4-P-F VRS = +55 mm
- ALI4-P-FCM VRS = +53 mm
- ALI4-P-FCI VRS = +53 mm
- ALI4-P with antirotation device L = +15 mm
- ALI4-P with safety nut G = +30 mm
- ALI4-P with bellows boot B = +15 mm (not compatible with FCM e FCI versions)

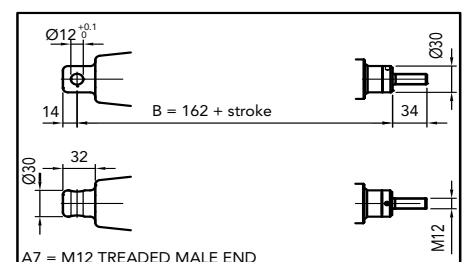
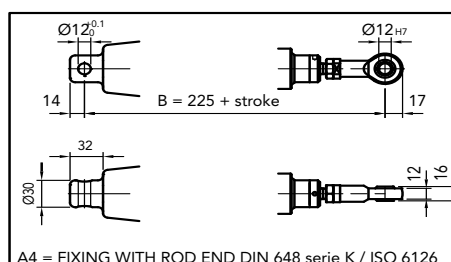
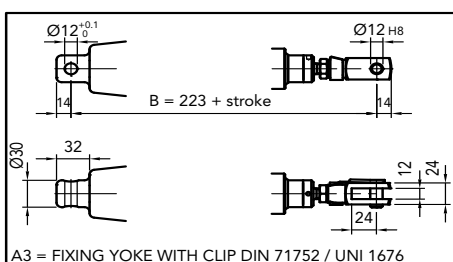

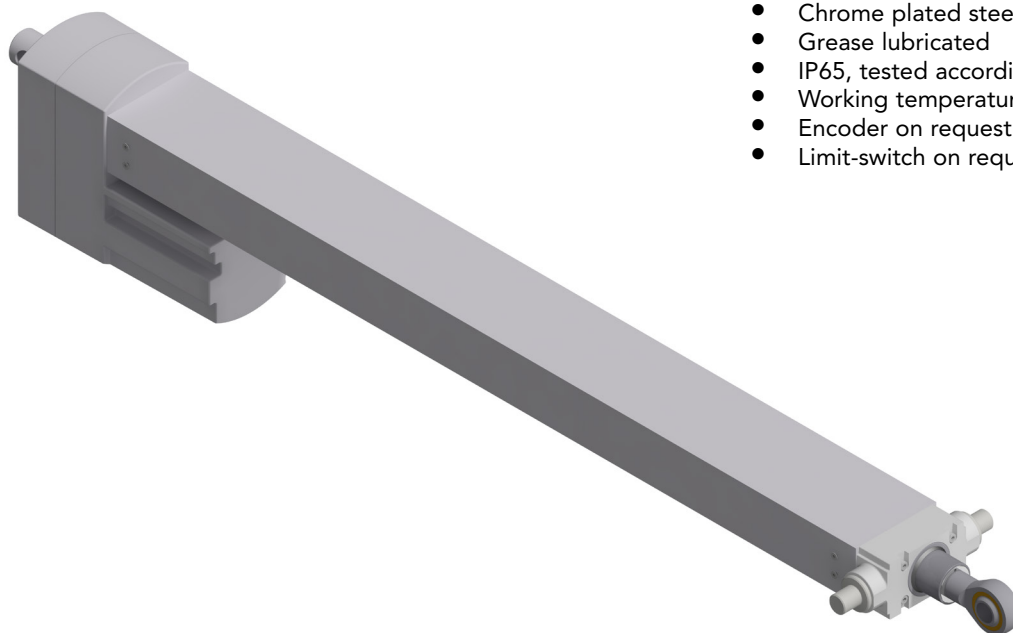

- Permanent magnet DC motor 12-24 V
- Steel cross gearbox
- Steel ACME lead screw
- Chrome plated steel push rod
- Grease lubricated
- IP65, tested according to rule CEI EN 60529
- Working temperature range -10°C +60°C
- Encoder on request
- Limit-switch on request

HP5 (Vdc)						
Fmax (N)	Speed (mm/s)	Version	Motor size	Motor speed (rpm)	Max Current for F max (A) 24Vdc **	Fs % base 5 min.
15000	2	M01	59	3400	6	30
10000	4	M02	63	3400	6	30
15000	3	M03	59	4900	9	10
10000	5,5	M04	63	4900	9	10
4000	20	M05	63	6000	10	10

When the stroke is longer than 350mm, check the STROKE SETUP section.

** For 12 Vdc power supply currents are doubled and loads are 20% lower.

BEFORE OPERATING ACTUATOR MAKE SURE YOU READ AND UNDERSTOOD BASIC OPERATIONAL INSTRUCTIONS SHOWN ON USERMANUALS, AVAILABLE FROM WEBSITE.

THIS DOCUMENT DISPLAYS MOST TYPICAL STANDARD FEATURES AND SETUPS: CONTACT OUR OFFICES FOR MORE. ACTUATOR SHALL NOT COME TO MECHANICAL STROKE-END, TO AVOID FAILURES. CONSIDER MECVEL's LIMITSWITCHES (MODEL ALI2-F or ALI2-FCM) OR PUT THEM ON MACHINE/FRAME.



MecVel reserves the right to change products information and/or features without notice; all data contained in this catalogue are purely indicative and not binding for the company.

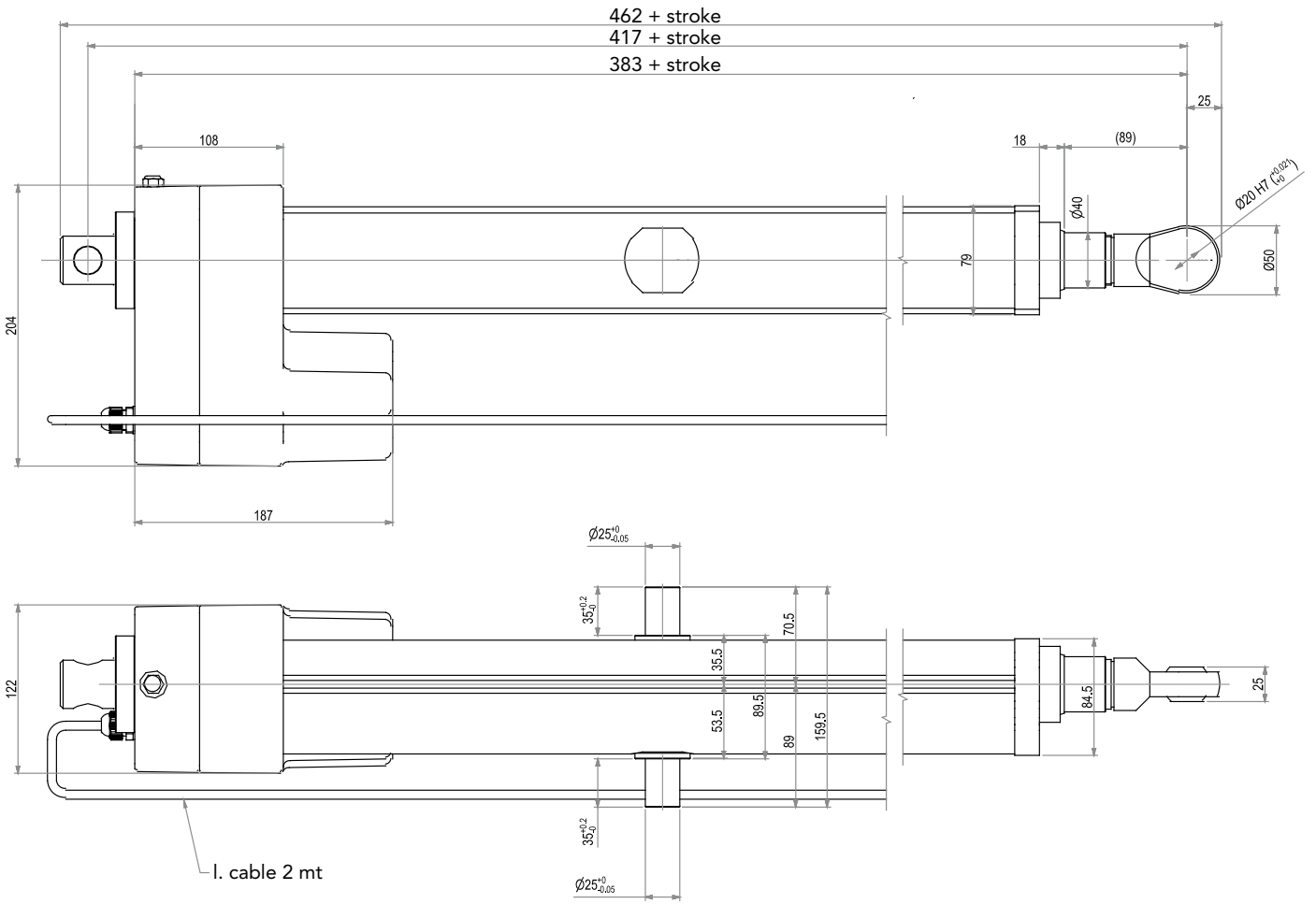

The pivots position can be arranged to the customer's needs.
Contact MecVel's staff for more information.

STROKE SETUP

Useful tips for handling stroke and avoid run-on-block collision.

- When stroke is more than 350 mm, add 50 mm extra-stroke as guidance, and put corresponding value in ordering-key.
- **WARNING SPEED-TIMING ALONG STROKELENGTH:** ramps are extremely important when speed is >30 mm/s!!! Inverter or PWM drive recommended!
- The more speed raises the more extra stroke has to raise too.

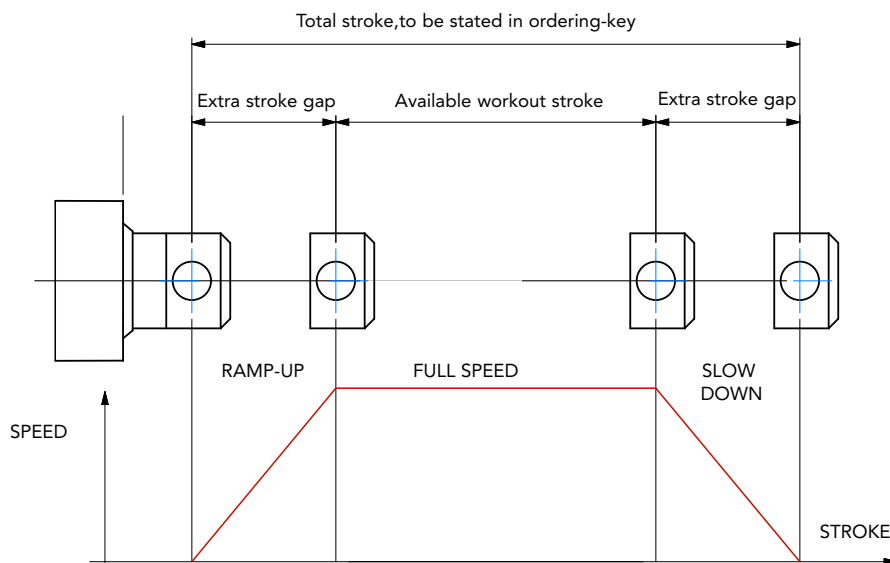

BUCKLING

When stroke is longer than 500mm, BUCKLING can be a risk: please check mounting with our offices and/or see usermanuals.

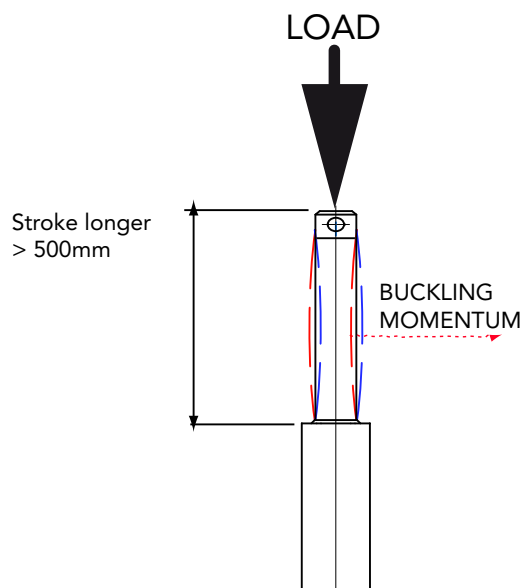

IMPORTANT:

Long strokes, even if load is low, can generate significant buckling momentums, as sketch shows. This happens when actuator is in its all-opened position: that's the reason why we recommend 100 mm extra-stroke. Pushtube will have this 100 mm-portion always inside the overtube, improving guidance against buckling.

For more information on this, contact our office.

HP5/0250/M02/CC-24-63-3400/FECC/E01/P1/A1/A+L/

MODEL _____
HP5

STROKE _____
es. 250 mm = 0250

VERSION _____
M01 / M02 / M03 / M04 / M05
M00 = Not standard speed

MOTOR _____
Indicate version, voltage, type, size, rpm

BRAKE _____
FECC AS-24 Vdc: brake with separated power supply
None: Leave blank

ENCODER _____
Options pg.76 None: Leave blank

REAR END _____
P0 without end (available only with OP option)
P1 eyelet (standard)
P2 eyelet90°
P3 special rear end (technical drawing needed)

FRONT END _____
A0 without end
A1 eyelet
A3 yoke + clip
A4 ball joint
A7 male M20x1,5
A9 special front end (technical drawing needed)

OPTIONS _____
A stainless steel version (push rod and front end)
FCD diode-wired mechanical limit switches
FCM magnetic limit switches
FX anti-corrosion protective painting
L anti-rotation device
OP swiveling version

VARIANTS _____
Drawing Nr.

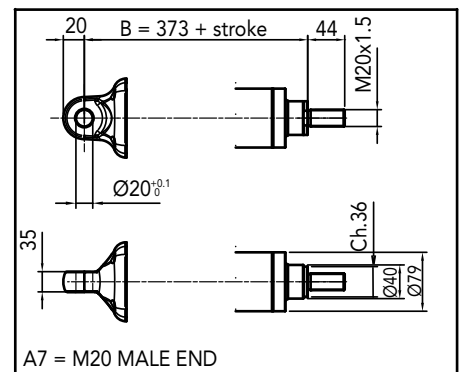
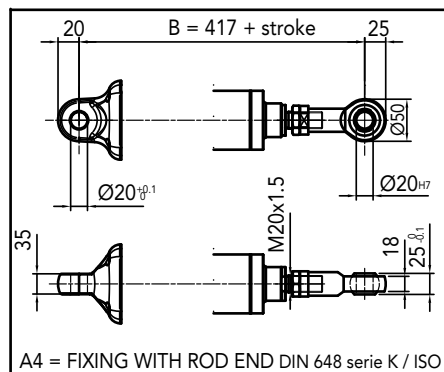
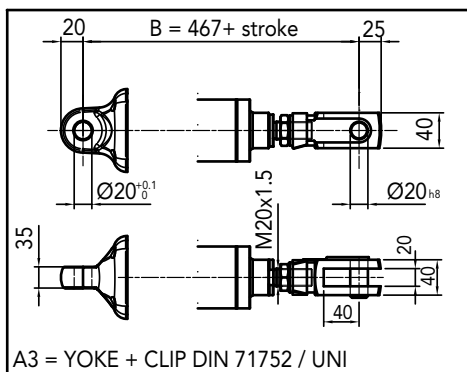



- Three phase or single phase AC motor
- Worm gearbox
- Acme lead screw or ballscrew (VRS)
- Chrome plated steel push road
- Grease (standard) or oil lubricated on request
- IP55, tested according to rule CEI EN 60529
NB: Only for brake motors Standard IP54, IP65 on request
- Working temperature range -10°C +60°C
- Intermittent duty S3 30% (5min) +30°C
- Limit switch, potentiometer, encoder on request
- At-Ex II 3 D T4 version (AC motor) on request

ALI5 (Vac 3-phase Acme lead screw)				
Fmax (N)	Speed (mm/s)	Version	Motor size	Motor power (KW)
4300 *	93	M01	IEC80	1.1 2 poles
7200 *	47	M02	IEC80	1.1 2 poles
11000	23	M03	IEC80	1.1 2 poles
18000	12	M04	IEC80	1.1 2 poles
18000	6	M05	IEC71	0.37 4 poles
18000	3	M06	IEC71	0.37 4 poles

ALI 5 VRS (Vac 3-phase ballscrew)				
Fmax (N)	Speed (mm/s)	Version	Motor size	Motor power (KW)
4800 *	93	M45	IEC71	0.55 2 poles
6000 *	47	M46	IEC71	0.37 2 poles
7500	23	M47	IEC71	0.37 2 poles
9500	12	M48	IEC71	0.25 4 poles
12000	6	M49	IEC71	0.25 4 poles

* When speed is more than 30 mm/s and/or strokes longer than 350mm, check STROKE SETUP section.

With single-phase motors type M (see motor choice guideline in paragraph ACCESSORIES) performances are 20% lower than the three-phase motor.

→ The brakemotor is strongly recommended

BEFORE OPERATING ACTUATOR MAKE SURE YOU READ AND UNDERSTOOD BASIC OPERATIONAL INSTRUCTIONS SHOWN ON USERMANUALS, AVAILABLE FROM WEBSITE.

THIS DOCUMENT DISPLAYS MOST TYPICAL STANDARD FEATURES AND SETUPS: CONTACT OUR OFFICES FOR MORE. ACTUATOR SHALL NOT COME TO MECHANICAL STROKE-END, TO AVOID FAILURES. CONSIDER MECVEL'S LIMITSWITCHES (MODEL ALI5-F or ALI5-FCM) OR PUT THEM ON MACHINE/FAME.



MecVel reserves the right to change products information and/or features without notice; all data contained in this catalogue are purely indicative and not binding for the company.

VERSION WITHOUT LIMITSWITCHES

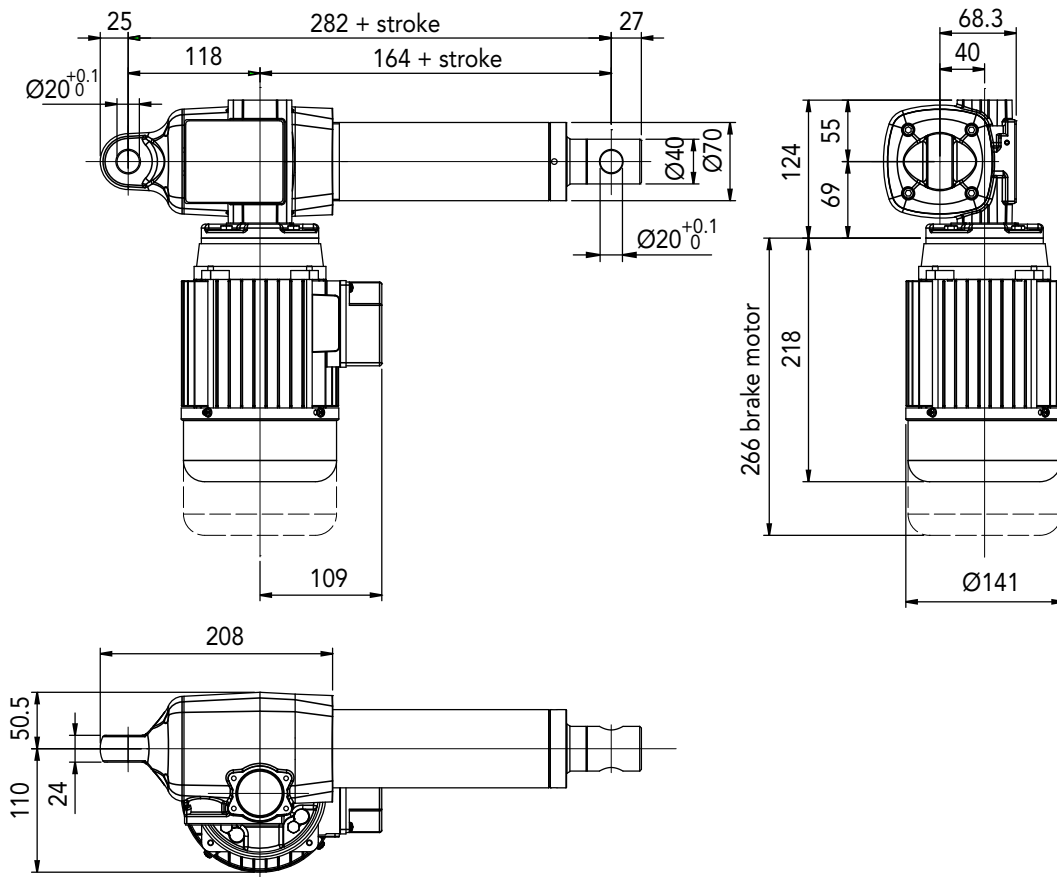

VERSION WITH LIMITSWITCHES

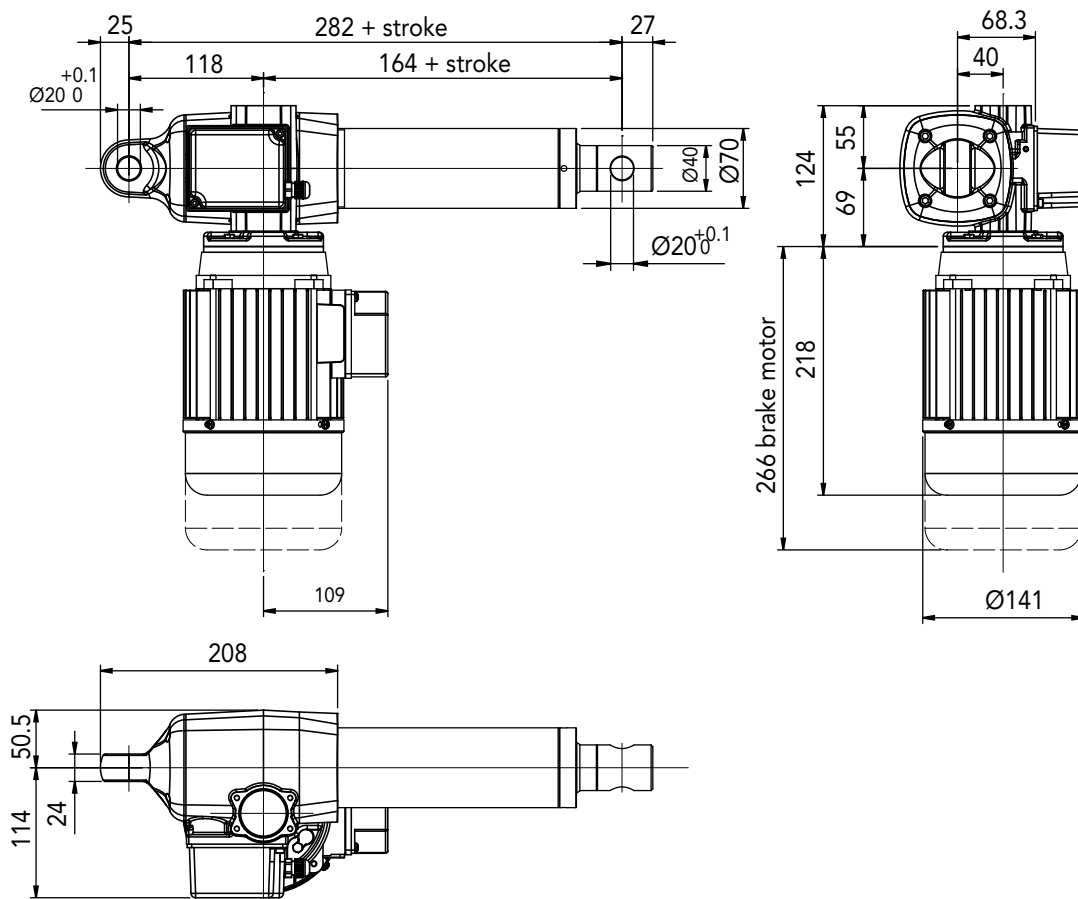

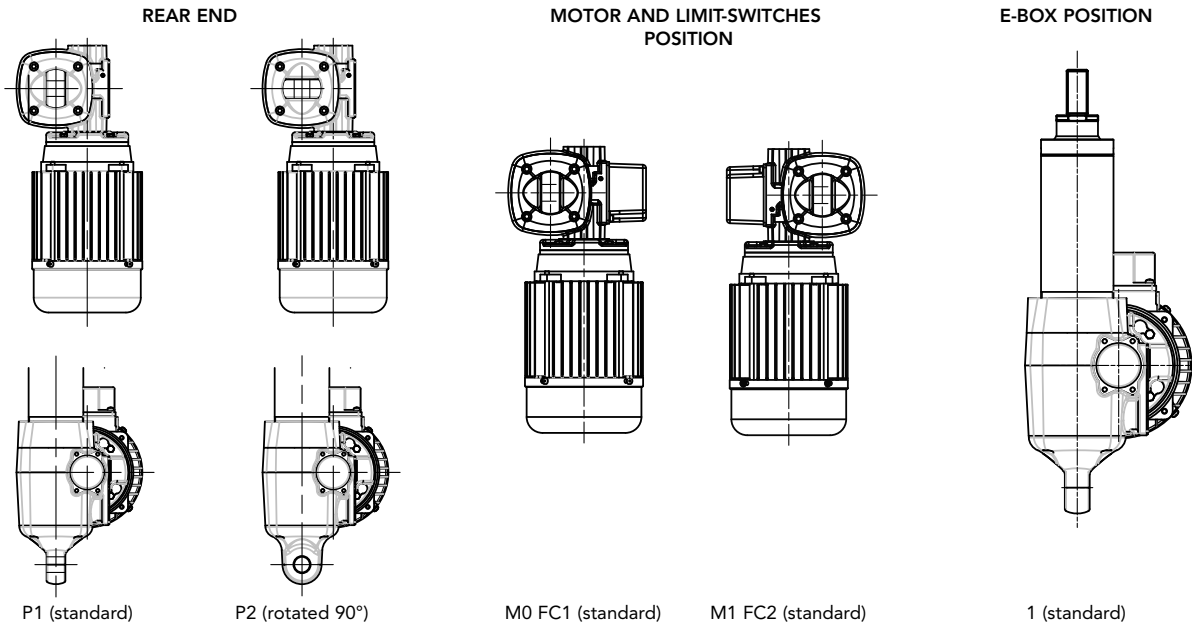

STROKE SETUP

Useful tips for handling stroke and avoid run-on-block collision.

- When stroke is more than 350 mm, add 50 mm extra-stroke as guidance, and put corresponding value in ordering-key.
- **WARNING SPEED-TIMING ALONG STROKELENGTH:** ramps are extremely important when speed is >30 mm/s!!! Inverter or PWM drive recommended!
- The more speed raises the more extra stroke has to raise too.

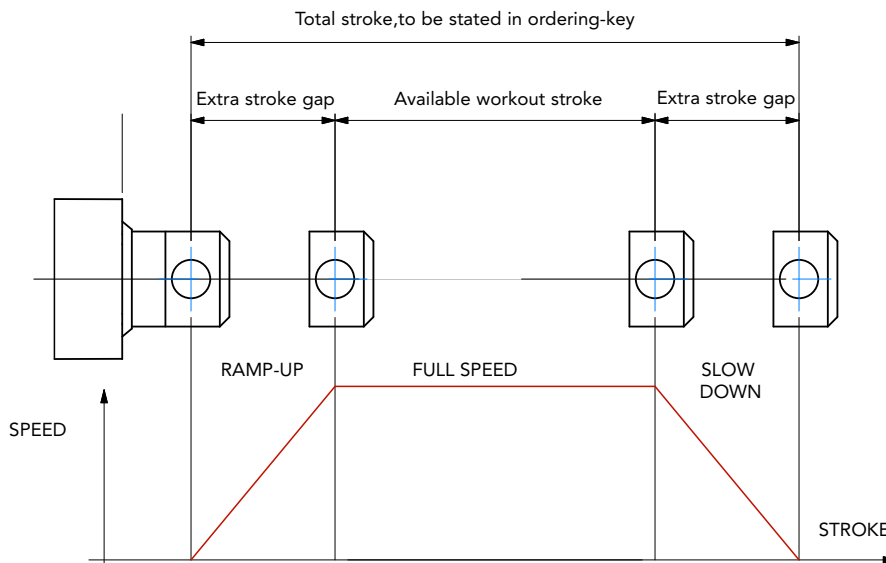

BUCKLING

When stroke is longer than 500mm, BUCKLING can be a risk: please check mounting with our offices and/or see usermanuals.

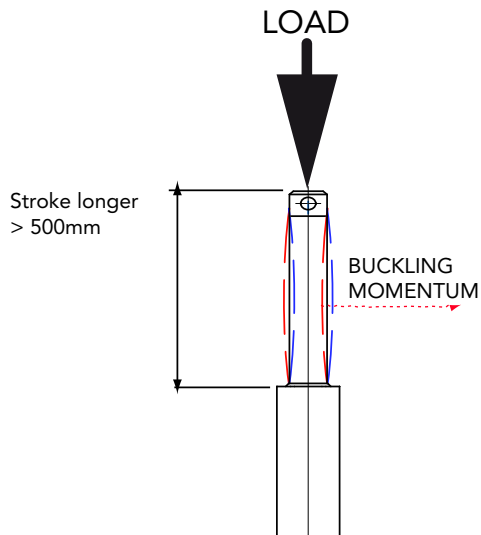

IMPORTANT:

Long strokes, even if load is low, can generate significant buckling momentums, as sketch slows. This happens when actuator is in its all-opened position: that's the reason why we recommend 100 mm extra-stroke. Pushtube will have this 100 mm-portion always inside the overtube, improving guidance against buckling.

For more information on this, contact our office.

ALI5/0250/M05/CA-400/50-T-71-4-0,37/AB/M0/1/E06/2FC1/POT01A/FC1/P1/A1/

MODEL

ALI5 / ALI5-F / ALI5 VRS / ALI5-F VRS / ALI5-FCM / ALI5-FCM VRS / ALI5-FCI / ALI5-FCI VRS

STROKE

es. 300 mm = 0300

VERSION

M01 / M02 / M03 / M04 / M05 / M06 / M45 / M46 / M47 / M48 / M49

M00 = Not standard speed

Flanged version = advice reduction ratio and screw pitch

MOTOR

AC: version, voltage, type, size, n°pole, power

With motorflange only put 0

With special motorflange put: PD

AC MOTOR OPTIONS

Motorflange: for motorflange version only advise size - i.e.for IEC71 B14 put 71B14

No motor: leave all following parameters blank

Protection Degree: IP65, for selfbrake motor IP54 standard

Brake type: for brakemotors only: ES. FECA

MOTOR POSITION

M0 M1 None: Leave blank

LIMIT SWITCHES

2FC1 None: Leave blank

LIMIT SWITCHES POSITION

FC1 FC2 None: Leave blank

E-BOX POSITION

1 No Motor: Leave blank

ENCODER

Options pg.76 None: Leave blank

POTENTIOMETER

POT01A (1Kohm) POT10A (10Kohm) None: Leave blank

REAR END

P1 = Eyelet (standard) P2 = Eyelet (90°)

FRONT END

A1 = Eyelet (standard) A3 = Yoke + CliP A4 = Rod end A7 = M20 male

NOTE: COMPLETE THE ORDERING KEY ADDING THE OPTIONS YOU CAN FIND IN THE "ACCESSORIES AND OPTIONS" SECTION

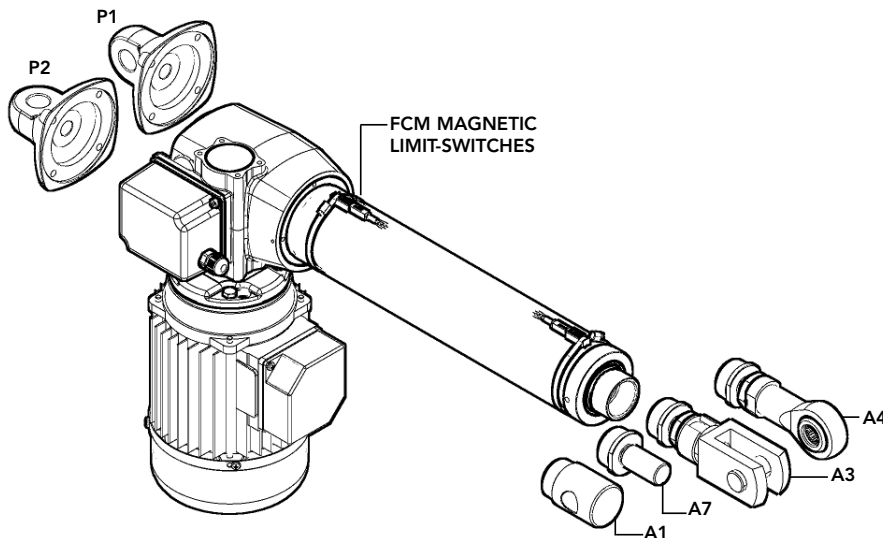

Note: "B" dimension variations depending on model

- ALI5 / ALI5-F = See pictures
- ALI5 / ALI5-F stroke > 500 = + 20 mm
- ALI5-FCM stroke < 500 = + 40 mm
- ALI5-FCM stroke > 500 = + 60 mm
- ALI5-FCI stroke < 500 = + 30 mm
- ALI5-FCI stroke > 500 = + 50 mm
- ALI5-VRS ALI5-F-VRS stroke < 500 = + 88 mm
- ALI5-VRS ALI5-F-VRS stroke > 500 = + 108 mm
- ALI5-VRS-FCM corsa stroke < 500 = + 128 mm
- ALI5-VRS-FCM stroke > 500 = + 148 mm
- ALI5-VRS-FCI stroke < 500 = + 118 mm
- ALI5-VRS-FCI stroke > 500 = + 138 mm
- ALI5 with safety nut "G" = + 50 mm
- ALI5 with antirotation device "L" = + 15 mm
- ALI5 with bellows = +25 (excluding FCM and FCI version)

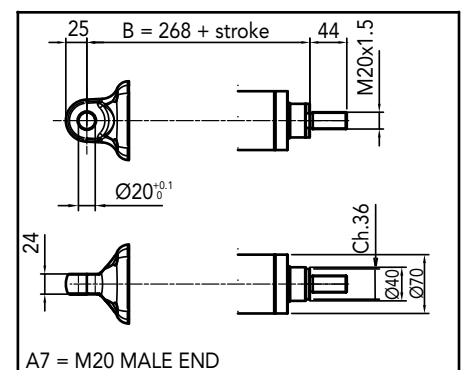
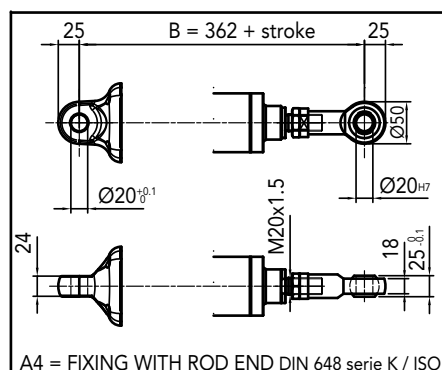
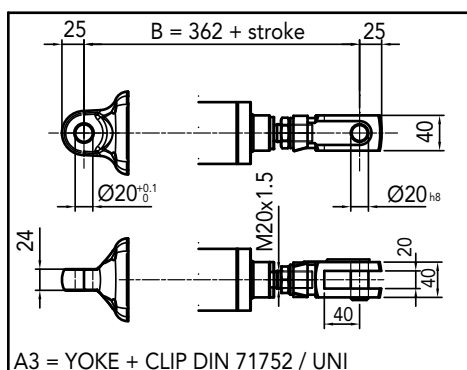

- Three phase or single phase AC motor
- Cross gears (ALI5-P)
- Belt drive (ALI5-PB)
- Acme lead screw or ballscrew (VRS)
- Chrome plated steel push road
- Grease (standard) or oil lubricated (on request)
- IP55, tested according to rule CEI EN 60529
NB: Only for brake motors Standard IP54, IP65 on request
- Working temperature range -10°C +60°C
- Intermittent duty S3 30% (5min) a +30°C
- Limit switch, potentiometer, encoder on request
- At-Ex II 3 D T4 version (A.C.motor) on request

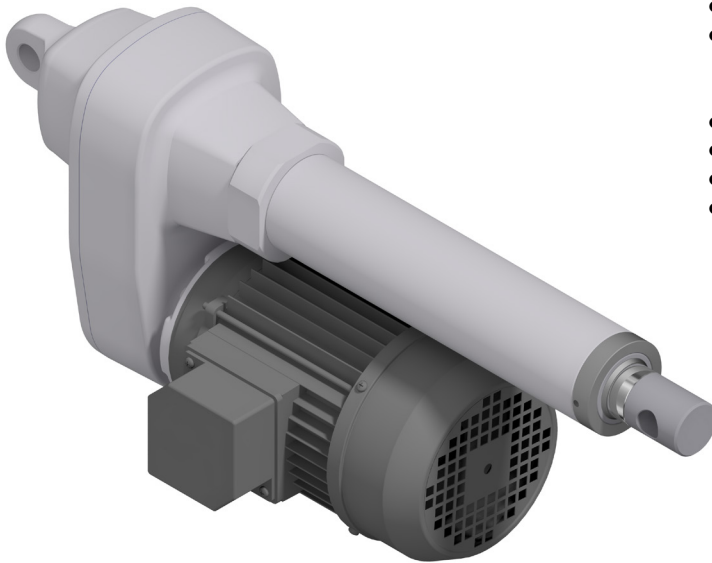

ALI5-P (Vac 3-phase)				
Fmax (N)	Speed (mm/s)	Version	Motor size	Motor power (KW)
2700 *	113	M11	IEC71	0.75 2 poles
4000 *	57	M12	IEC71	0.55 4 poles
6600	28	M13	IEC71	0.55 4 poles
15000	14	M14	IEC71	0.55 4 poles
15000	9	M15	IEC71	0.37 4 poles
15000	5	M16	IEC71	0.25 4 poles

ALI 5-PB VRS (Vac 3-phase)				
Fmax (N)	Speed (mm/s)	Version	Motor size	Motor power (KW)
3600 *	233	M61	IEC80	1.1 2 poles
3800 *	194	M62	IEC80	1.1 2 poles
4300 *	117	M63	IEC80	0.75 4 poles
4500 *	97	M64	IEC80	0.55 4 poles
4500 *	49	M65	IEC71	0.25 4 poles

* When speed is more than 30 mm/s and/or strokes longer than 350mm, check STROKE SETUP section.

With single-phase motors type M (see motor choice guideline in paragraph ACCESSORIES) performances are 20% lower than the three-phase motor.

→ The brakemotor is strongly recommended

BEFORE OPERATING ACTUATOR MAKE SURE YOU READ AND UNDERSTOOD BASIC OPERATIONAL INSTRUCTIONS SHOWN ON USERMANUALS, AVAILABLE FROM WEBSITE.

THIS DOCUMENT DISPLAYS MOST TYPICAL STANDARD FEATURES AND SETUPS: CONTACT OUR OFFICES FOR MORE. ACTUATOR SHALL NOT COME TO MECHANICAL STROKE-END, TO AVOID FAILURES. CONSIDER MECVEL'S LIMITSWITCHES (MODEL ALI5-F or ALI5-FCM) OR PUT THEM ON MACHINE/FRAME.



MecVel reserves the right to change products information and/or features without notice; all data contained in this catalogue are purely indicative and not binding for the company.

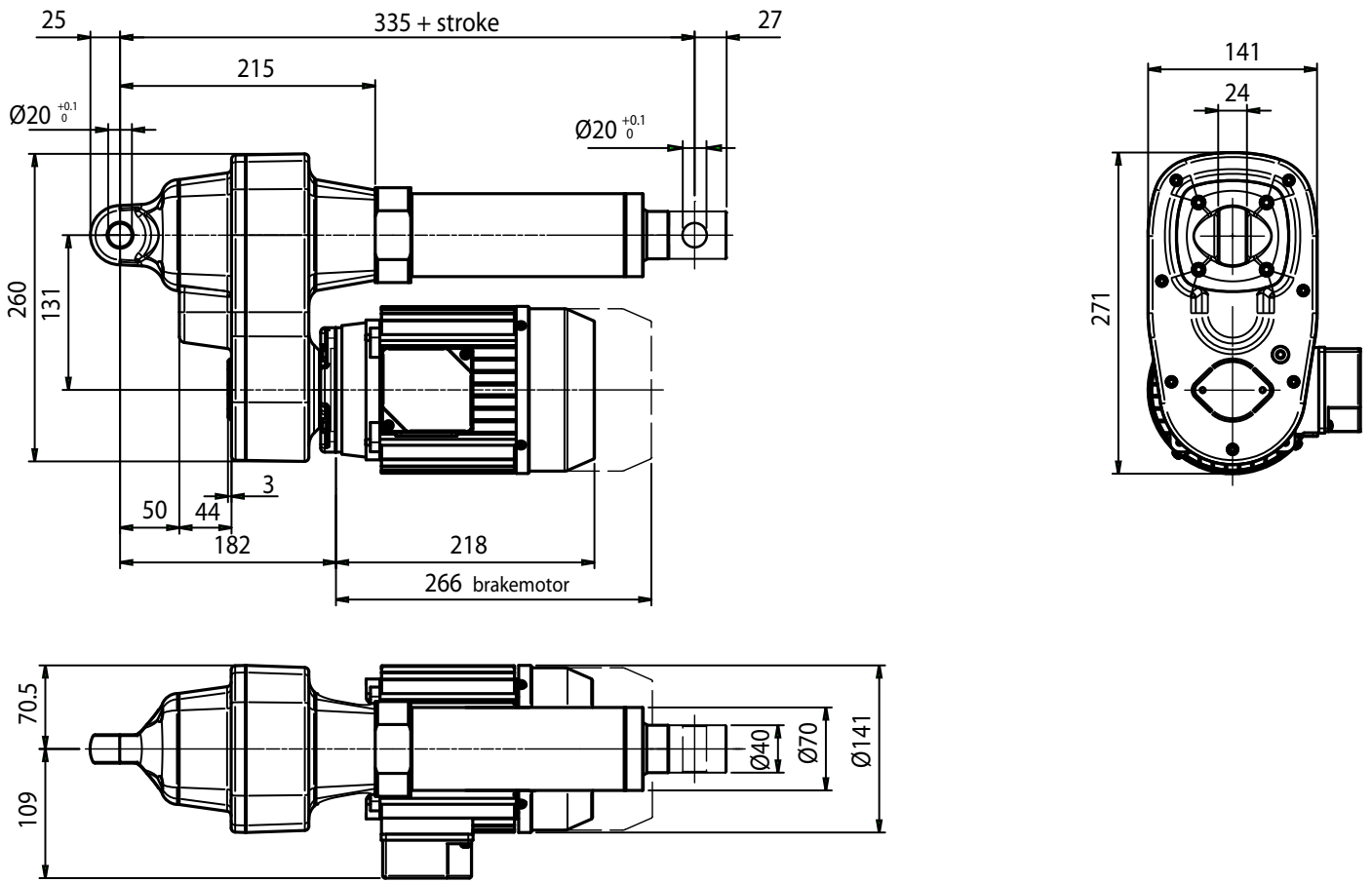

REAR END

E-BOX POSITION

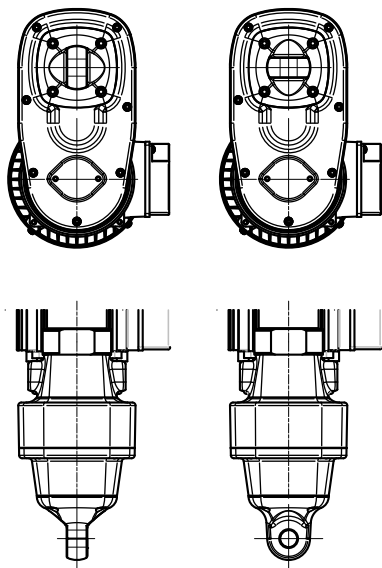

P1 (standard)

P2 (rotated 90°)

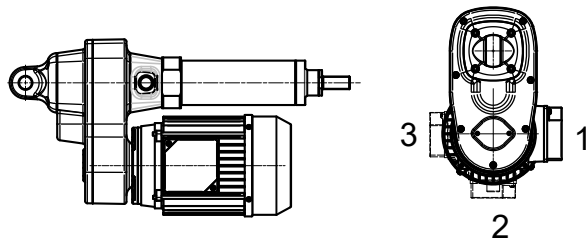

STROKE SETUP

Useful tips for handling stroke and avoid run-on-block collision.

- When stroke is more than 350 mm, add 50 mm extra-stroke as guidance, and put corresponding value in ordering-key.
- **WARNING SPEED-TIMING ALONG STROKELENGTH:** ramps are extremely important when speed is >30 mm/s!!! Inverter or PWM drive recommended!
- The more speed raises the more extra stroke has to raise too.

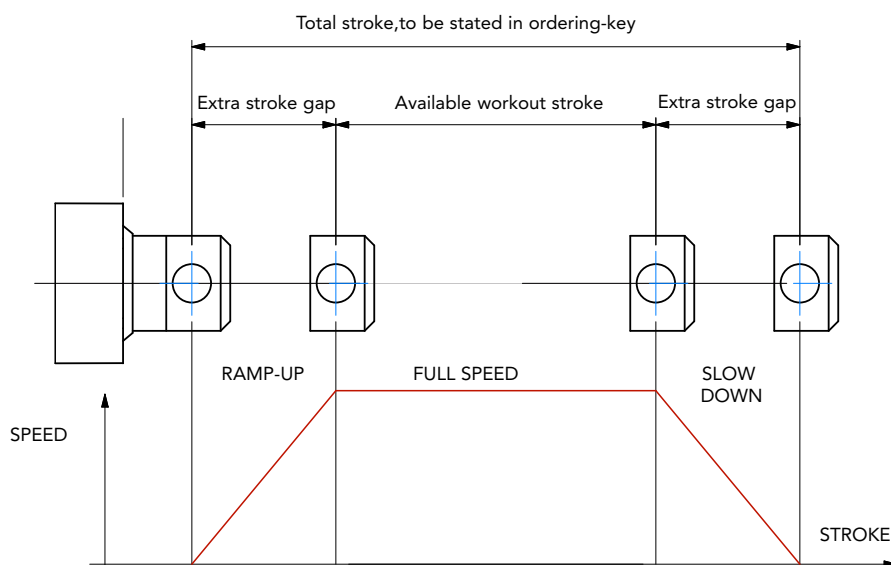

BUCKLING

When stroke is longer than 500mm, BUCKLING can be a risk: please check mounting with our offices and/or see usermanuals.

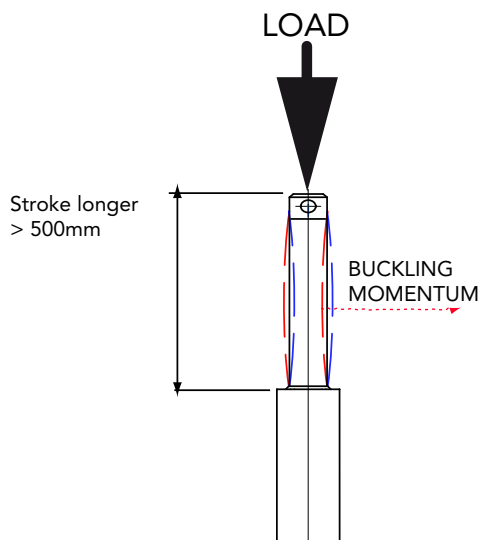

IMPORTANT:

Long strokes, even if load is low, can generate significant buckling momentums, as sketch shows. This happens when actuator is in its all-opened position: that's the reason why we recommend 100 mm extra-stroke. Pushtube will have this 100 mm-portion always inside the overtube, improving guidance against buckling.

For more information on this, contact our office.

ALI5-P/0250/M16/CA-400/50-T-71-4-0,25/AB/1/E06/2FCM0/POT01A/P1/A1/
MODEL

ALI5-P / ALI5-PB VRS / ALI5-P FCM / ALI5-P FCI

STROKE

es. 250 mm = 0250

VERSION

M11 / M12 / M13 / M14 / M15 / M16 (ALI5-P)

M61 / M62 / M63 / M64 / M65 (ALI5-PB)

M00 = Not standard speed

Flanged version = advice reduction ratio and screw pitch

MOTOR

AC version, voltage, type, size, nr. of poles, power

With motorflange only put 0

With special motorflange put: PD

AC MOTOR OPTIONS

Motorflange: for motorflange version only advise size - i.e. for IEC71 B14 put 71B14

Protection Degree: IP65, for selfbrake motor IP54 standard

Brake type: for brakemotors only (es. FECA)

Options: Advise if needed (es.. AB 2'shaft)

E-BOX POSITION

1

ENCODER

Options pg.76

None: Leave blank

LIMIT-SWITCHES

None: Leave blank

POTENTIOMETER

POT01A (1Kohm)

POT10A (10Kohm)

None: Leave blank

REAR END

P1 = Eyelet (standard)

P2 = Eyelet (90°)

FRONT END

A1 = Eyelet (standard)

A3 = Yoke + Clip

A4 = Rod end

A7 = M20 male

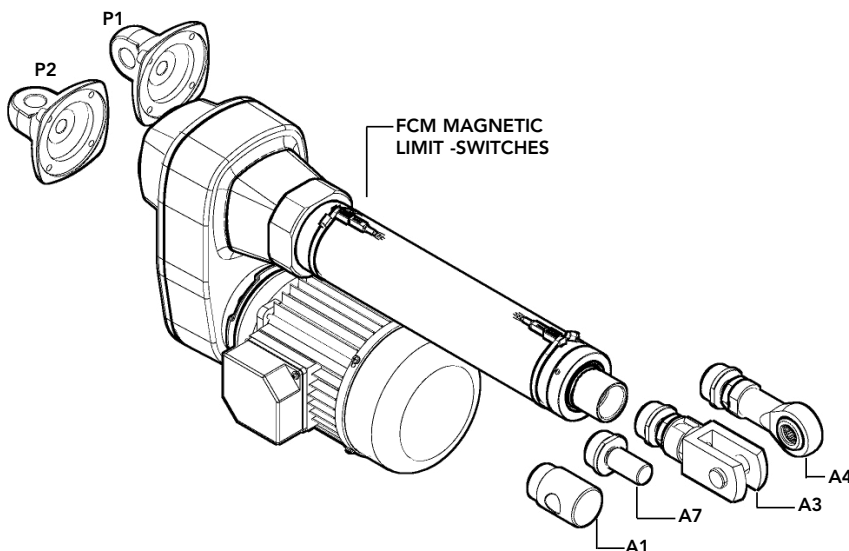
NOTE: COMPLETE THE ORDERING KEY ADDING THE OPTIONS YOU CAN FIND IN THE "ACCESSORIES AND OPTIONS" SECTION

Note: "B" dimension variations depending on model

ALI5-P = See pictures

ALI5-P stroke > 500 = + 20 mm

ALI5-P-FCM stroke < 500 = + 40 mm

ALI5-P-FCM stroke > 500 = + 60 mm

ALI5-P-FCI stroke < 500 = + 30 mm

ALI5-P-FCI stroke > 500 = + 50 mm

ALI5-P with safety nut "G" = + 50 mm

ALI5-P with antirotation device "L" = + 15 mm

ALI5-P with bellows = + 25 (excluding FCM and FCI version)

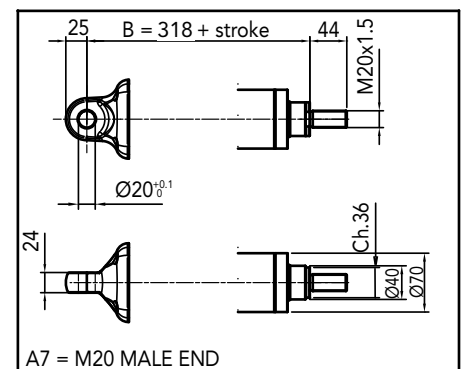
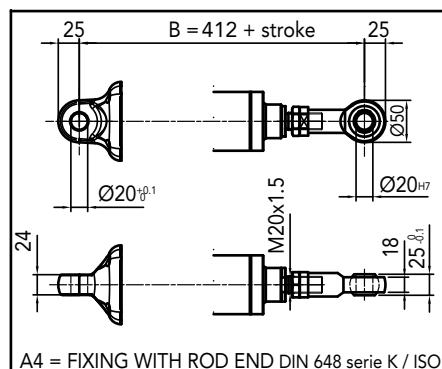
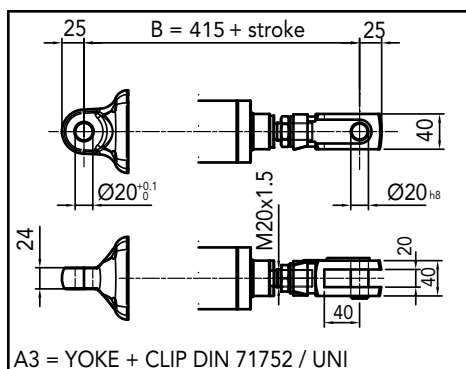

- AC motor, flange B14 - CE
- Worm gearbox
- Acme lead screw or ballscrew (VRS)
- Chrome plated steel push rod
- Grease Lubricated
- IP 55, tested according to rule CEI EN 60529
NB: Only for brake motors Standard IP54, IP65 on request
- Working temperature range -10°C +60°C
- Intermittent duty S3 30% (5 min) a 30°C
- Limit switches on request
- Potentiometer and encoder on request
- At-Ex II 3 D T4 version (A.C.motor) on request

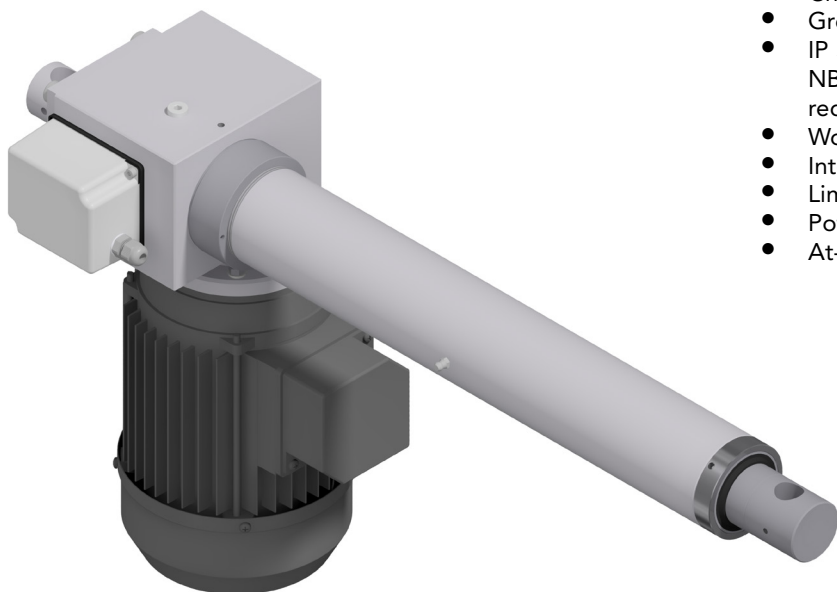

AV3 (Vac 3-phase)				
Fmax (N)	Speed (mm/s)	Version	Motor size	Motor power (KW)
13000 *	55	M01	IEC90	3 2 poli
20000	30	M02	IEC90	3 2 poli
25000	20	M03	IEC80	1.5 2 poli
25000	10	M04	IEC80	0.75 4 poli
25000	5	M05	IEC80	0.75 4 poli

AV3 VRS (ballscrew) (Vac 3-phase)				
Fmax (N)	Speed (mm/s)	Version	Motor size	Motor power (KW)
8000 *	45	M01	IEC80	0.75 2 poli
13000	22	M02	IEC80	0.55 4 poli
25000	15	M03	IEC80	0.75 2 poli
25000	7	M04	IEC80	0.55 4 poli

* When speed is more than 40 mm/s and/or strokes longer than 350mm, check STROKE SETUP section.

With single-phase motors type M (see motor choice guideline in paragraph ACCESSORIES) performances are 20% lower than the three-phase motor.

→ The brakemotor is strongly recommended

BEFORE OPERATING ACTUATOR MAKE SURE YOU READ AND UNDERSTOOD BASIC OPERATIONAL INSTRUCTIONS SHOWN ON USERMANUALS, AVAILABLE FROM WEBSITE.

THIS DOCUMENT DISPLAYS MOST TYPICAL STANDARD FEATURES AND SETUPS: CONTACT OUR OFFICES FOR MORE.

ACTUATOR SHALL NOT COME TO MECHANICAL STROKE-END, TO AVOID FAILURES.
CONSIDER MECVEL's LIMITSWITCHES (MODEL AV3-F or AV3-FCM) OR PUT THEM ON MACHINE/FRAME.



MecVel reserves the right to change products information and/or features without notice; all data contained in this catalogue are purely indicative and not binding for the company.

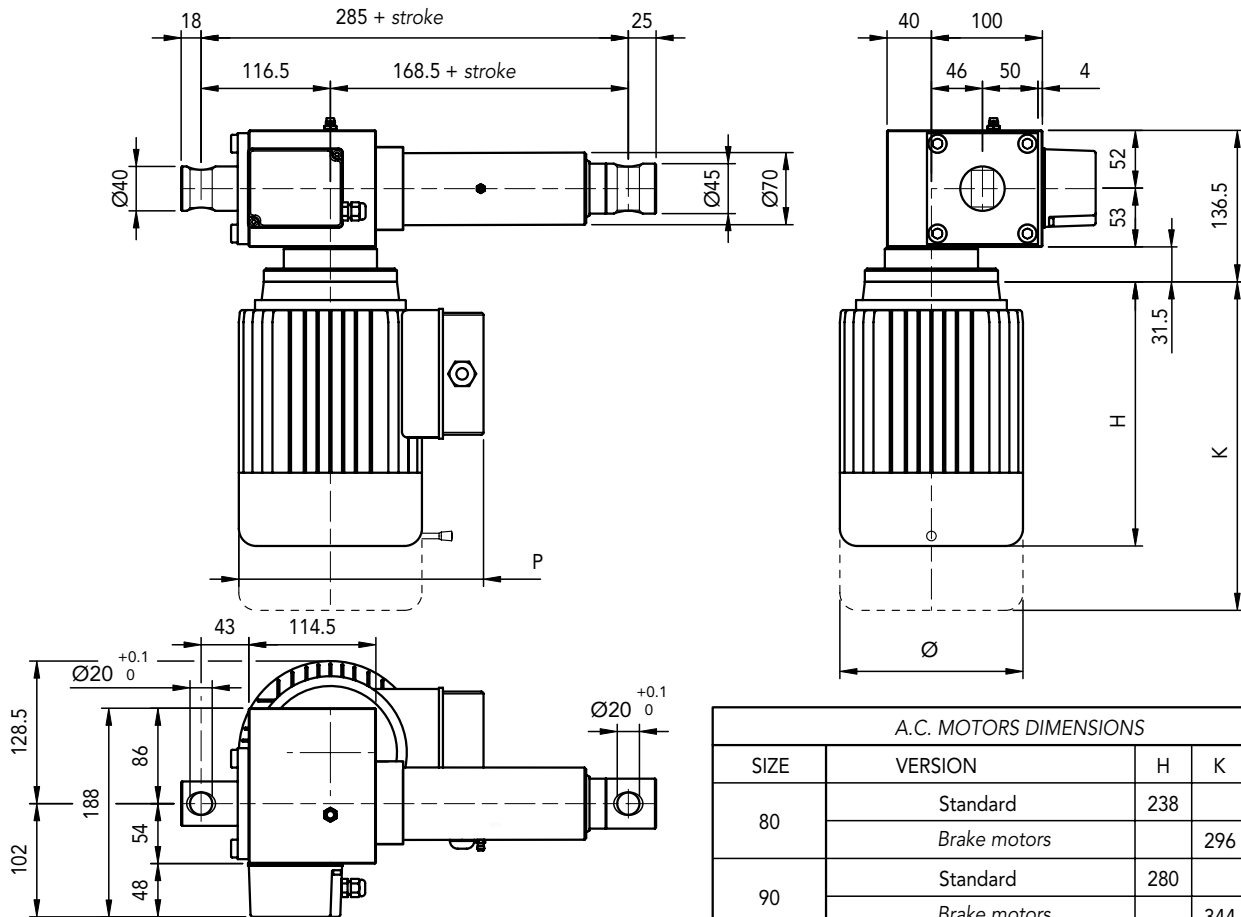

A.C. MOTORS DIMENSIONS					
SIZE	VERSION	H	K	Ø	P
80	Standard	238		165	220
	Brake motors		296		
90	Standard	280		182	251
	Brake motors		344		

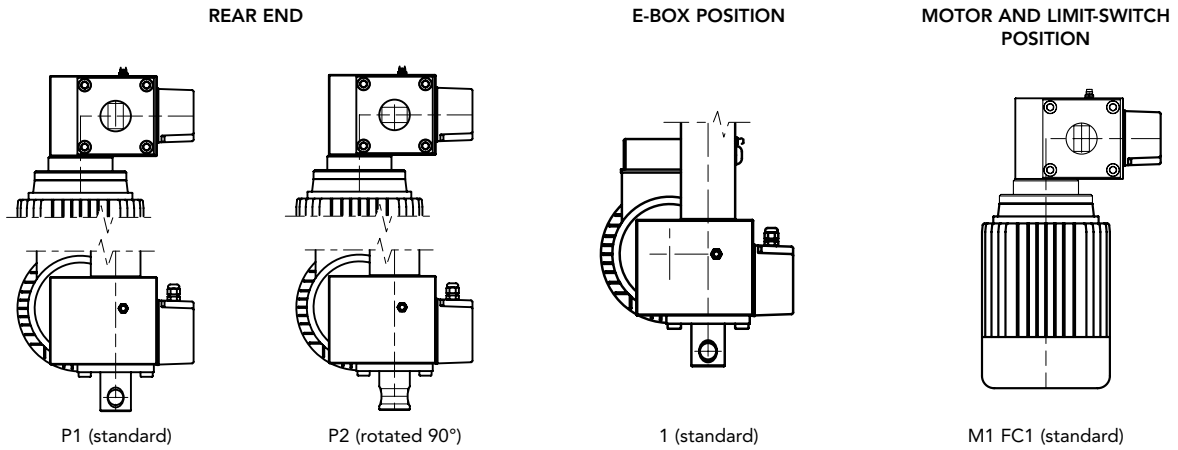

STROKE SETUP

Useful tips for handling stroke and avoid run-on-block collision.

- When stroke is more than 350 mm, add 50 mm extra-stroke as guidance, and put corresponding value in ordering-key.
- **WARNING SPEED-TIMING ALONG STROKELENGTH:** ramps are extremely important when speed is >30 mm/s!!! Inverter or PWM drive recommended!
- The more speed raises the more extra stroke has to raise too.

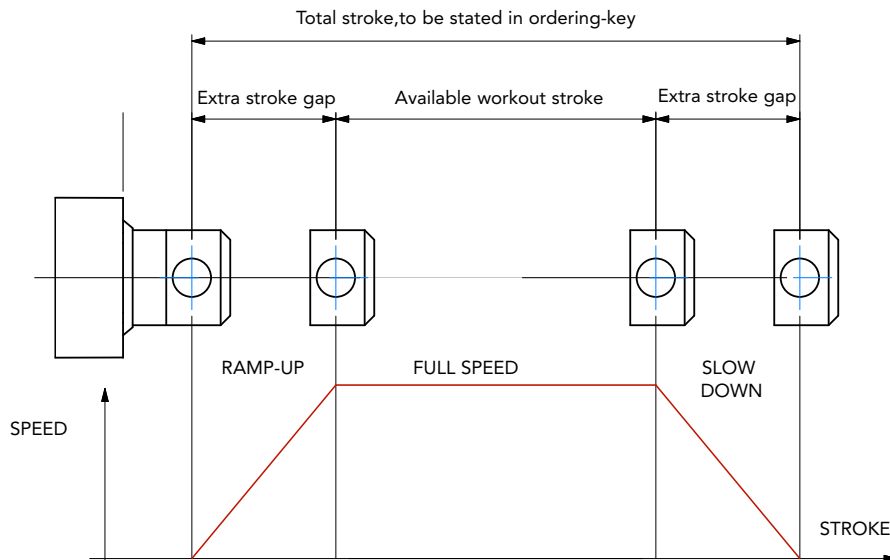

BUCKLING

When stroke is longer than 500mm, BUCKLING can be a risk: please check mounting with our offices and/or see usermanuals.

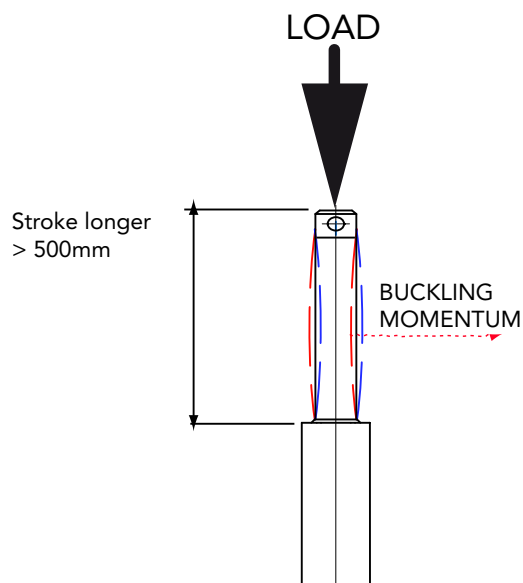

IMPORTANT:

Long strokes, even if load is low, can generate significant buckling momentums, as sketch slows. This happens when actuator is in its all-opened position: that's the reason why we recommend 100 mm extra-stroke. Pushtube will have this 100 mm-portion always inside the overtube, improving guidance against buckling.

For more information on this, contact our office.

AV3/0250/M05/CA-400/50-T-80-4-0,75/AB/M1-FC1/1/E06/2FC1/POT01A/P1/A1/

MODEL	AV3-VRS	
STROKE	es. 250 mm = 0250	
VERSION	M01 / M02 / M03 / M04 / M05 M00 = Not standard speed Flanged Version = Rpm, indicate reduction ratio and screw pitch	
MOTOR	Advise only if with motor: version, voltage, type, size, n°pole, power With motorflange only put 0 With special motorflange put: PD	
AC MOTOR OPTIONS	Motorflange: for motorflange version only advise size - i.e.for IEC80 B14 put 80B14 Protection Degree: IP65, for selfbrake motor IP54 standard Brake type: for brakemotors only (es. FECA) Options: Advise if needed (es. AB 2'shaft)	
MOTOR AND LIMIT SWITCHES POSITION	M1-FC1 None: Leave blank	
E-BOX POSITION	1 No Motor: Leave blank	
ENCODER	Options pg.76 None: Leave blank	
LIMIT SWITCHES	None: Leave blank	
POTENTIOMETER	POT01A (1Kohm) POT10A (10Kohm) None: Leave blank	
REAR END	P1 = Eyelet (standard) P2 = Eyelet (90°)	
FRONT END	A1 = Eyelet (standrad) A4 = Rod end A3 = Yoke + Clip A7 = M20 male	

NOTE: COMPLETE THE ORDERING KEY ADDING THE OPTIONS YOU CAN FIND IN THE "ACCESSORIES AND OPTIONS" SECTION

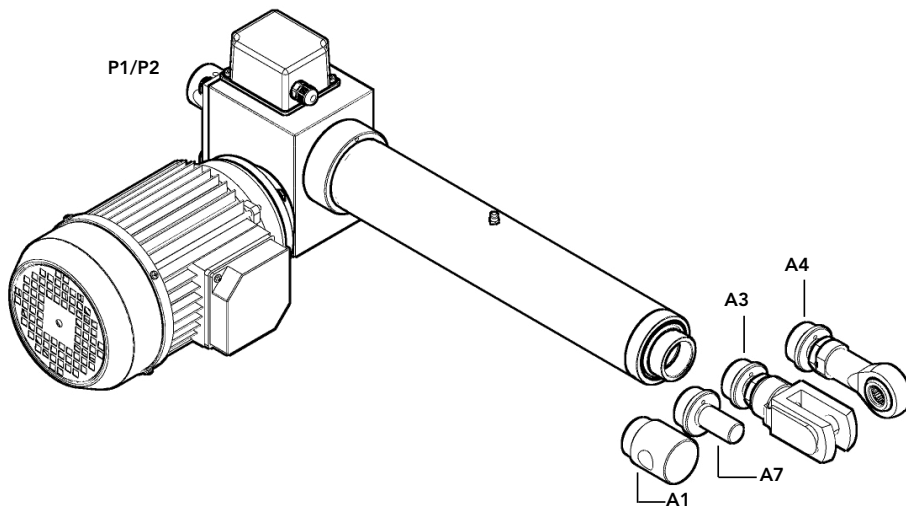

Note: "B" dimension changes according to model

AV3 = see picture
 AV3 with safety nut "G" = + 40 mm
 AV3-VRS = + 20 mm
 AV3 with Bellows = + 25mm

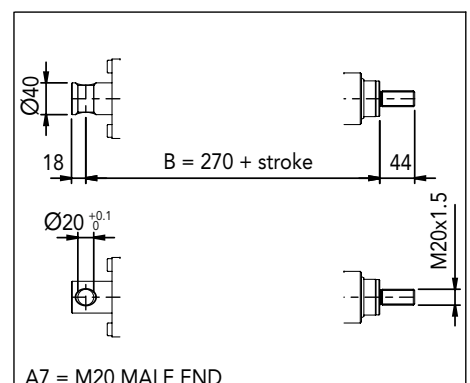
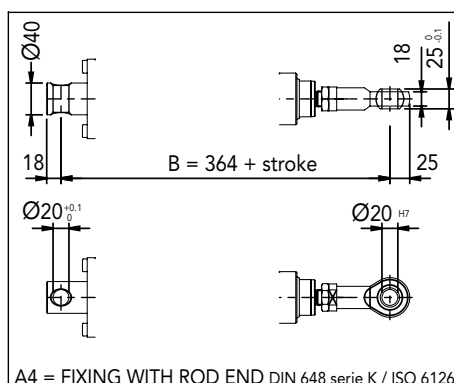
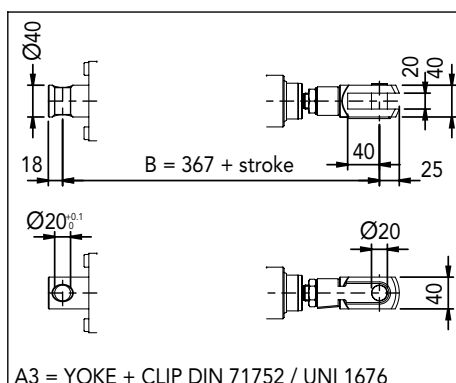

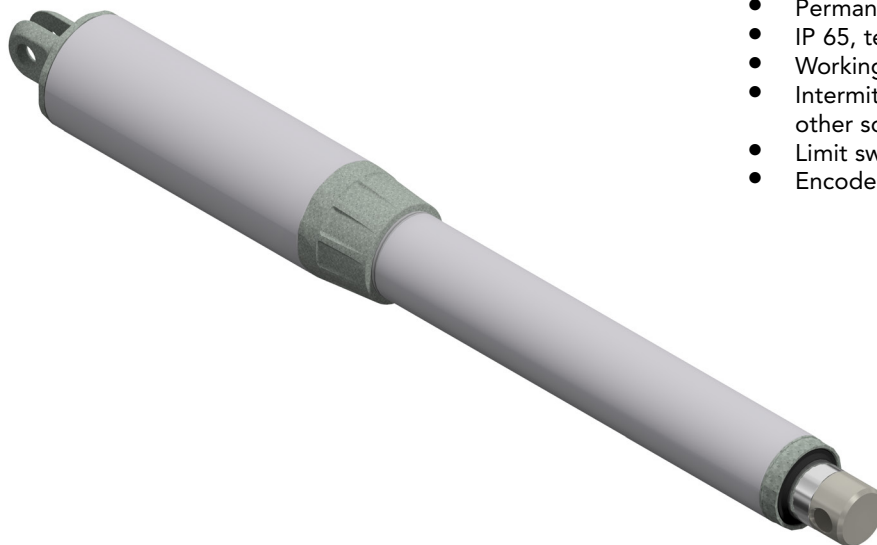

- Permanent magnet DC motor 12-24 V
- Planetary gearbox
- Acme lead screw or ballscrew (VRS)
- Chrome plated steel push rod
- Permanent grease lubrication
- IP 65, tested according to rule CEI EN 60529
- Working temperature range -10°C +60°C
- Intermittent duty (see performance charts) a 30°C, for other solutions contact the MecVel Technical dept.
- Limit switches on request
- Encoder on request

L02 (Vdc)					
Fmax (N)	Speed (mm/s)	Version	Motor size	Gearmotor speed (rpm)	Max Current for Fmax (A) 24Vdc**
750	30	M04	36	500	4
840	20	M05	36	150	2
1600	10	M06	36	150	2,5
2000	5	M07	36	80	2

When speed is more than 40 mm/s and/or strokes longer than 350mm, check STROKE SETUP section.

** For 12 Vdc power supply currents are doubled and loads are 20% lower.

ACTUATOR SHALL NOT COME TO MECHANICAL STROKE-END, TO AVOID FAILURES.

BEFORE OPERATING ACTUATOR MAKE SURE YOU READ AND UNDERSTOOD BASIC OPERATIONAL INSTRUCTIONS SHOWN ON USERMANUALS, AVAILABLE FROM WEBSITE.

THIS DOCUMENT DISPLAYS MOST TYPICAL STANDARD FEATURES AND SETUPS: CONTACT OUR OFFICES FOR MORE.

CONSIDER MECVEL's LIMITSWITCHES (MODEL L02-F or L02-FCM) OR PUT THEM ON MACHINE/FRAME.



MecVel reserves the right to change products information and/or features without notice; all data contained in this catalogue are purely indicative and not binding for the company.

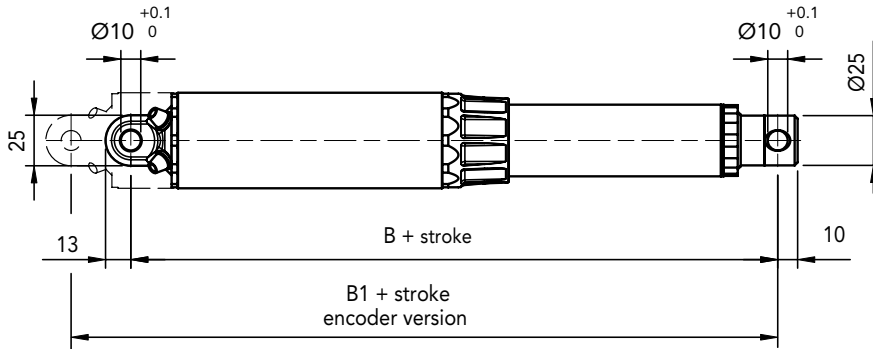
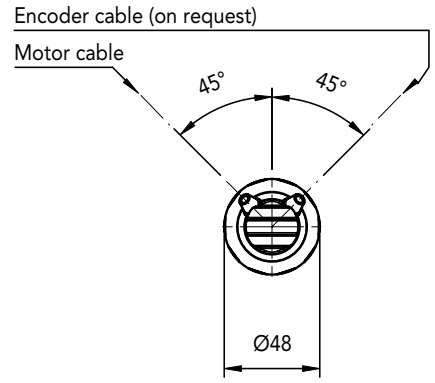
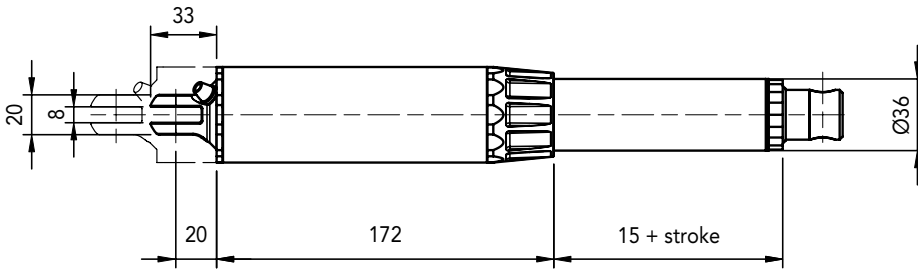

DIMENSION	stroke < 320 mm	stroke > 320 mm
B	228 + stroke	239 + stroke
B1	257 + stroke	268 + stroke

STROKE SETUP

Useful tips for handling stroke and avoid run-on-block collision.

- When stroke is more than 350 mm, add 50 mm extra-stroke as guidance, and put corresponding value in ordering-key.
- **WARNING SPEED-TIMING ALONG STROKELENGTH:** ramps are extremely important when speed is >30 mm/s!!! Inverter or PWM drive recommended!
- The more speed raises the more extra stroke has to raise too.

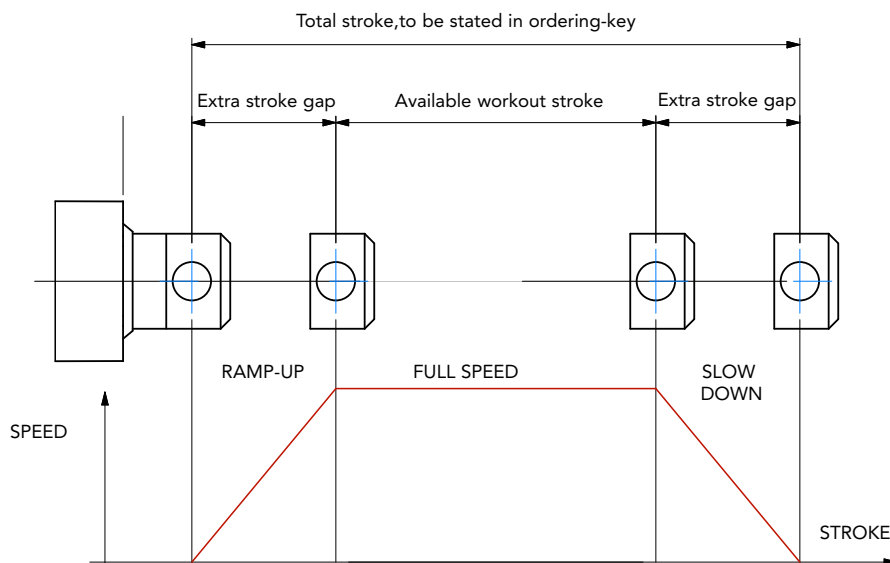

BUCKLING

When stroke is longer than 500mm, BUCKLING can be a risk: please check mounting with our offices and/or see usermanuals.

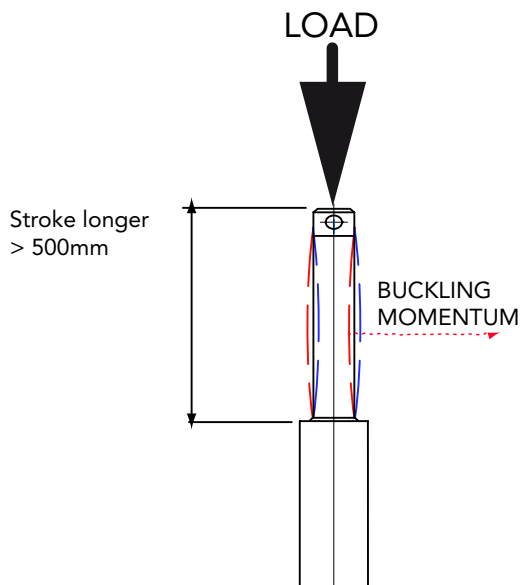

IMPORTANT:

Long strokes, even if load is low, can generate significant buckling moment, as sketch slows. This happens when actuator is in its all-opened position: that's the reason why we recommend 100 mm extra-stroke. Pushtube will have this 100 mm-portion always inside the overtube, improving guidance against buckling.

For more information on this, contact our office.

L02/0250/M07/24/E10/2FCM0/P1/A1/

MODEL _____
 L02 _____ L02-FCM _____

STROKE _____
 es. 250 mm = 0250 _____

VERSION _____
 M04 / M05 / M06 / M07 _____
 M00 = Not standard speed _____

MOTOR _____
 12 = 12 Vdc _____ 24 = 24 Vdc _____

LIMIT SWITCHES _____
 None: Leave blank _____

ENCODER _____
 options pg.76 _____ none: leave blank _____

REAR END _____
 P1 = Yoke (standard) _____ P2 = Special (provide drawing) _____

FRONT END _____
 A1 = Eyelet (standard) _____ A3 = Yoke + Clip _____
 A4 = Rod end _____ A7 = M10 male _____

NOTE: COMPLETE THE ORDERING KEY ADDING THE OPTIONS YOU CAN FIND IN THE "ACCESSORIES AND OPTIONS" SECTION

P1 / P2

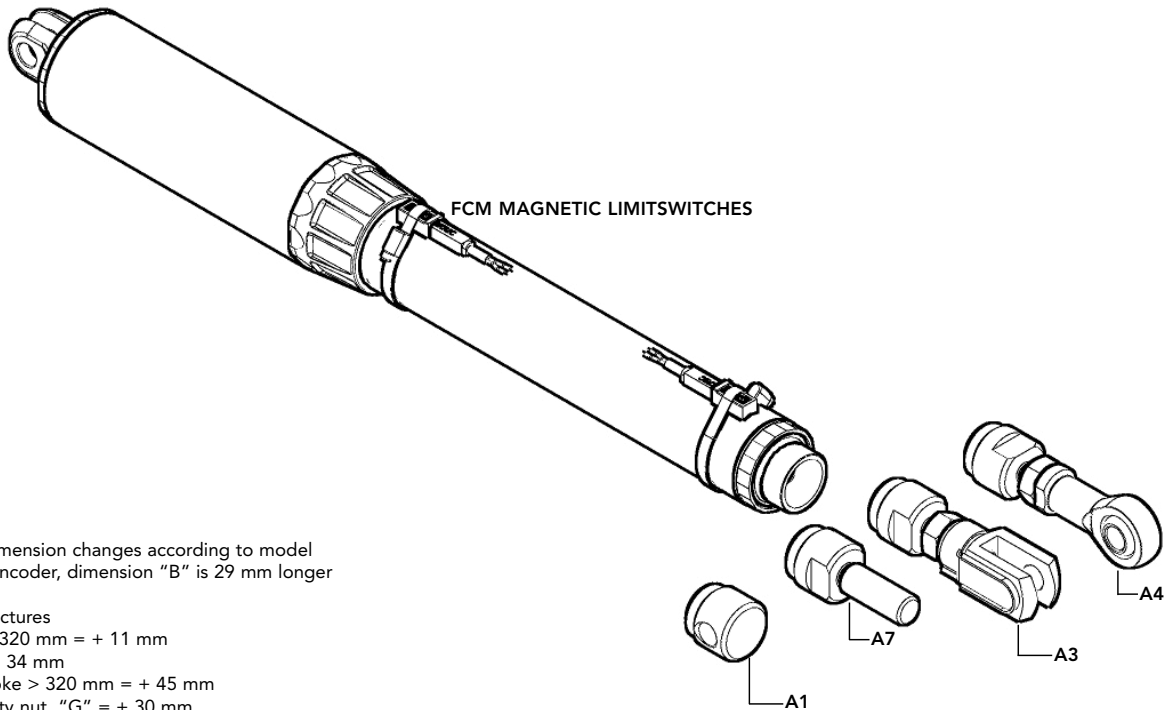

Note: "B" dimension changes according to model
Note: With encoder, dimension "B" is 29 mm longer

- L02 = See pictures
- L02 stroke > 320 mm = + 11 mm
- L02-FCM = + 34 mm
- L02-FCM stroke > 320 mm = + 45 mm
- L02 with safety nut "G" = + 30 mm
- L02-VRS = + 40 mm
- L02 with Bellows + 20mm (no for versions FCM)

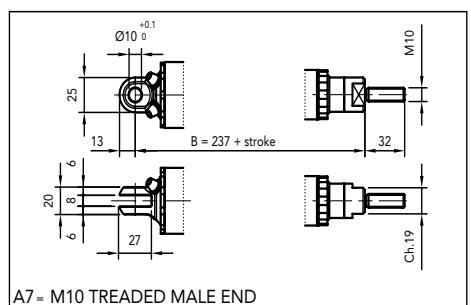
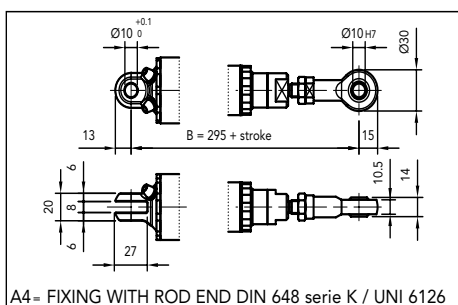
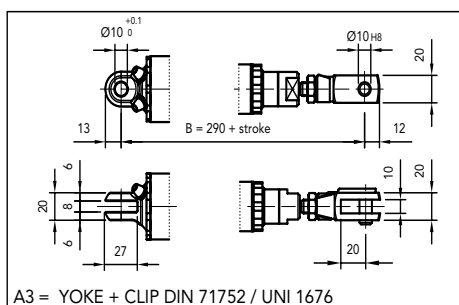

- Permanent magnet DC motor
- Planetary gearbox
- Acme lead screw or ballscrew (VRS)
- Chrome plated steel push rod
- Permanent grease lubrication
- IP65, tested according to rule CEI EN 60529
- Working temperature range -10°C +60°C
- Limit switches on request
- Encoder on request

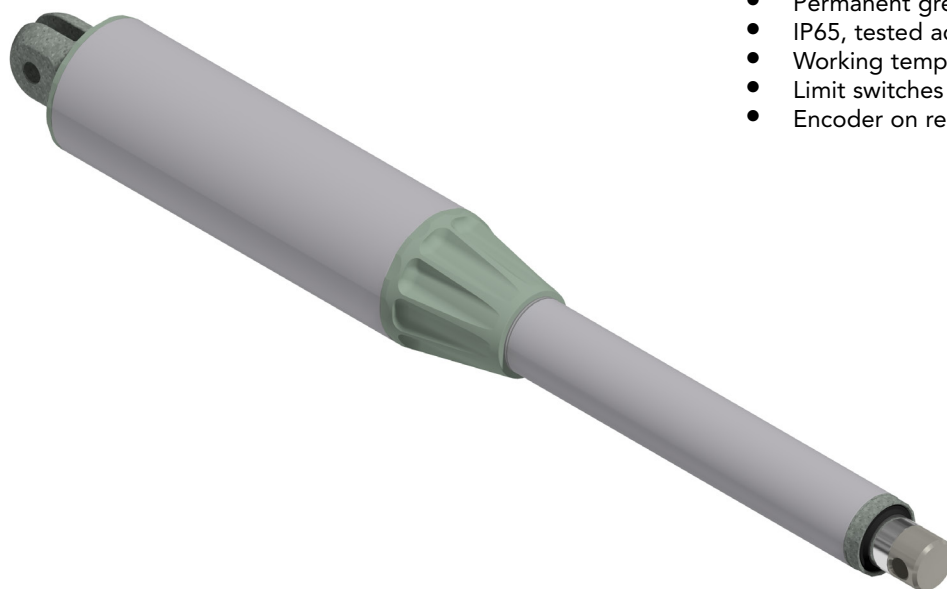

L03 (Vdc)						
Fmax (N)	Speed (mm/s)	Version	Motor size	Gearmotor speed (rpm)	Max Current for F max (A) 24Vdc**	Fs % base 5 min.
3000	20	M01	51	155	9	10
5000	10	M02	51	155	10,5	10
2000	30	M03	51	155	7,5	20

L03 VRS (ballscrew) (Vdc)						
Fmax (N)	Speed (mm/s)	Version	Motor size	Gearmotor speed (rpm)	Max Current for F max (A) 24Vdc	Fs % base 5 min.
5000	13	M01	51	155	5,5	30

When speed is more than 40 mm/s and/or strokes longer than 350mm, check STROKE SETUP section.

** For 12 Vdc power supply currents are doubled and loads are 20% lower.

BEFORE OPERATING ACTUATOR MAKE SURE YOU READ AND UNDERSTOOD BASIC OPERATIONAL INSTRUCTIONS SHOWN ON USERMANUALS, AVAILABLE FROM WEBSITE.

THIS DOCUMENT DISPLAYS MOST TYPICAL STANDARD FEATURES AND SETUPS: CONTACT OUR OFFICES FOR MORE.

ACTUATOR SHALL NOT COME TO MECHANICAL STROKE-END, TO AVOID FAILURES, CONSIDER MECVEL'S LIMITSWITCHES (MODEL L03-F or L03-FCM) OR PUT THEM ON MACHINE/FRAME.



MecVel reserves the right to change products information and/or features without notice; all data contained in this catalogue are purely indicative and not binding for the company.

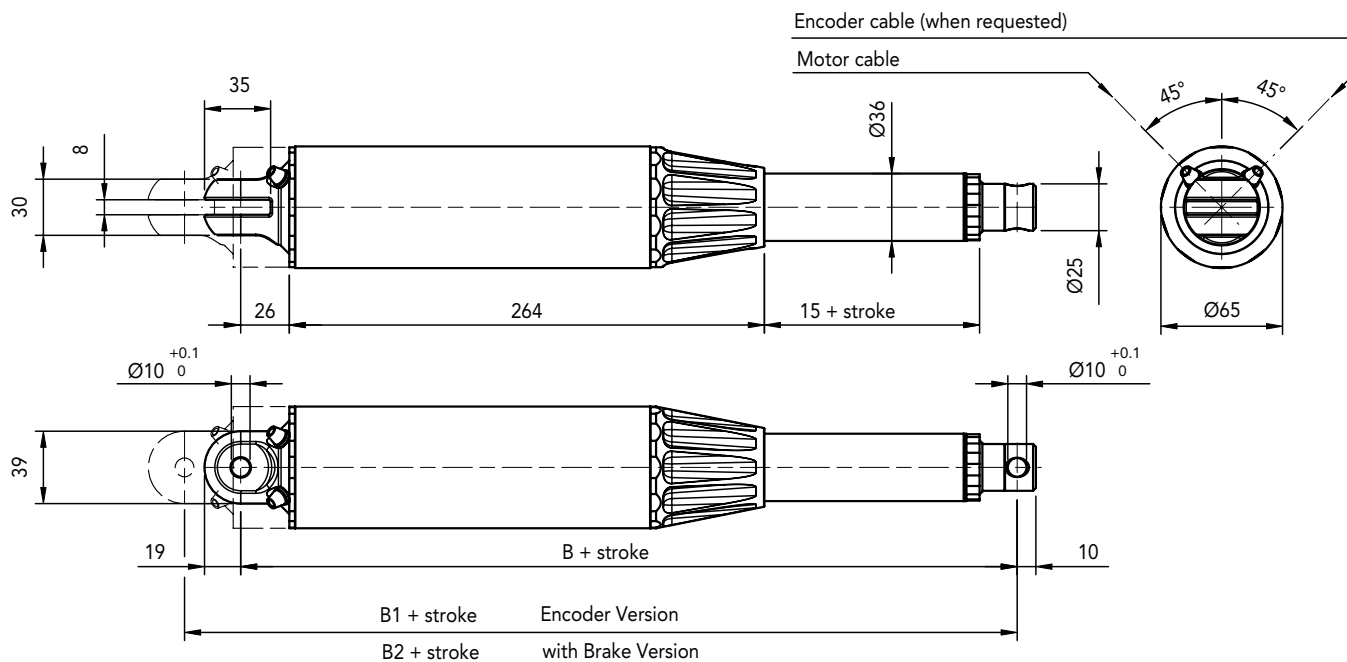

	DIMENSION	Stroke < to 320 mm.	Stroke > to 320 mm.
Version without Encoder and Brake	B	325 + stroke	336 + stroke
Version without Encoder (not compatible with brake version)	B1	355 + stroke	366 + stroke
Version without Brake (not compatible with encoder version)	B2	355 + stroke	366 + stroke

STROKE SETUP

Useful tips for handling stroke and avoid run-on-block collision.

- When stroke is more than 350 mm, add 50 mm extra-stroke as guidance, and put corresponding value in ordering-key.
- **WARNING SPEED-TIMING ALONG STROKELENGTH:** ramps are extremely important when speed is >30 mm/s!!! Inverter or PWM drive recommended!
- The more speed raises the more extra stroke has to raise too.

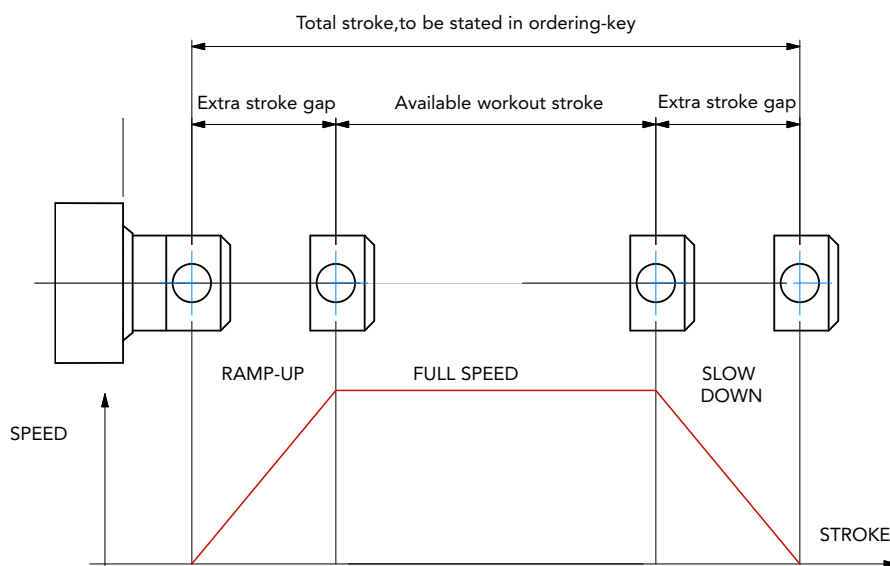

BUCKLING

When stroke is longer than 500mm, BUCKLING can be a risk: please check mounting with our offices and/or see usermanuals.

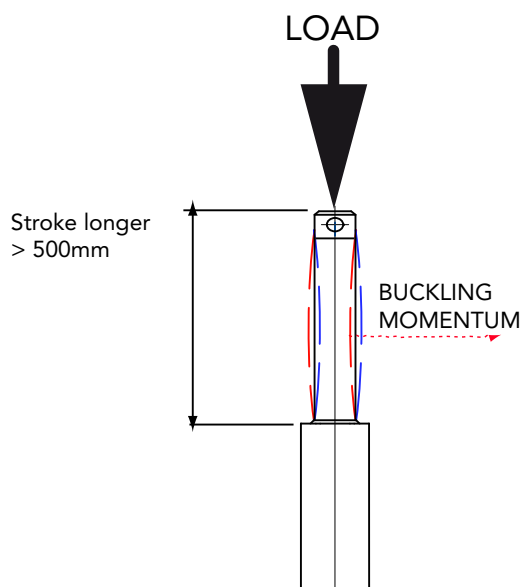

IMPORTANT:

Long strokes, even if load is low, can generate significant buckling momentums, as sketch shows. This happens when actuator is in its all-opened position: that's the reason why we recommend 100 mm extra-stroke. Pushtube will have this 100 mm-portion always inside the overtube, improving guidance against buckling.

For more information on this, contact our office.

L03/0250/M02/24/E50/2FCM0/P1/A1/

MODEL _____
 L03 L03 VRS L03-FCM

STROKE _____
 es. 250 mm = 0250

VERSION _____
 M01 / M02 / M03
 M00 = Not standard speed

MOTOR _____
 12 = 12 Vdc 24 = 24 Vdc

ENCODER _____
 Options pg.76 None: leave blank

LIMIT SWITCH _____
 None: leave blank

REAR END _____
 P1 = Yoke (standard) P2 = Special (provide technical drawing)

FRONT END _____
 A1 = Eyelet (standard) A3 = Yoke + Clip A4 = Rod end A7 = M10 male

NOTE: COMPLETE THE ORDERING KEY ADDING THE OPTIONS YOU CAN FIND IN THE "ACCESSORIES AND OPTIONS" SECTION

P1 / P2

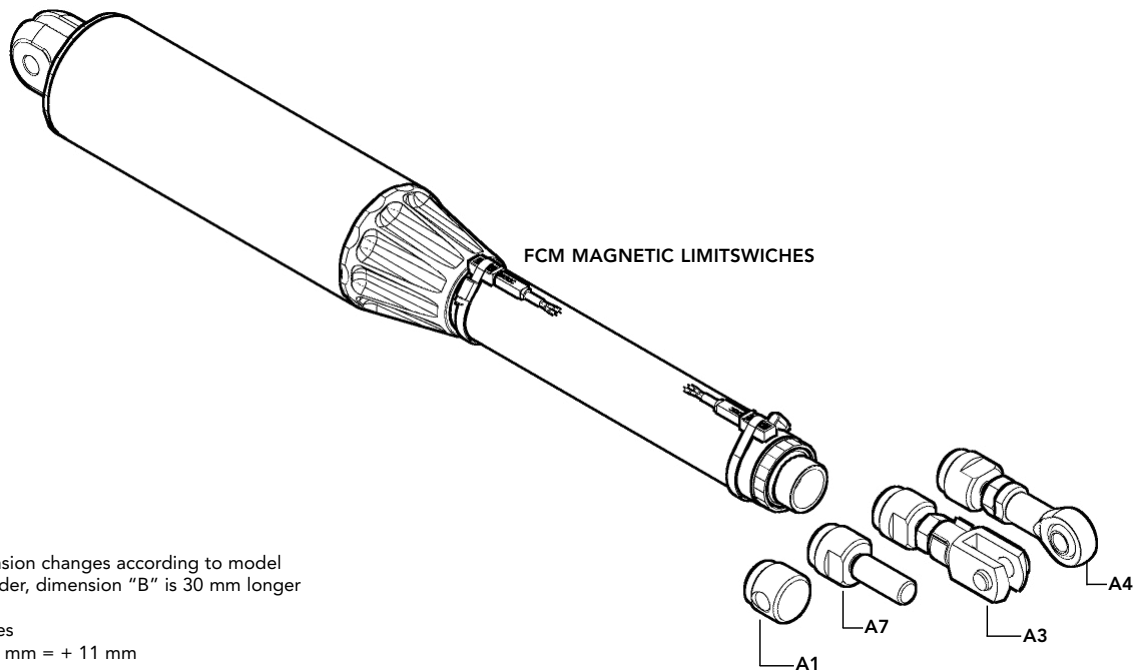

Note: "B" dimension changes according to model
Note: With encoder, dimension "B" is 30 mm longer

- L03 = See pictures
- L03 stroke > 320 mm = + 11 mm
- L03-FCM = + 34 mm
- L03-FCM stroke > 320 mm = + 44 mm
- L03-VRS = + 40 mm
- L03 with safety nut "G" = + 30 mm
- L03 with bellows = + 20 mm (not compatible with FCM)

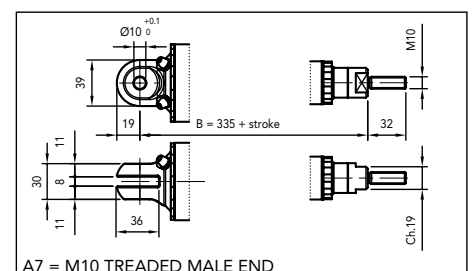
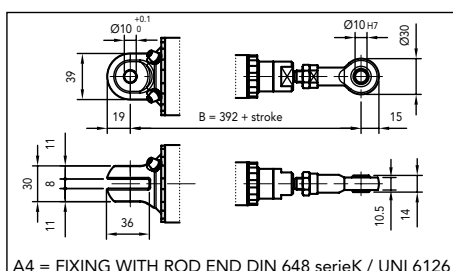
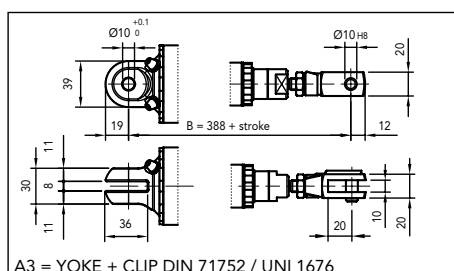

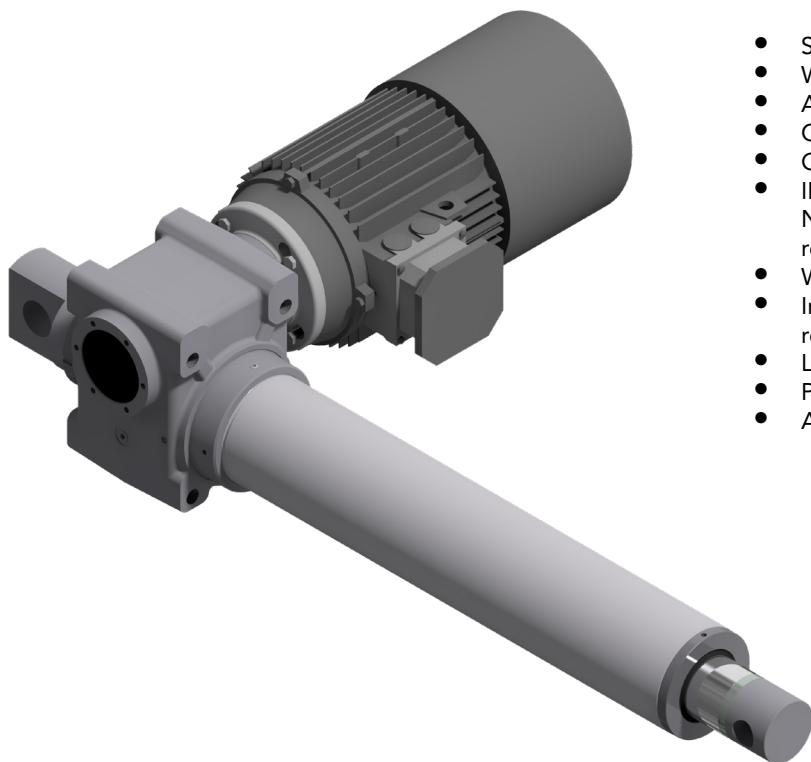

- Single-phase or tri-phase AC motor
- Worm gearbox
- Acme lead screw or ballscrew (VRS)
- Chrome plated steel push rod
- Grease Lubricated
- IP55, tested according to rule CEI EN 60529
NB: Only for brake motors Standard IP54, IP65 on request
- Working temperature range -10°C +60°C
- Intermittent duty S3 30% (5 min) a 30°C - for any other request contact MecVel technical dept.
- Limit switches on request
- Potentiometer and encoder on request
- At-Ex II 3 D T4 version (AC.motor) on request

HRS50 (Vac tri-phase)				
Fmax (N)	Speed (mm/s)	Version	Motor size	Motor power (KW)
18000 *	65	M01	IEC112	4 4 poli
29000 *	33	M02	IEC112	4 4 poli
36500	11	M03	IEC90	2.2 2 poli
50000	5	M04	IEC90	1.5 4 poli
HRS100 (Vca tri-phase)				
Fmax (N)	Speed (mm/s)	Version	Motor size	Motor power (KW)
38000 *	42	M01	IEC132	7.5 4 poli
58000	14	M02	IEC112	5.5 2 poli
87000	7	M03	IEC112	4 4 poli
100000	2	M04	IEC80	1.8 2 poli

HRS200 (Vac tri-phase)				
Fmax (N)	Speed (mm/s)	Version	Motor size	Motor power (KW)
44000 *	47	M01	IEC132	9.2 4 poli
90000	16	M02	IEC132	7.5 2 poli
130000	8	M03	IEC132	5.5 4 poli
200000	2	M04	IEC90	3 2 poli

HRS50 VRS (ballscrew) (Vac tri-phase)				
Fmax (N)	Speed (mm/s)	Version	Motor size	Motor power (KW)
30000 *	47	M01	IEC90	1.8 4 poli
45000	23	M02	IEC90	1.5 4 poli
50000	7	M04	IEC71	0.55 2 poli
50000	3	M05	IEC71	0.37 4 poli
HRS100 VRS (ballscrew) (Vac tri-phase)				
Fmax (N)	Speed (mm/s)	Version	Motor size	Motor power (KW)
51000 *	47	M01	IEC100	3 4 poli
70000	23	M02	IEC100	2.2 4 poli
92000	8	M03	IEC100	2.2 4 poli
100000	5	M04	IEC71	0.75 2 poli
100000	2	M05	IEC71	0.55 2 poli
HRS200 VRS (ballscrew) (Vac tri-phase)				
Fmax (N)	Speed (mm/s)	Version	Motor size	Motor power (KW)
125000 *	49	M01	IEC132	9.2 4 poli
150000	32	M02	IEC132	7.5 2 poli
200000	16	M04	IEC132	5.5 4 poli
200000	6	M05	IEC90	2.2 2 poli

* When speed is more than 30 mm/s and/or strokes longer than 350mm, check STROKE SETUP section

With single-phase motors type M (see in paragraph ACCESSORIES) performances are 20% lower than the three-phase motor.

→ The brakemotor is strongly recommended

THIS DOCUMENT DISPLAYS MOST TYPICAL STANDARD FEATURES AND SETUPS: CONTACT OUR OFFICES FOR MORE. ACTUATOR SHALL NOT COME TO MECHANICAL STROKE-END, TO AVOID FAILURES. CONSIDER MECVEL'S LIMITSWITCHES OR PUT THEM ON MACHINE/FRAME. BEFORE OPERATING ACTUATOR MAKE SURE YOU READ AND UNDERSTOOD BASIC OPERATIONAL INSTRUCTIONS SHOWN ON USERMANUALS, AVAILABLE FROM WEBSITE.

 MecVel reserves the right to change products information and/or features without notice; all data contained in this catalogue are purely indicative and not binding for the company.

HRS50 BELL FLANGE + COUPLING VERSION

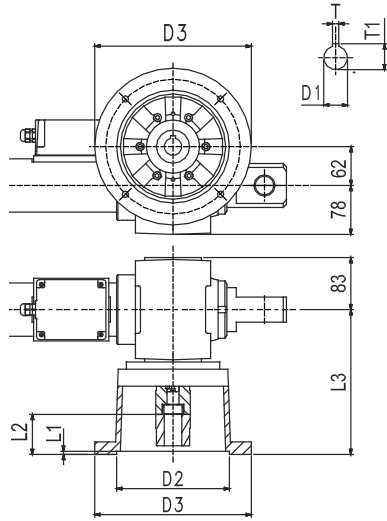

HRS50 FLANGED VERSION

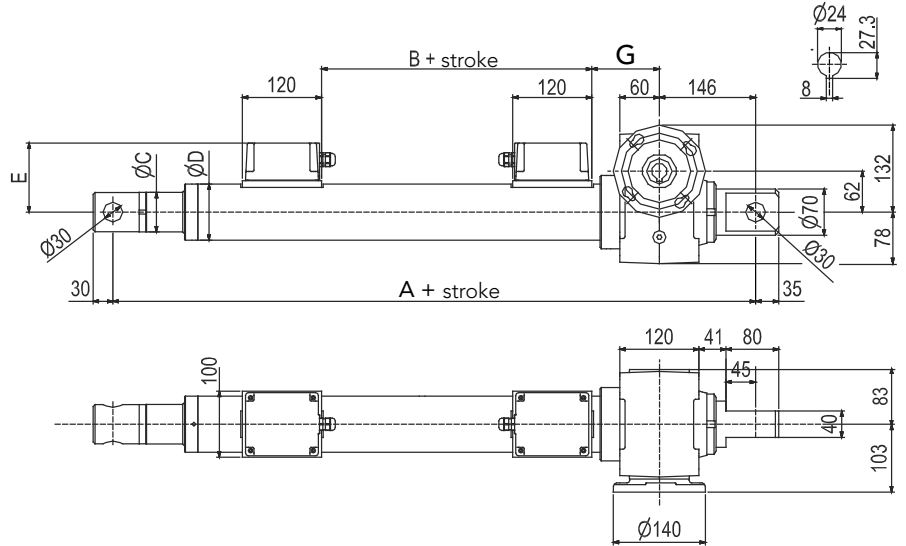

HRS50 GEARMOTOR VERSION

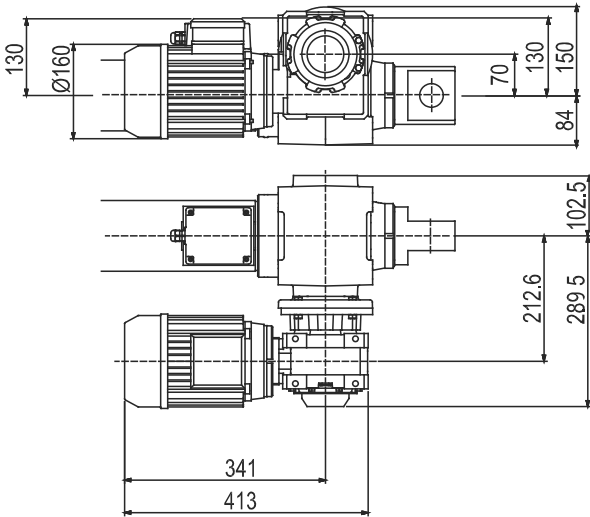

DIM.	TPN/VRS		DIM.	BELL FLANGE + COUPLING
	HRS50 TPN	HRS50 VRS		IEC 100/112 B5
A	575	715	D1	Ø 28
B	10	104	D2	Ø 180
C	60	70	D3	Ø 215
D	85	140	D4	Ø 250
E	105	132	F	Ø 14.5
G	123	161	L1	5
			L2	68
			L3	231
			T	8
			T1	31.3

HRS100 BELL FLANGE + COUPLING VERSION

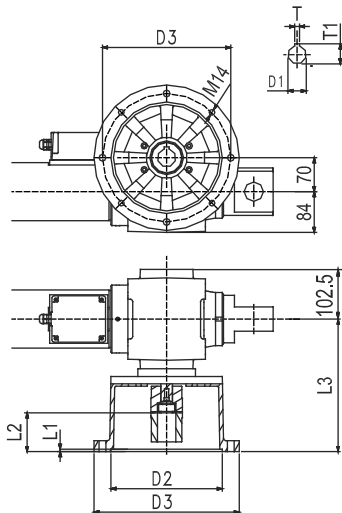

HRS100 FLANGED VERSION

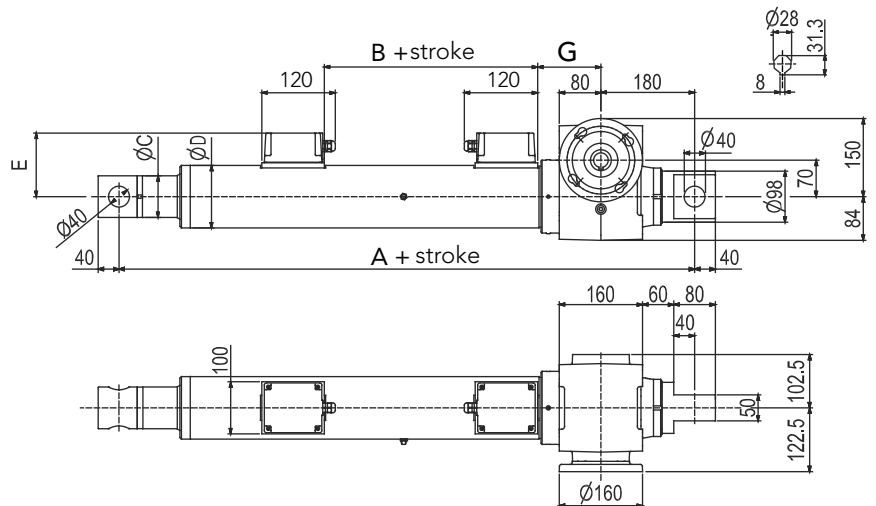

HRS100 GEARMOTOR VERSION

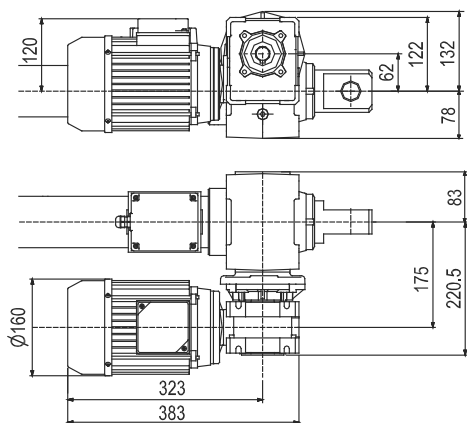

DIM.	TPN/VRS		DIM.	BELL FLANGE + COUPLING
	HRS100 TPN	HRS100 VRS		IEC 132 B5
A	706	790	D1	Ø 30
B	10	158	D2	Ø 230
C	80	80	D3	Ø 265
D	120	155	D4	Ø 300
E	122	141	F	Ø 14.5
G	152	161	L1	5
			L2	91
			L3	274
			T	10
			T1	41.3

HRS200 GEARMOTOR VERSION

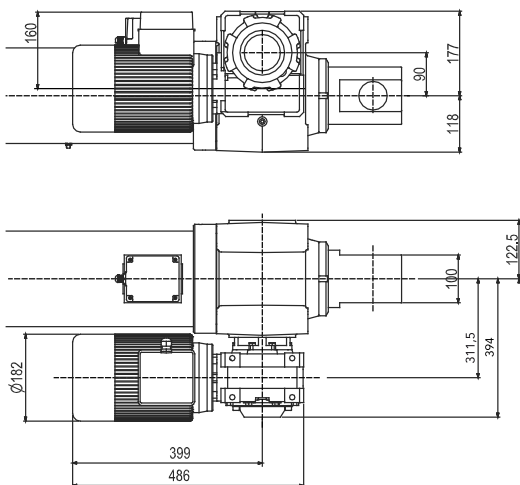

HRS200 BELL FLANGE + COUPLING VERSION

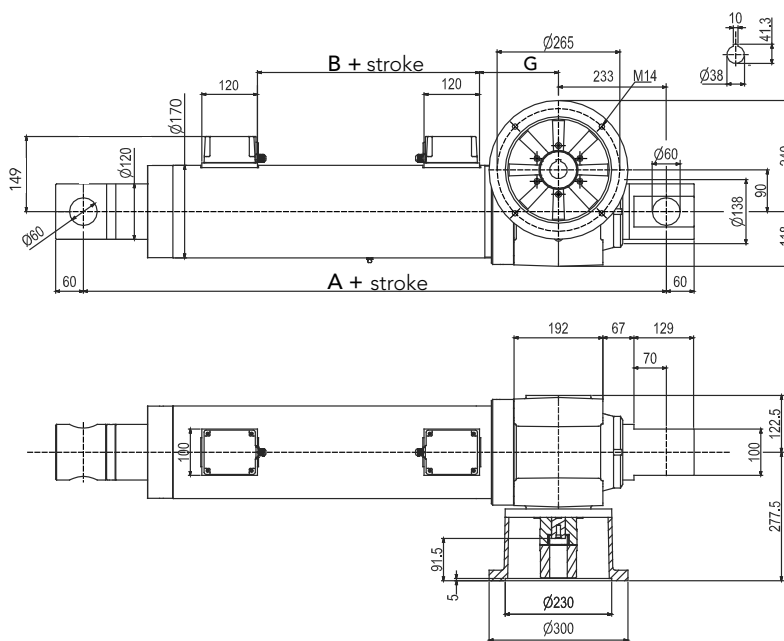

DIM.	TPN/VRS	
	HRS200 TPN	HRS200 VRS
A	880	1015
B	80	210

For motor sizes it is possible to refer to IEC standard motors.
Never allow the linear actuator to reach the mechanical stop, in order to avoid damages of internal components.

HRMS100/0250/M02/CA-400/50-T-112-4-4/AB/M0/1/E06/2FCI/P1/A1/B+L

MODEL _____
 HRS50 / HRS50 VRS / HRS100 / HRS100 VRS / HRS200 / HRS200 VRS
 with motor: indicate HRMS and the size/version required

STROKE (mm) _____
 es. 250 mm = 0250

VERSION _____
 M01 / M02 / M03 / M04 / M05
 M00 Not standard speed
 Flanged version: indicate reduction ratio and screw pitch

MOTOR _____
 AC: indicate version, tension, type, size, n. of poles, power
 with flat input motor flange indicate 0
 with specific flat input motor flange indicate PD

AC MOTOR OPTION _____
 Motorflange: for motorflange version only advise size - i.e.for IEC80 B14 put 80B14
 Protection Degree: IP65, for selfbrake motor IP54 standard
 Brake type: for brakemotors only: ES. FECA
 Options: Advise if needed (ES. AB 2'shaft)

MOTOR POSITION _____
 M0 (standard) M1 None: leave blank

E-BOX POSITION _____
 1

ENCODER _____
 Options pg.76 None: leave blank

LIMIT SWITCHES _____
 2FC1 None: leave blank

REAR END _____
 P1 eyelet (standard) P2 eyelet 90°

FRONT END _____
 A1 eyelet (standard) A3 yoke + clip A4 ball joint A7 male

OPTIONS _____
 B bellows boot L anti-rotation device T additional shaft on the opposite side of motor

FRONT END	DIM.	HRS50		HRS100		HRS200	
		TPN	VRS	TPN	VRS	TPN	VRS
A3	A	660	815	834	918	1053	1178
	B	54		72		96	
	C	30		35		50	
	D	Ø 30		Ø 35		Ø 50	
	E	55		70		96	
	F	55		70		96	
A4	A	667	818	815	900	1010	1160
	G	Ø 30		Ø 35		Ø 60	
	H	R. 35		R. 40		R. 68.5	
	I	37.5		43		44	
A7	A	531	686	669	753	838	858
	L	M 30x2		M 36x2		M 52x3	
	M	55		70		80	

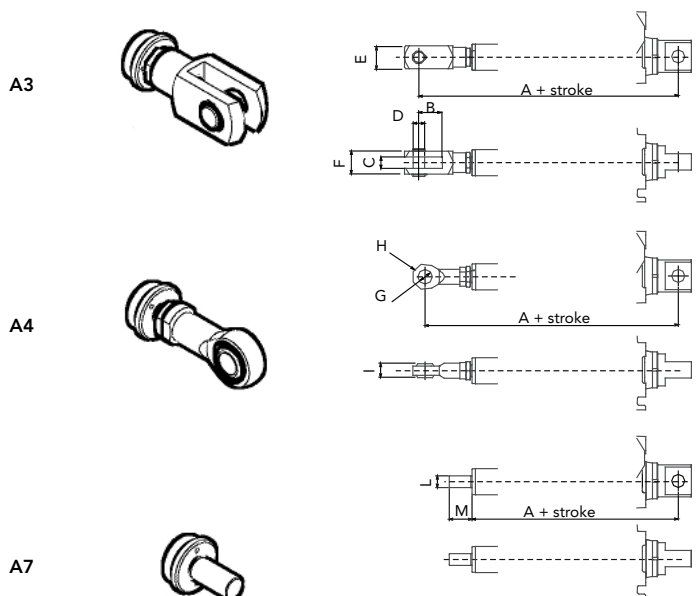

ACCESSORIES AND OPTIONS

According to the options desired, add the identification letters at the end of ordering key related to the product chosen.

A	Stainless steel
AA	Industry version
B	Bellows boot
CG	Bell flange with coupling (on request)
E	Silicon seals
FX	Anticorrosion painting
G	Safety nut
H	Handwheel
L	Anti-rotation device
MN	Manual driving for ALI1 and ALI1-P models
N	Manual driving with safety limit switch
O	Body integrated Swivelling shafts (on request)
OA	Front Swivelling plate (on request)
OP	Rear Swivelling plate (on request)
P	Handwheel and safety-switch
PO	Rear-pipe for swinging movement (on request)
S	Torque limiter
T	Additional shaft
Z	Low noise
N.DIS.	Drawing number: Request of no standard options.











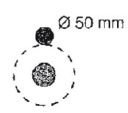

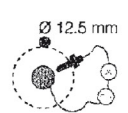

Examples:

- Ordering key for standard product
ALI5/0300/M01/CA-400-50-T-71-2-0,55/B5+AB/M0-FC1/1/E05 /2FC2/P0T01A/P1/A1
- Ordering key for standard product + options
ALI5/0300/M01/CA-400-50-T-71-2-0,55/B5+AB/M0-FC1/1/E05 /2FC2/P0T01A/P1/A1/A/B/T
- Ordering key with NO standard options
ALI5/0300/M01/CA-400-50-T-71-2-0,55/B5+AB/M0-FC1/1/E05 /2FC2/P0T01A/P1/A1/1234

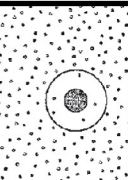
HOUSING PROTECTION LEVEL (IP CODE)

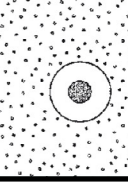
First digit Protection against solid objects

Second digit Protection against liquids

First digit	Protection against solid objects	Second digit	Protection against liquids
0	Not protected	0	Not protected
1	 Protected against solid foreign objects of 50 mm diameter and greater	1	 Protected against vertically falling water drips
2	 Protected against solid foreign objects of 12,5 mm diameter and greater	2	 Protected against vertical water drips with casing inclined up to 15°
3	 Protected against solid foreign objects of 2,5 mm diameter and greater	3	 Protected against spraying water
4	 Protected against solid foreign objects of 1,0 mm diameter and greater	4	 Protected against splashing water
5	 Protected against dust	5	 Protected against jets of water
6	 Totally protected against dust	6	 Protected against powerful jets of water jets
		7	 Protected against the effects of temporary immersion in water
		8	 Protected against the effects of continuous immersion in water

The tables shown in this page are from IEC EN 60529 (CEI 70-1) standards

MecVel standard products are equipped with IP55

MOTOR CHOICE GUIDELINE

MOTOR TYPE

VERSION	DC	direct current
	AC	alternate current
	PD	Special motorflange (provide drawing)
VOLTAGE	DC	V12 / V24
	AC	STANDARD VOLTEGE TABLE
	MT	MULTIVOLTAGE
TYPE (only for AC)	T	3-phase
	M	1-phase
	AT	3-phase with brake
	AM	1-phase with brake
SIZE	AC	IEC 50/56/63/71/80/90/100/112/132
POLE (ONLY FOR AC MOTOR)	2	
	4	
	6	

STANDARD VOLTEGE TABLE		
[V] [Hz] Rated voltages		[V] [Hz] Usable voltages
230/400/50	277/480/60	240/415/50 - 220/380/50 - 265/460/60 - 255/440/60
190/330/50	220/380/60	200/346/60 - 208/360/60 - 230/400/60
208/360/50	254/440/60	200/346/50 - 240/415/60
400/690/50	480/830/60	380/660/50 - 415/717/50

AC MOTOR OPTIONS

MOTORFLANGE	IEC56 B14 / IEC63 B14 / IEC71 B14 / IEC80 B14 / IEC90 B14 / IEC100 B14 / IEC112 B14	
SERVICE RATE	S3 30% (standard for triphse-singlephase)	
INSULATION CLASS	F standard specify when different from F	
PROTECTION DEGREE	IP54	motore standard autofrenante
	IP55	
	IP65	a richiesta
	TP	tropicalization
	AOTHER	indicate
	WITHOUT	leave blank

MOTOR CONNECTION

Triphase motor

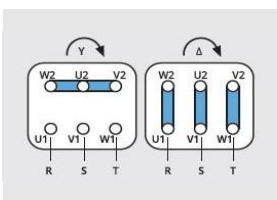

Singlephase motor (DC)

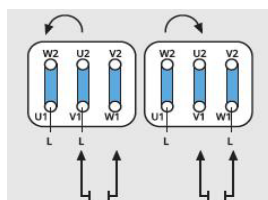

Triphase brakemotor (AC)
- With power supply

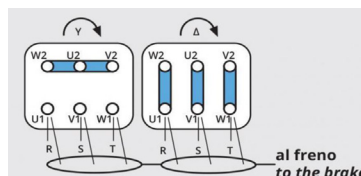

Triphase brakemotor (AC)
- Separate power supply

- A. motor terminal board
- B. auxiliary terminal board
- C. brake
- D delta connection
- E star connection

Triphase brakemotor (DC)

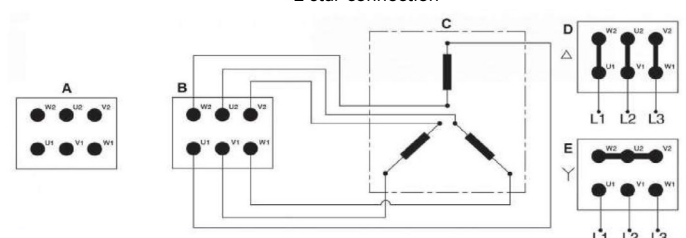
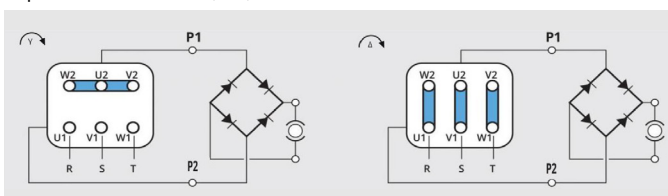

BRAKE FECC DC brake

Electromagnetic spring applied brakes for DC motors, available for single-phase and three-phase motors. Supply voltage: 230 V (single-phased) ± 10% 50/60 Hz. The brake is powered directly from the motor's power supply (standard). FECC brakes have a slower reaction time when compared to CA brakes, but are quieter.

Motors with separated brake power supplies and different tensions (24-205 Vdc) can be available, on request. In this case, the brake needs a separate power supply from the motor and its code becomes FECC-AS-24 Vdc

FECA AC brake

Electromagnetic brake for AC motors, available only for three-phase motors IEC63 model or above. Supply voltage: 230V (tree-phase) ± 10% 50/60 Hz. The brake is powered directly by the motor's power supply. FECA brakes have a quicker reaction time when compared to DC brakes, but noisier. It is suggested when multiple uses in a short period, and/or a high braking torque are required.

Motors with separated brake power supply and tensions in the range 24-690 Vac - 50/60 Hz can be available on request. In this case, the brake needs a separate power supply from the motor and its code becomes FECA-AS-230 Vac 50 HZ

Separate brake power supply: Achieved using an auxiliary terminal board, with fixed brake coil terminals, located inside the motor terminal box

Nb: For all motors equipped with inverters, the brake must always have a separate power supply.

OPTIONS	LS	hand release lever	AB	2'shaft
	OTHER	advise	NONE	leave blank

ELECTRIC / ELECTRONIC STROKE CONTROL DEVICES

Actuators can host different stroke control systems: simple micro-switches (mechanical or magnetic) able to provide a signal to handle motor supply (ON-OFF operation), or electronic devices for servo-mechanisms.

All wiring operations of actuator (motor and stroke control devices) must be done with power switched off. If not, both operator and actuator are at risk.

LIMIT SWITCHES INTEGRATED IN TO COVERTUBE (ONLY FOR ALI1 AND ALI1-P MODEL)

This model is equipped with two limit switches (featuring one contact each). A version with a third limit switch, central positioning, is available. Intermediate position changes according to push-rod moving direction. Tuning is adjusted by turning screws on actuator header. Each clock wise turn of the screw allows the micro switch to go 0.7 mm. forth, towards the header itself. Look at the drawing to see how it works; letters have following meaning:

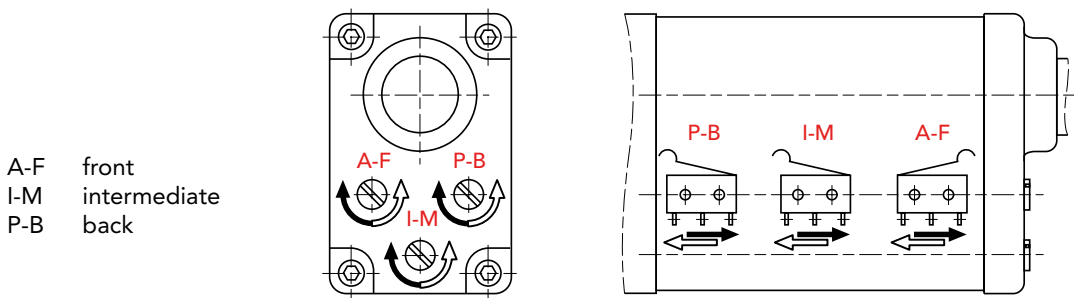

A-F front
I-M intermediate
P-B back

Limit Switches Features:

- Housing: Glass fibre reinforce PA66
- Mechanism: Snap-action coil spring mechanism with stainless steel spring. Change over, normally-closed / normally-open
- Mechanical life: 5x10⁶ cycle minimum (impact free actuation)

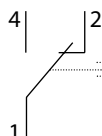

INTEGRATED MECHANICAL LIMIT SWITCHES

Changeover single-contact, cam-actuated micro-switches integrated onto actuator gearbox, getting movement by a small gearing connected to lead screw. System is thus protected and compact but its limit lies in long strokes: since the stroke is directly related to cams angle of rotation, with long strokes this device is not able to perform. Furthermore its stopping precision and repeatability are negatively affected by actuator non-self locking condition. A potentiometer is also available for some of the gearbox ratios (hence speeds) and limited lengths of the stroke to be controlled.

 In case integrated mechanical limit switches are delivered already adjusted, manual rotation of push-rod will cause adjustment loss!

 **RUNNING AGAINST MECHANICAL STOP CAUSES SERIOUS DAMAGES TO ACTUATOR'S MECHANICAL STROKE LIMIT DEVICE!**

ORDERING KEY REFERENCES:

- 2FC1 2 micro
- 3FC1 3 micro

Limit Switches Features:

- Housing: heat-sealed phenolic / melamine resin
- Mechanism: Snap-action coil spring mechanism with bronze/ beryllium spring. Change over, normally-closed / normally-open
- Mechanical life: 3×10^5 cycle minimum (impact actuation)

2FC1

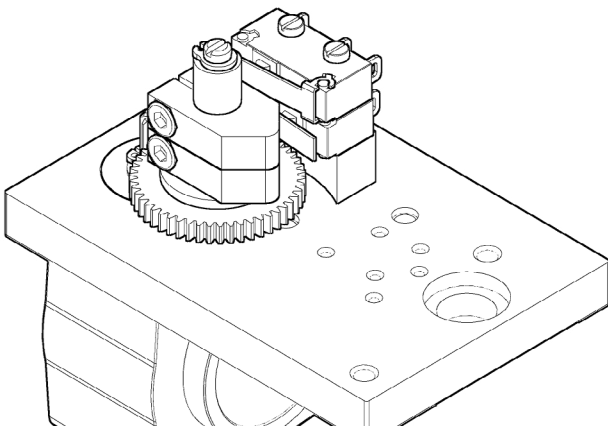

3FC1

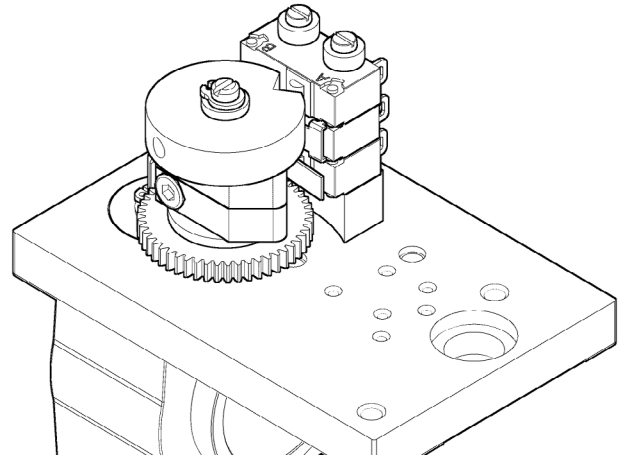

INDUCTIVE SENSORS FCI

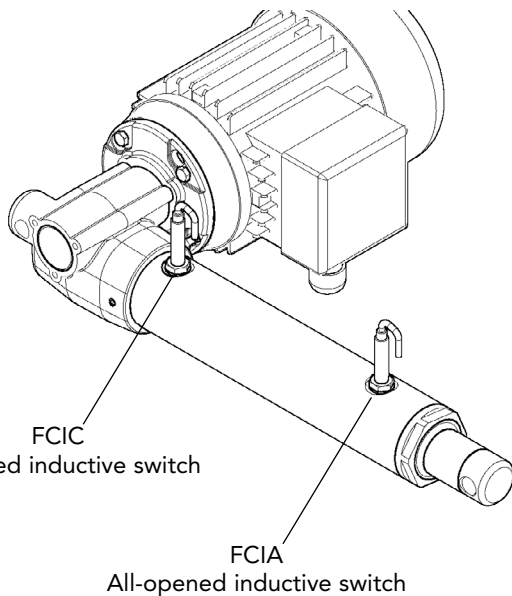

NA + NC

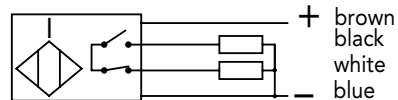

FCI INDUCTIVE LIMIT SWITCHES	
DC voltage	5 ÷ 40 Vcc
Temperature range	25° ÷ 75°
Protection level	IP67
Switch status indicator	YELLOW LED

ORDERING KEY REFERENCES

- 2FCI 2 sensors NO + NC

FCI POSITION

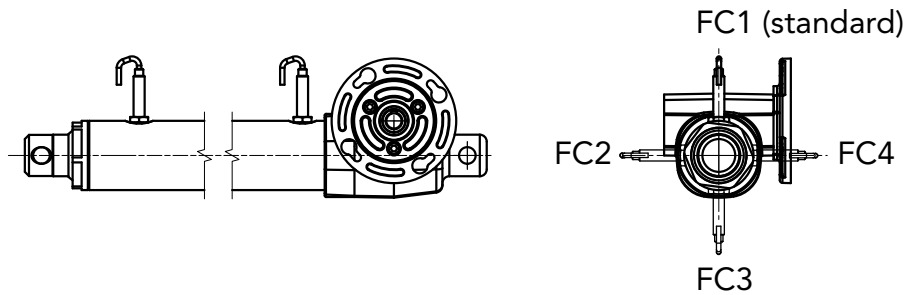

MAGNETIC LIMIT SWITCHES FCM

Magnetic sensors are activated by a magnetic field generated by a magnetic ring fixed to the nut. These reads are mounted on outer tube with brackets; outer tube shall therefore be built with non-magnetic materials.

The magnetic switches are fixed as shown in the figure, the customer can rotate at will by adjusting the bracket.

! Due to the size of the magnetic switches and to the so called switching band generated by the internal magnet the maximum working stroke is reduced by a few millimetres. This switching band width differs according to actuators size.

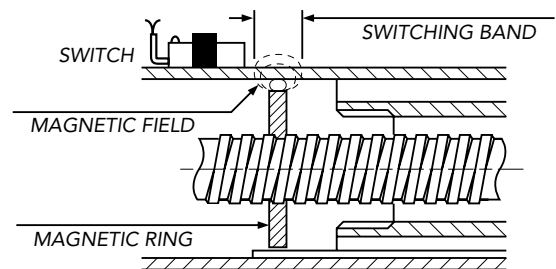
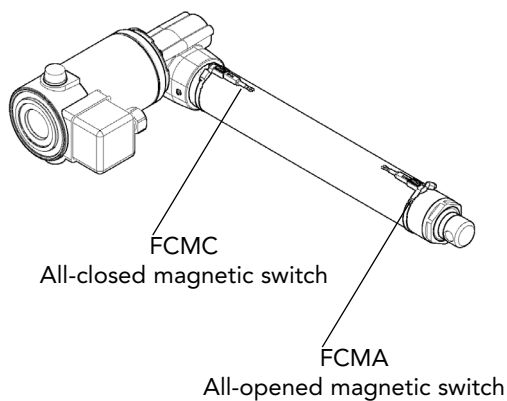

FCM MAGNETIC LIMITSWITCH			
Performance	Reed NC (standard)	Reed NO	PNP
DC voltage	5 / 130 V	5 / 130 V	5 / 30 V
AC voltage	5 / 130 V	5 / 130 V	5 / 30 V
25°C Current	200 mA	200 mA	500 mA
Power	6 W	10 W	6 W
Supply cable	PVC 2 x 0,14 mmq	PVC 2 x 0,14 mmq	PVC 3 x 0,14 mmq
Cable lenght		2000 mm	
Protection		IP67	

CIRCUIT REED NC

Circuit with normally closed Reed switch protected by a varistor against overvoltages caused when switching off, with LED indicator (image in the following page)

CIRCUIT PNP

Circuit with Hall-effect switch and PNP outlet. Protected against overvoltage spikes and reverse of polarity. With LED indicator (image in the following page)

CIRCUIT REED NO

Circuit with normally open Reed switch protected by a varistor against overvoltages caused when switching off, with LED indicator.

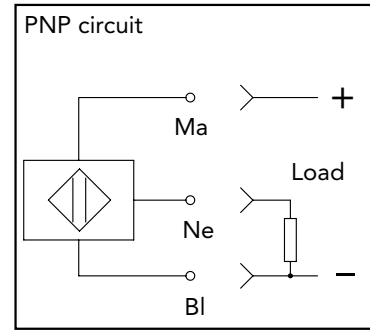
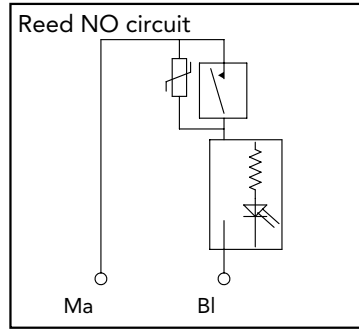
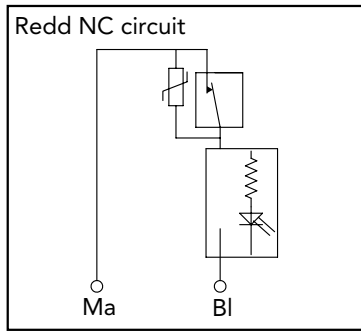

ORDERING KEY REFERENCES

- 2FCM0 2 Sensors circuit Reed NC (standard version without prior information)
- 2FCM1 2 Sensors circuit Reed NO
- 2FCM2 2 Sensors PNP

INTEGRATED LIMIT SWITCHES AND POTENTIOMETER - STROKE CONTROL DEVICES ASSEMBLY

POTENTIOMETER

Absolute feedback for actuator position monitoring; it can be installed alone or together with limit switches, so to achieve end positions control also. Potentiometer movement comes from the same gearing of the integrated limit switches therefore it has the same limit: long strokes cannot be controlled. Please refer to each actuator performance table to know max achievable length. Furthermore potentiometer electric angle cannot always be achieved. NB: not available for ALI1, ALI1-P and L series.

VERSION WITH LIMITSWITCHES AND POTENIOMETER

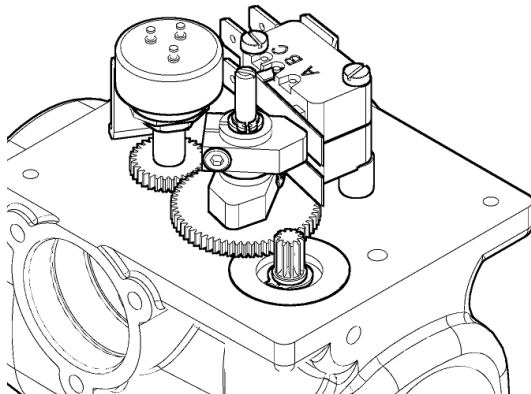

VERSION WITH POTENIOMETER

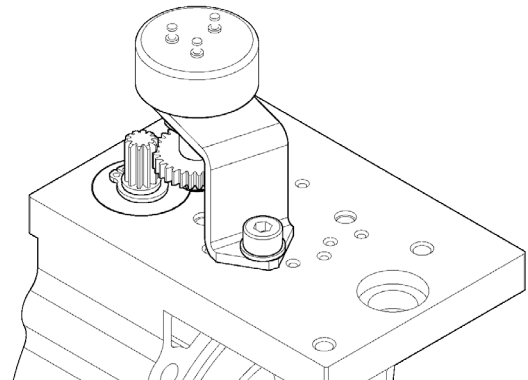

POTENTIOMETER	
Performances	Type (A)
Max. angle	340° ± 3°
Resistance	1K / 5K / 10K (standard)
Independent linearity	± 2%
Tolerance	± 20%
Coefficient of temperature resistance	± 600 ppm / °C

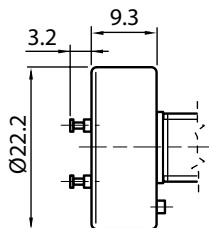
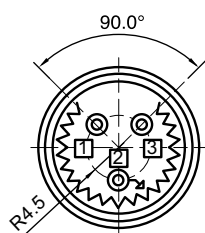

SYMBOL

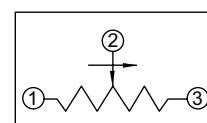

ORDERING KEY REFERENCES

- POT01A 1 kOhm
- POT05A 5 kOhm
- POT10A 10 KOhm (standard)

N.B. to be adjusted by end-user

INCREMENTAL ENCODER

An incremental rotative transducer converts spinning movement into digital pulses. It can be installed on actuator, by using a longer worm-screw extension (rotating at the same speed of the motor) and coming out from the gearbox on opposite side of motor, or directly on AC or DC motors. Its digital output allows for a relative (not absolute) feedback on actuator position, hence, every time machinery is resetted, encoder shall be given the zero position.

ENCODER ON DC MOTOR

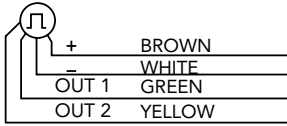
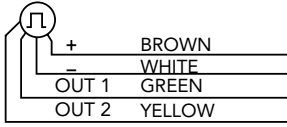
MODEL	ENCODER FEATURES	WIRING DIAGRAM	TYPE
ALI1 ALI1-P	<ul style="list-style-type: none"> Power supply 5 V - 24Vcc (+10%) PUSH-PULL 2 channel - 4 ppr square wave Max output current 20 mA + 15% for each channel 		See wiring diagram ALI1
ALI2 ALI2-P ALI3	<ul style="list-style-type: none"> Power supply 5 V - 20 Vcc NPN Open Collector 2 channel - 1 ppr square wave Max output current 100 mA 		E01
L02 L03	<ul style="list-style-type: none"> Power supply 5 V - 24 Vcc (+10%) PUSH-PULL 2 channel - 4 ppr square wave Max output current 20 mA + 15% for each channel 		E00

ENCODER MOUNTED ON AC MOTORS

- Bidirectional incremental encoder, with (standard) or without zero-pulse, protection IP54.
- Available ppr: 50 / 100 / 200 / 400 / 500 / 512 / 1000 / 1024 (standard)
- Available output circuits: Line Drive 5 Vdc (standard)/ Push Pull 24 Vdc / Open Collector NPN 10 -30 Vdc / OpenCollector PNP 10 -30 Vdc.

ORDERING KEY REFERENCES

ENCODER ON DC MOTOR

E01 NPN 2 channel ppr

ENCODER ON AC MOTOR

E05 Push Pull 1024 ppr

E06 Line Drive 1024 ppr (standard)

E07 Open Collector NPN

E08 Open Collector PNP

ENCODER ON ACTUATOR HOUSING

E00 Push Pull 2 channel 4 ppr

E09 Push Pull 1024 ppr

E10 Line Drive 1024 ppr

E11 Open Collector NPN

E12 Open Collector PNP

E13 Encoder not considered above (according to customer request)

L02 & L03

E00 Push Pull 2 channel 4 ppr

	E00	E01	E05	E06	E07	E08	E09	E10	E11	E12	E50
ALI2-CC		○									
ALI2-CA			○	○	○	○					
ALI2-P		○									
ALI3-CC		○									
ALI3-CA			○	○	○	○					
ALI4	○		○	○	○	○	○	○	○	○	
ALI4-P	○		○	○	○	○	○	○	○	○	
HP5		○									
ALI5	○		○	○	○	○	○	○	○	○	
ALI5-P			○	○	○	○					
AV3			○	○	○	○					
L02	○										
L03	○										
EC			○	○	○	○					
HRS	○		○	○	○	○	○	○	○	○	

○ : a richiesta

OPTION A - STAINLESS STEEL

The stainless steel version includes front rear and push rod in stainless steel (X5CrNi18-10). For AV3 and EC models the push rod is in double chromed.

OPTION AA - STEEL INDUSTRY VERSION

The steel industry version includes:

- Larger limit switches box
- Brass gears and cams
- Metal connectors
- Silicon seals
- Mechanical limiter with warning sensor
- Handwheel for manual driving (standard pos.N; optional P and H)
- Front end with shock absorber

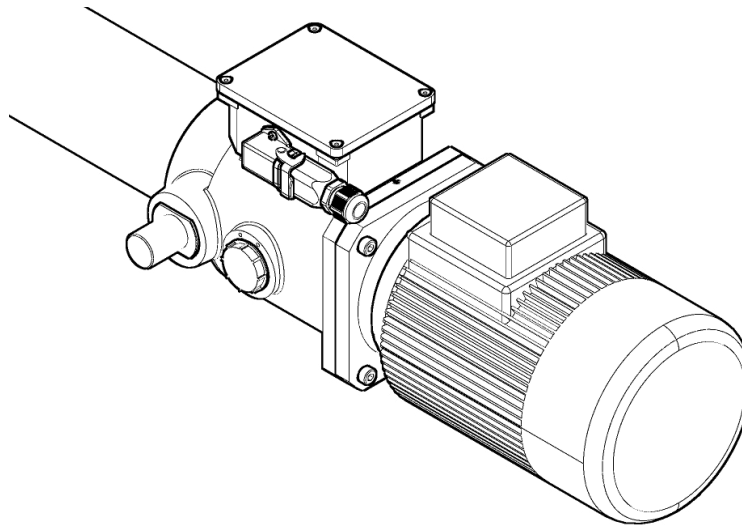

OPTION B - BELLOWS BOOT

Bellows boot protects push rods: pharmaceutical and food industries or aggressive environments are typical examples of applications where this option can be required.

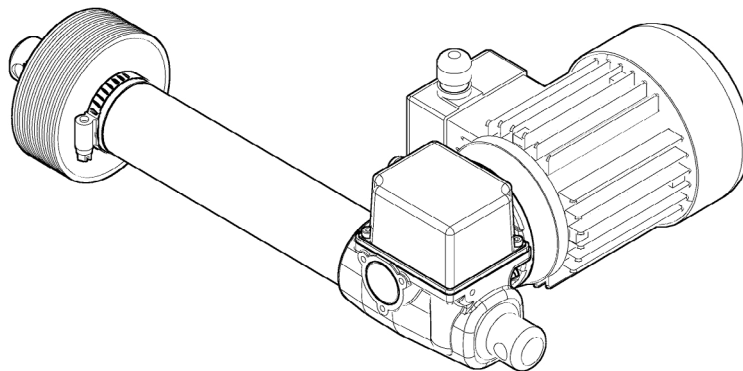

OPTION E - SILICON SEALS

Silicon seals are available as a replacement to those of NBR, except models ALI1 and ALI1-P. For actuators with Option AA (Steel industry version) Silicon seals are included.

- T NBR -30°C +110°C
 - T Silicon -50°C +200°C
-

OPTION FX - PROTECTIVE PAINTING

Anti-corrosion coating used on all metals and many other materials also against aggressive agents such extreme sea water, industrial fumes, acid rain, etc. .. It also has excellent resistance to impact and abrasion.

OPTION G - SAFETY NUT

The safety nut has been designed to start working only in case of main nut maximum wear. This safety nut is connected to the main bronze nut and travels with it along the stroke. When the bronze nut is completely worn out, the steel nut starts working on acme screw until it comes to a complete grip to acme screw. This kind of nut can work in both directions and that is integral with the load in both compression or traction (pushing / pulling)

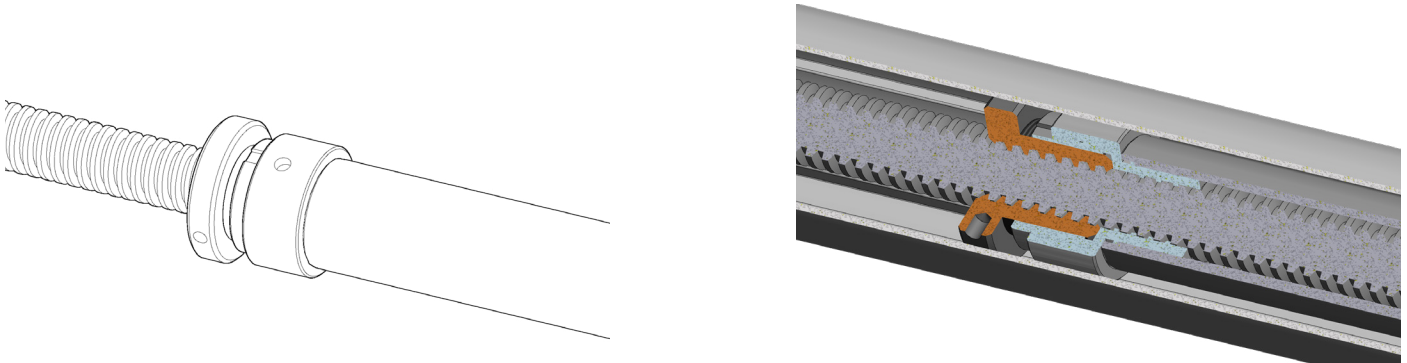

OPTION H, N, P - HANDWHEEL AND SAFETY-SWITCH UNIT

Option allowing actuator driving back in case power supply fails or some other inconvenience occurs. Second shafts on the back of the motors or extended worm-screws coming out from gearbox (see Encoder paragraph) can be manually turned with hand wheels, so to let actuator move without power supply for load disengagement. Gearing ratio and screw pitch determine number of revolutions to be done to run whole actuator's stroke: be aware that this number can be quite high.

- **OPTION H** For all model in A.C. Only for EC model with safety limit switch MS
- **OPZIONI N e P** Only for model EC With safety limit switch MS

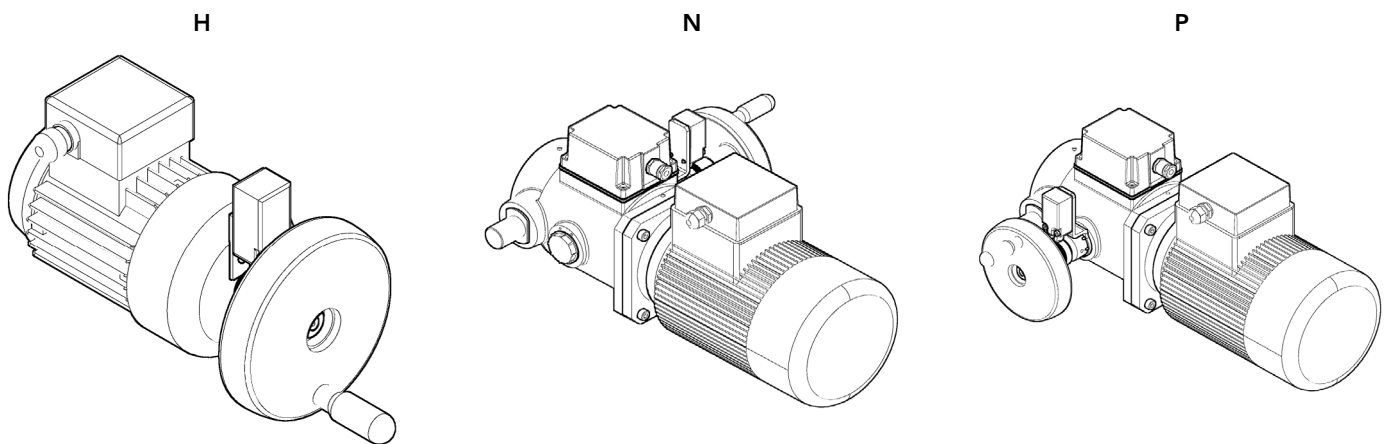

WARNING - Before connecting motor to power supply, you must connect power to safety microswitch positioned on hand wheel : so you can disconnect motor from power supply pressing safety switch and be able to work in safe conditions

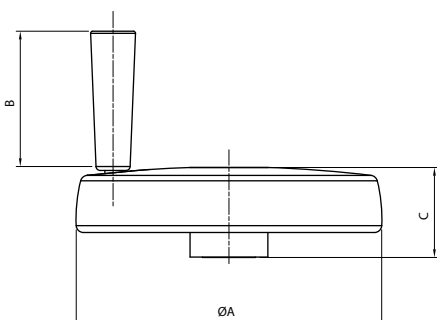

Dimensions			
Model	A	B	C
ALI2-ALI3-ALI4-ALI5-EC1-EC2-EC3-EC4	Ø 150	65	44
AV3-EC5	Ø 250	90	66

OPTION MM - MANUAL DRIVING ON ALI1 AND ALI1-P

A manual driving system is available, for emergency situations, in the ALI1 / ALI1-F and ALI1-P / ALI1-P-F models. By removing the cap support, movement can be controlled using a screwdriver. In this way the shaft of the actuator can move forward and backwards

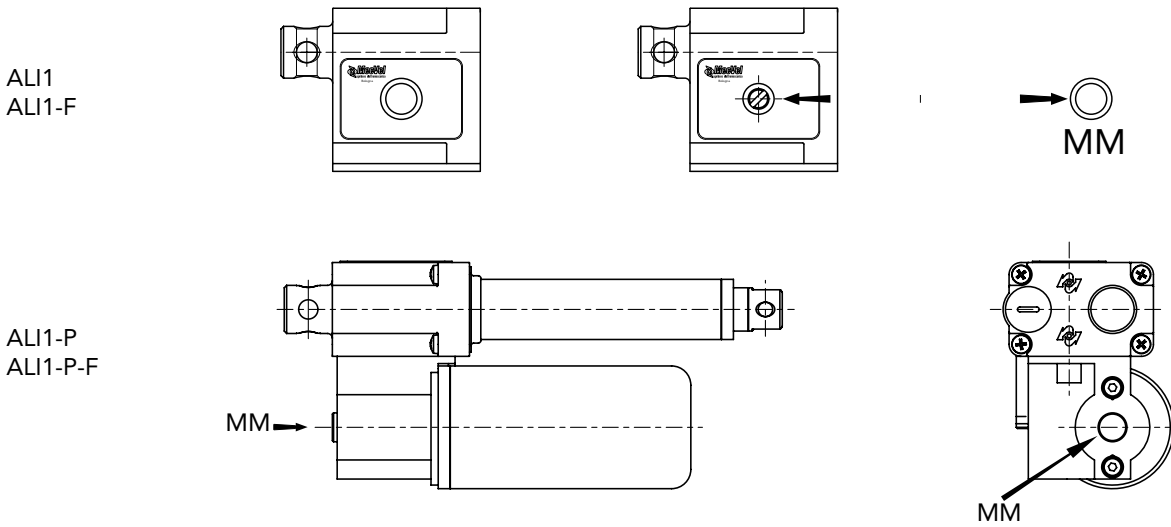

OPTION L - ANTI-ROTATION DEVICE

The Anti-rotation device avoids push rod spinning around its own axis when travelling: it is essential in case of not guided load. When the anti-rotation device is selected, the front-end is oriented to the rear-end in the assembly phase. The anti-rotation device is made in different ways depending on actuators model.

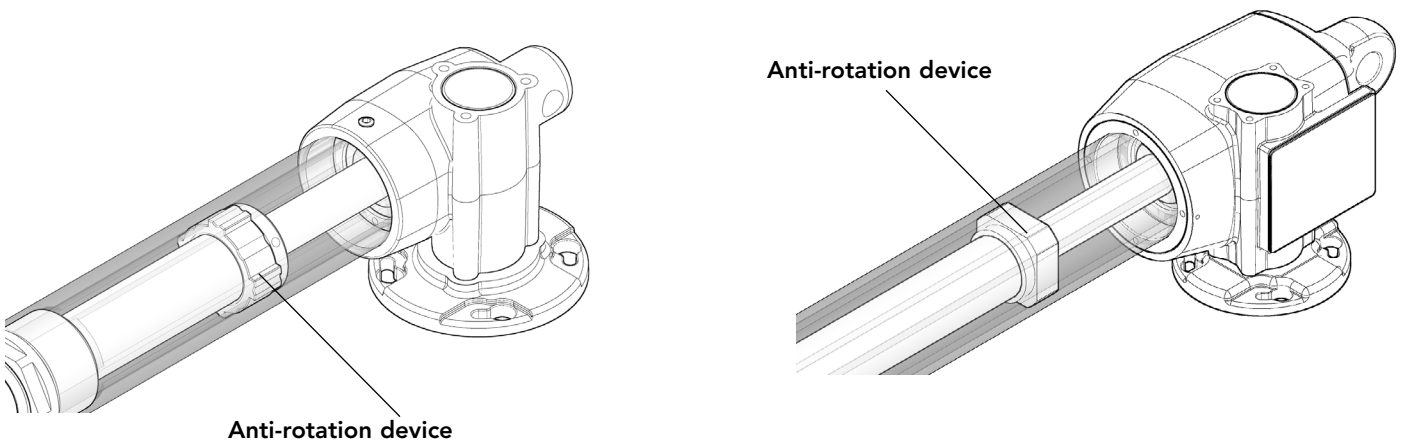

OPTION S - TORQUE LIIMTER

It is assembled between motor and gearbox to prevent occasional overload. Available for DC and AC motors with IEC flange. As to dimensions contact Technical Department.



Torque limiter reacts at 150-160% of nominal load.

Torque limiter cannot be used as stroke control device with actuator getting to mechanical end-stops. In this way you will lose the torque limiter setting and get it useless.

OPTION T - SHAFT ON MOTOR OPPOSITE SIDE (AVAILABLE ONLY ON ALI4 AND ALI5)

Shaft on motor opposite side on ALI4 e ALI4-F

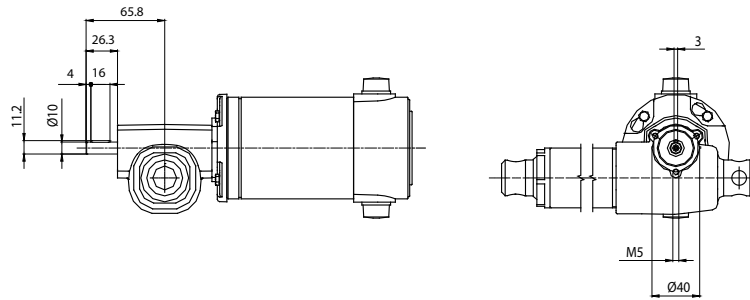

Shaft on motor opposite side on ALI5

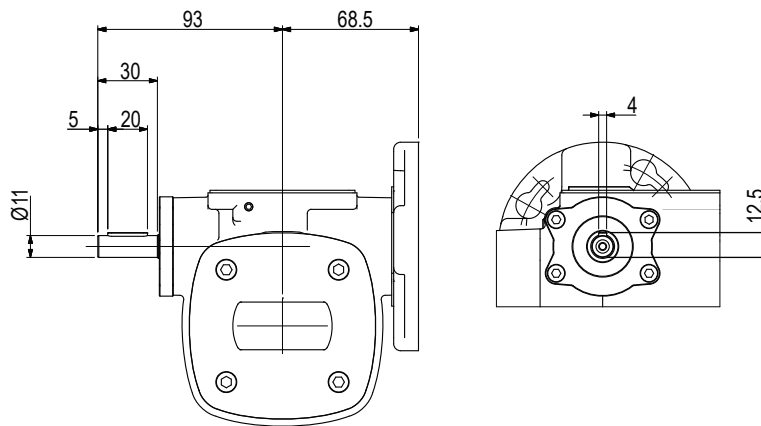

OPTION Z - LOW NOISE VERSION

It is a version with special solutions for noise reduction.

SWIVELLING SHAFTS HOLDER

To mount actuators series EC, four sizes of shaft holders.
The SP element is formed by two components.

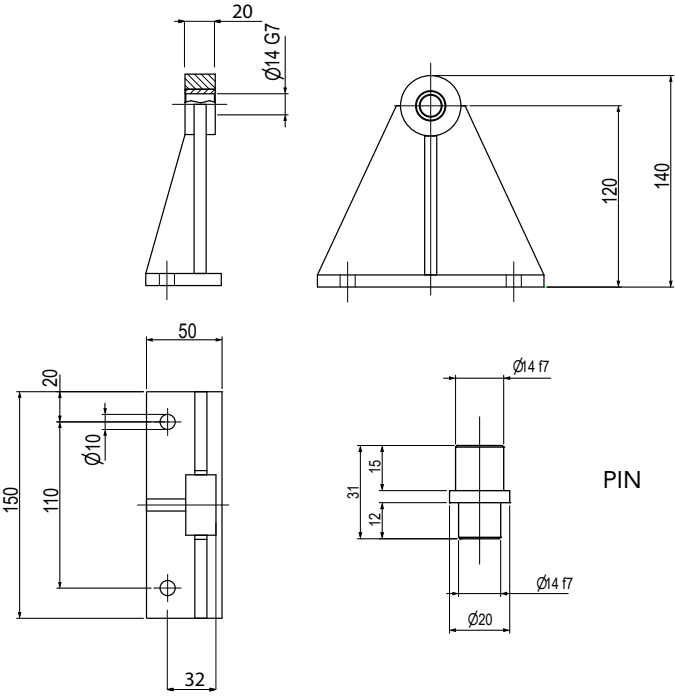
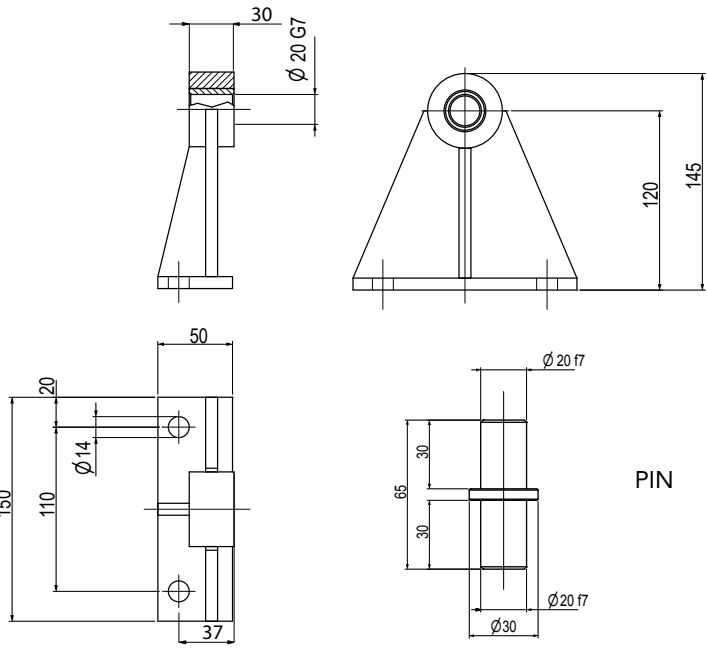
Code	Description	Dimension
SP0014	Kit of 2 shaft holders for EC1	 <p>PIN</p>
SP0020	Kit of 2 shaft holders for EC2	 <p>PIN</p>

Code	Description	Dimension
SP0030	Kit of 2 shaft holders for EC3	
SP0040	Kit of 2 shaft holders for EC4 / EC5	

BRACKET FOR FRONT AND REAR ENDS

To mount actuators having rear connection P1 / P2 and front head A1 and A4 the brackets are available for the ALI2, ALI3, ALI4 and ALI5 series.

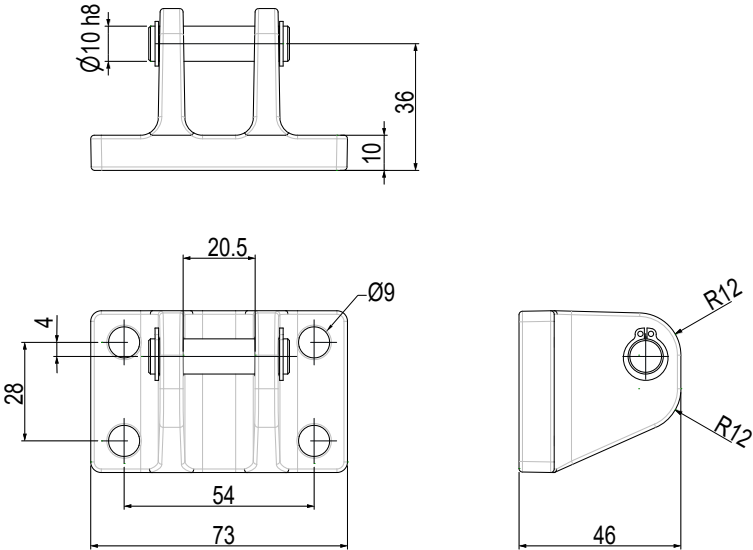
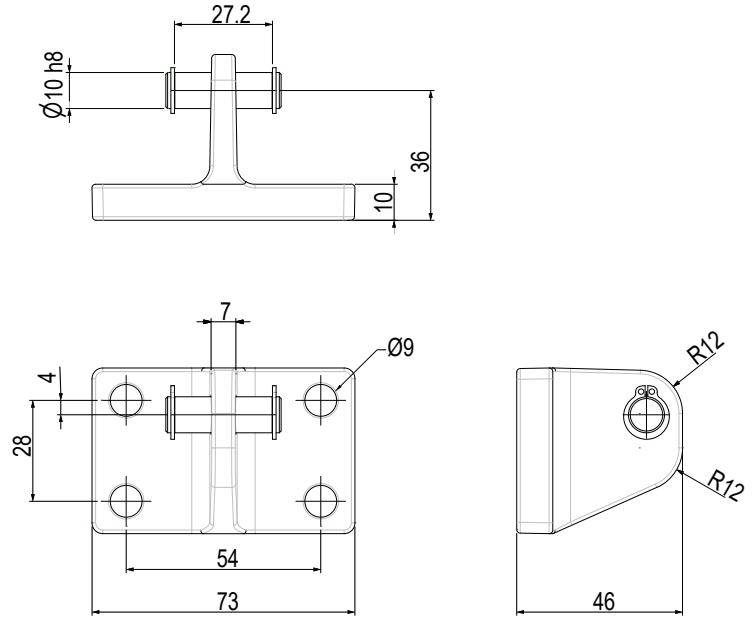
Code	Description	Dimension
SAA0002	Asymmetric bracket for front and rear ends ALI2	 <p>Technical drawing of the SAA0002 asymmetric bracket. It includes three views: a side view, a top view, and a front view. The side view shows a base with a height of 10 mm and a total height of 36 mm. The top view shows a rectangular base with a width of 73 mm and a height of 28 mm. The front view shows a base with a width of 46 mm and a height of 10 mm. The drawing also indicates a diameter of $\text{Ø}10 \text{ h}8$ for the mounting holes, a distance of 20.5 mm between the mounting holes, a distance of 4 mm from the edge to the mounting holes, a hole diameter of $\text{Ø}9$, and a radius of $R12$ for the rounded corners.</p>
SAA0003	Asymmetric bracket for front and rear ends ALI3	 <p>Technical drawing of the SAA0003 asymmetric bracket. It includes three views: a side view, a top view, and a front view. The side view shows a base with a height of 10 mm and a total height of 36 mm. The top view shows a rectangular base with a width of 73 mm and a height of 28 mm. The front view shows a base with a width of 46 mm and a height of 10 mm. The drawing also indicates a diameter of $\text{Ø}10 \text{ h}8$ for the mounting holes, a distance of 27.2 mm between the mounting holes, a distance of 4 mm from the edge to the mounting holes, a hole diameter of $\text{Ø}9$, and a radius of $R12$ for the rounded corners.</p>

Code	Description	Dimension
SAA0004	Asymmetric bracket for front and rear ends ALI4	
SAA0005	Asymmetric bracket for front and rear ends ALI5	

SALE CONDITIONS

ART. 1 APPLICABLE LAW AND CONCLUSION OF THE CONTRACT

1.1 Any matter regarding the relationship between MECVEL and the Buyer that is not explicitly or implicitly resolved by the dispositions of the present General Sales Conditions or by possible special conditions agreed upon by the parties and settled in the sale contract (that in case of contrast will be considered prevailing) will be governed by the Italian law.

1.2 Any modification to the present General Sales Conditions must be made in writing.

1.3 The sale contract (hereinafter called "contract") has to be considered as concluded when, on reception of an order, the Producer has sent an acceptance in writing within the term eventually fixed by the Buyer.

ART. 2 CHARACTERISTICS OF THE PRODUCTS AND DESCRIPTIVE DOCUMENTS

2.1 Any information relating to working characteristics of the products, weights, dimensions, abilities, prices, outputs, and other data contained in catalogues, prospectuses, circulars, advertising, illustrations or price-lists of the Producer, have character of approximate indications. These information shall be binding only to the extent they are expressly referred to in the contract.

2.2 Any design or technical document enabling the manufacture of the supplied products or their parts, that the Producer has delivered to the Buyer before or after the stipulation of the contract, remains the Producer's property, and the Buyer cannot use, copy, reproduce, transmit or communicate it to third parties without the consent of the Producer.

2.3 The title of any intellectual or industrial right related to the products is and remains of the Producer.

ART. 3 PRICE

3.1 Unless otherwise agreed the price does not include value added tax, packing, custom costs, transport and accessory expenses, and it is subject to change according to the Producer.

ART. 4 TESTING

4.1 Whether technical specifications for the tests are not specified in the contract, the tests will be carried out according to the procedures generally followed by the Producer.

4.2 If the Buyer claims for it at the moment of the order, the Producer has to communicate to him when the tests will take place, in order to allow his representatives to be present.

4.3 Unless otherwise agreed the Producer will be charged of all the expenses of the tests carried out in his establishments, in exception of those for the personnel of the Buyer.

ART. 5 PAYMENT CONDITIONS AND RETENTION OF TITLE

5.1 Payments must be made with the means and to the expiration or expirations arranged by the parties. The obligation of payment is considered fulfilled when the due amount is received from the bank of the Producer in available funds.

5.2 If the delivery occurs before the complete payment, the Products delivered remain the Producer's property until complete payment is received by the Producer.

ART. 6 INTERESTS ON DELAYED PAYMENT

6.1 In case of delay in any payment by the Buyer, the Producer can actually suspend the fulfilment of his own obligations until complete payment is effected.

6.2 In addition to what is expressed in the preceding point, the Producer will have the right to interests on delayed payment on the amount that is not paid to the agreed date, beginning from the moment in which the payment is due up to the moment in which the payment is made, previous written notice to the Buyer. The parties arrange to fix the rate of the interests on delayed payment to the.....%.

6.3 Whether the delay of the Buyer in making any payment depends on a circumstance listed under article 10, the Producer is not entitled to any interest on delayed payment.

6.4 Whether the delay of the Buyer exceeds 60 days from the agreed date, the Producer has the right to withdraw from the contract, and consequently to get from the Buyer the restitution of the products and the compensation for damages, previous written notice to the Buyer and without having to require a favourable sentence of any Court.

ART. 7 TIME OF DELIVERY

7.1 Except as otherwise agreed, the supply of goods will be Ex Works the Producer's establishment. The transfer of risks is determined in conformity to the Incoterms of the International Chamber of Commerce, in force at the moment of the contract conclusion.

7.2 Shall the delivery be delayed for any of the circumstances listed under article 10, or for any action or omission of the Buyer, a reasonable extension of the term of such delivery will be granted, considering all the circumstances of the delay.

7.3 Whether the Buyer does not withdraw the products to the agreed time, however he shall be engaged to make all the payments relating to the delivery as if the material had been delivered. The Producer shall care for the storage of the material at the Buyer's expenses and risks. On application of the Buyer the Producer has to assure the material at expenses of the Buyer.

7.4 Except if the Buyer does not withdraw the material because of one of the circumstances specified under article 10, the Producer can require the Buyer to withdraw the material within a reasonable term. Shall the Buyer, for any reason, not comply in the aforesaid term, the Producer shall have the right to withdraw from the contract, in regard to the part of the supply undelivered because of the above-mentioned breach of the Buyer, and consequently to get from the Buyer the compensation for those damages suffered because of his breach, previous written notice to the Buyer and without having to require the favourable sentence of any Court.

7.5 Possible penalties for delivery delays due to the Producer must be specified in writing at the conclusion of the sale contract, and they shall exclude any other remedy for his delayed delivery or non-delivery.

ART. 8 WARRANTY

8.1 Within the limits of the following dispositions, the Producer undertakes to remedy any imperfection that is consequence of any project, materials, or processing defect. Such obligation is limited to defects occurring during the period (hereinafter called "warranty period") of 12 months from the date of delivery to the buyer.

8.2 In order to claim the rights settled in the present article, the Buyer has to notify the Producer of all the manifested defects in writing, and he has to give him any possibility to ascertain and remedy them.

8.3 Upon reception of such notification during the warranty period, the Producer has to remedy the above mentioned defects at his own expenses. Except when the nature of the defects makes it convenient to carry out the reparation on the place, the Buyer shall forward the defective parts to the Producer, so that the latter can repair or replace them. The obligations of the Producer are considered duly carried out with the delivery to the Buyer of the repaired or replaced parts.

8.4 Except as otherwise agreed, the Buyer undertakes to bear all the costs and risks of transport of the defective parts, and the Producer those of the repaired or replaced ones, between the place where the material is located and the seat of the Producer and vice versa.

8.5 The defective products which the Producer has replaced according to the present article will be returned to the Producer within and not later than 15 days, from the date of reception of the goods sent for replacement, by the Buyer or by one of his customers on his behalf.

8.6 The liability of the Producer is limited to those defects manifesting under conditions of employment as provided in the contract and during a correct use. The guarantee does not cover defects due to causes arising after the transfer of the risks as described under clause 7.1, neither it concerns the normal deterioration.

8.7 Specially, the Buyer loses the right to the guarantee in the following cases: failure to comply with the instructions of use, installation and maintenance of the contractual products and the original spare parts, any modifications made to the products and their original spare parts without prior written consent of the Producer; any repairs made to the contractual products by persons not belonging to the Producer's network and using non-original spare parts.

ART. 9 CIVIL LIABILITY OF THE PRODUCER

9.1 Shall the Buyer or his customers modify the products or use them for purposes other than those indicated in the catalogue without having obtained prior written consent to do so from the Producer, the Producer shall not be held liable for any loss or damage caused to people or property.

9.2 Pursuant to and for the purposes of Presidential Decree no. 224/88 the Producer shall be liable for any damages caused to third parties deriving from the use of the contractual products only in the event that the injured party is able to provide unassailable proof of the existence of the damage claimed, and of the causal link between any defects and the damage.

9.3 The Producer shall not be liable in the following cases: if the defect that has caused the damage did not exist at the moment the Producer delivered the contractual products to the Buyer; if the injured party, while aware of the defect and the danger to which it might give rise, deliberately exposed itself to it; if the damage is caused by a failure to comply with the instructions set out in the manual of use and maintenance of the contractual products, or when it is caused by the use of non-original spare parts mounted on the contractual products.

9.4 The Buyer shall promptly notify the Producer of any accident or potential safety issue relating to use of the contractual products.

ART. 10 FORCE MAJEURE

10.1 Neither party shall be held in any way liable for any non-fulfilment of one of its obligations if, after the conclusion of the contract, there arise unexpectedly causes that prevent the fulfilment (such as strikes, fires, mobilisations, requisitions, embargo, monetary restrictions, riots, deficiency of means of transport, general lacks of raw materials and restrictions to the use of energy), to the extent in which it provides the proof (a) that such non-fulfilment was caused by unforeseeable events beyond its control, and (b) that at the moment of conclusion of the contract it could not reasonably foresee such event and its effects on its attitude to perform its contractual obligations, and (c) that it could not reasonably avoid or overcome such event or overcome its effects.

10.2 The party claiming for liability exemption shall notify the counterpart, as soon as possible and immediately after having discovered the impediment and its effects on its attitude to perform its obligations, of the existence of such impediment, as well as the effects of the same on its attitude to face its own obligations. Similar communication must be given as soon as the cause of liability exemption fails. Failure by the breaching party in giving such communication has the effect to make this party responsible for those damages that otherwise could have been avoided.

10.3 Whether the causes of liability exemption last for more than six months, each party shall have the right to terminate the contract. The parties will arrange the repartition of the expenses born up to that moment for the execution of the contract.

Art. 11 JURISDICTION

11.1 Any matter arising from the present General Sales Conditions and from the single sale contracts governed by them, shall be of exclusive competence of the Court of Bologna. However, as an exception to the above mentioned principle, the Producer is in any case entitled to bring his action before the competent court of the place where the Buyer has his registered seat.

MecVel[®]

Via Due Portoni 23,
40132 Bologna (IT)
tel: +390514143737
info@mecvel.com
www.mecvel.com



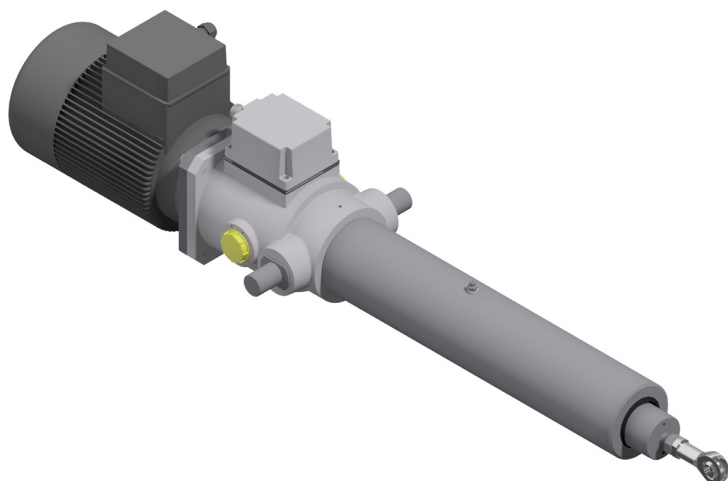

- AC motor, flange B14
- Planetary gearbox
- Acme lead screw or ballscrew (VRS)
- Chrome plated steel push rod
- Grease Lubricated
- IP55, ttested according to rule CEI EN 60529
NB: Only for brake motors Standard IP54, IP65 on request
- Working temperature range -10°C +60°C
- Intermittent duty S3 30% (5 min) a 30°C - for any other request contact MecVel technical dept.
- Integrated Limit switches for standard
- Potentiometer and encoder on request
- At-Ex II 3 D T4 version (A.C.motor) on request

EC1 (Vac)				
Fmax (N)	Speed (mm/s)	Version	Motor size	Motor power (KW)
500 *	193	M01	IEC63	0.37 2 poles
1250 *	97	M02	IEC71	0.37 4 poles
2000 *	60	M03	IEC71	0.37 6 poles
5000	24	M04	IEC71	0.55 4 poles
5000	15	M05	IEC71	0.25 6 poles
5000	6	M06	IEC63	0.13 4 poles
EC2 (Vac)				
Fmax (N)	Speed (mm/s)	Version	Motor size	Motor power (KW)
1000 *	193	M01	IEC80	0.75 2 poles
2500 *	97	M02	IEC80	0.75 4 poles
2500 *	60	M03	IEC80	0.55 6 poles
10000	24	M04	IEC80	1.1 4 poles
10000	15	M05	IEC80	0.55 6 poles
10000	6	M06	IEC71	0.25 4 poles
EC3 (Vac)				
Fmax (N)	Speed (mm/s)	Version	Motor size	Motor power (KW)
2500 *	193	M01	IEC90	2.2 2 poles
5000 *	97	M02	IEC90	1.8 4 poles
5000 *	60	M03	IEC90	1.1 6 poles
15000	24	M04	IEC90	1.8 4 poles
15000	15	M05	IEC90	1.1 6 poles
15000	6	M06	IEC71	0.37 4 poles
EC4 (Vac)				
Fmax (N)	Speed (mm/s)	Version	Motor size	Motor power (KW)
15000 *	56	M01	IEC112	2.2 6 poles
25000 *	42	M02	IEC100	4 4 poles
30000	25	M03	IEC112	3 6 poles
30000	10	M04	IEC90	1.5 4 poles
EC5 (Vac)				
Fmax (N)	Speed (mm/s)	Version	Motor size	Motor power (KW)
50000	11	M01	IEC100	3 4 poles
50000	7	M02	IEC100	2.2 6 poles

EC1 VRS (ballscrew) (Vac)				
Fmax (N)	Speed (mm/s)	Version	Motor size	Motor power (KW)
500 *	230	M01	IEC63	0.18 2 poles
1250 *	115	M02	IEC63	0.18 4 poles
2000 *	75	M03	IEC71	0.18 6 poles
5000	30	M04	IEC63	0.18 4 poles
5000	19	M05	IEC71	0.18 6 poles
5000	7	M06	IEC63	0.13 4 poles
EC2 VRS (ballscrew) (Vac)				
Fmax (N)	Speed (mm/s)	Version	Motor size	Motor power (KW)
1250 *	230	M01	IEC71	0.37 4 poles
2500 *	150	M02	IEC80	0.55 6 poles
5000 *	60	M03	IEC71	0.37 4 poles
10000 *	35	M04	IEC80	0.55 6 poles
10000	15	M05	IEC63	0.18 4 poles
EC3 VRS (ballscrew) (Vac)				
Fmax (N)	Speed (mm/s)	Version	Motor size	Motor power (KW)
3000 *	230	M01	IEC80	0.75 4 poles
3000 *	150	M02	IEC80	0.55 6 poles
10000 *	60	M03	IEC80	0.75 4 poles
15000 *	35	M04	IEC80	0.75 6 poles
15000	15	M05	IEC71	0.37 4 poles
EC4 VRS (ballscrew) (Vac)				
Fmax (N)	Speed (mm/s)	Version	Motor size	Motor power (KW)
25000 *	60	M01	IEC90	1.8 4 poles
30000 *	35	M02	IEC100	1.5 6 poles
30000	15	M03	IEC90	1.1 4 poles
EC5 VRS (ballscrew) (Vac)				
Fmax (N)	Speed (mm/s)	Version	Motor size	Motor power (KW)
50000	15	M01	IEC90	1.1 4 poles
50000	10	M02	IEC90	0.75 6 poles

* When speed is more than 30 mm/s and/or strokes longer than 350mm, check STROKE SETUP section.

With single-phase motors type M (see in paragraph ACCESSORIES) performances are 20% lower than the three-phase motor.

→ The brakemotor is strongly recommended

BEFORE OPERATING ACTUATOR MAKE SURE YOU READ AND UNDERSTOOD BASIC OPERATIONAL INSTRUCTIONS SHOWN ON USERMANUALS, AVAILABLE FROM WEBSITE. THIS DOCUMENT DISPLAYS MOST TYPICAL STANDARD FEATURES AND SETUPS: CONTACT OUR OFFICES FOR MORE. ACTUATOR SHALL NOT COME TO MECHANICAL STROKE-END, TO AVOID FAILURES. CONSIDER MECVEL'S LIMITSWITCHES (MODEL EC or EC-F) OR PUT THEM ON MACHINE/FRAME.

MecVel reserves the right to change products information and/or features without notice; all data contained in this catalogue are purely indicative and not binding for the company.

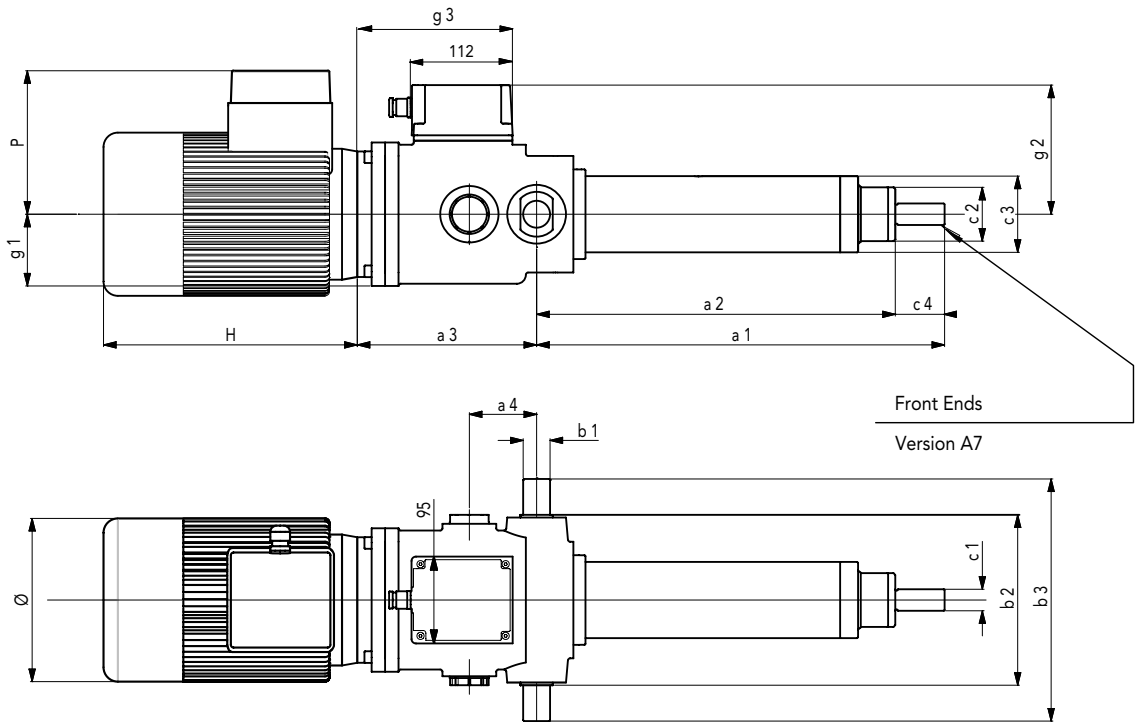

SIZE	DIMENSIONS TABLE													
	1)	1)	2)		(Øh7)								2)	
	a1	a2	a3	a4	b1	b2	b3	c1	c2	c3	c4	g1	g2	g3
1	145	111	*	61	Ø14	105	145	M10	Ø30	Ø50	34	50	103	*
2	167	123	*	66	Ø20	140	200	M12	Ø50	Ø70	44	65	118	*
3	255	200	*	75	Ø30	190	270	M18	Ø60	Ø85	55	80	138	*

SIZE	BALLSCREW DIMENSIONS TABLE													
	1)	1)	2)		(Øh7)								2)	
	a1	a2	a3	a4	b1	b2	b3	c1	c2	c3	c4	g1	g2	g3
1	169	135	*	61	Ø14	105	145	M10	Ø30	Ø50	30	50	103	*
2	233	189	*	66	Ø20	140	200	M12	Ø50	Ø70	35	65	118	*
3	317	262	*	75	Ø30	190	270	M18	Ø60	Ø85	45	80	138	*

- 1) Dimensions are valid for stroke = 0, for the exact overall dimension add the wanted stroke in mm.
- 2) Dimensions change according to actuator model. (see charts sideways)

AC MOTORS DIMENSIONS				
SIZE	VERSIONE / TYPE	H	Ø	P
63	Standard	185	123	110
	Brake motors	234		
71	Standard	215	140	121
	Brake motors	267		
80	Standard	238	159	138
	Brake motors	296		
90	Standard	255	176	149
	Brake motors	319		

EC1	Version					
	M01	M02	M03	M04	M05	M06
	a3	147	157	157	157	157
g3	131	141	141	141	141	156

EC1-VRS	Version					
	M01	M02	M03	M04	M05	M06
	a3	147	147	157	147	157
g3	131	131	141	131	141	156

EC2	Version					
	M01	M02	M03	M04	M05	M06
	a3	182	182	182	182	182
g3	158	158	158	158	158	177

EC2-VRS	Version				
	M01	M02	M03	M04	M05
	a3	169	182	169	182
g3	145	158	145	158	177

EC3	Version					
	M01	M02	M03	M04	M05	M06
	a3	200	200	200	200	200
g3	173	173	173	173	173	199

EC3-VRS	Version				
	M01	M02	M03	M04	M05
	a3	188	188	188	188
g3	161	161	161	161	199

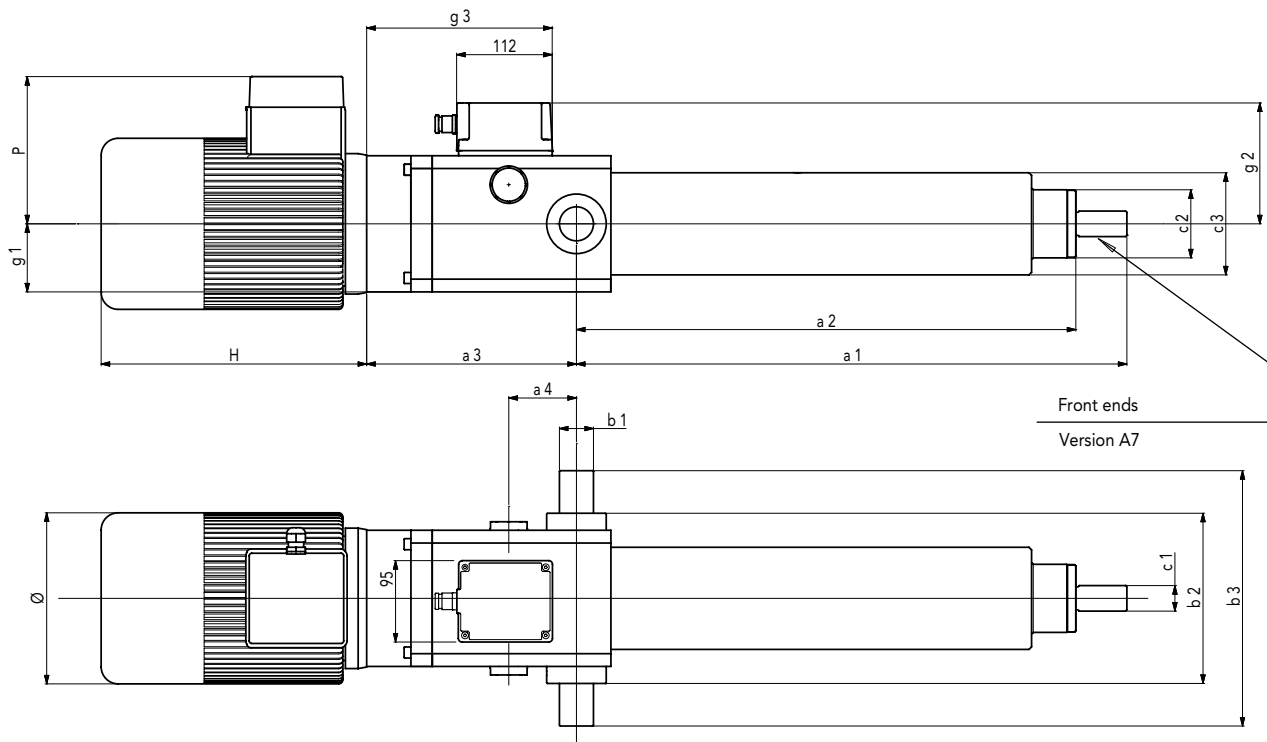

SIZE	DIMENSIONS TABLE													
	1) a1	1) a2	2) a3	a4	$\varnothing h7$ b1	b2	b3	c1	c2	c3	c4	g1	g2	2) g3
4	272	212	*	79.5	40	200	300	M30x2	80	120	60	80	136	*
5	272	212	*	79.5	40	200	300	M30x2	80	120	60	80	136	*

SIZE	BALLSCREW DIMENSIONS TABLE													
	1) a1	1) a2	2) a3	a4	$\varnothing h7$ b1	b2	b3	c1	c2	c3	c4	g1	g2	2) g3
4	318	259	*	79.5	40	200	300	M30x2	80	120	60	80	136	*
5	318	259	*	79.5	40	200	300	M30x2	80	120	60	80	136	*

1) Dimensions are valid for stroke = 0, for the exact overall dimension add the wanted stroke in mm.

2) Dimensions change according to actuator model. (see charts sideways)

AC MOTORS DIMENSIONS				
SIZE	TYPE	H	\varnothing	P
90	Standard	255	176	149
	Brake motors	319		
100	Standard	309	195	173
	Brake motors	374		
112	Standard	328	219	192
	Brake motors	407		

EC4	Version			
	M01	M02	M03	M04
	a3	246.5	246.5	246.5
g3	218	218	218	210

EC4-VRS	Version		
	M01	M02	M03
	a3	200.5	246.5
g3	172	218	210

EC5	Version	
	M01	M02
	a3	284.5
g3	256	256

EC5-VRS	Version	
	M01	M02
	a3	238.5
g3	210	210

A3 = YOKE WITH CLIP DIN 71752 / UNI 1676

SIZE	DIMENSIONS TABLE									
	a1	a1 VRS (BALLSCREW)	a2	a3	a4	a5	a6	a8	a9	a10
1	172	196	14	Ø12	M12	12	61	24	24	24
2	220	286	25	Ø20	M20x1,5	20	97	40	40	40
3	317	379	35	Ø25	M24x2	25	117	50	50	50
4 / 5	345	392	38	Ø30	M27x2	30	131	54	55	55

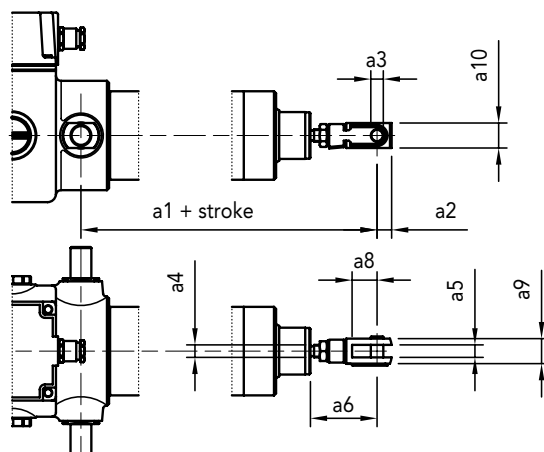

A4 = ROD END DIN 648 serie K / UNI 6126

SIZE	DIMENSIONS TABLE								
	b1	b1 VRS (BALLSCREW)	b2	b3 (ØH7)	b4	b5	b6	b7	b9
1	174	198	16	Ø12	M12	12	16	63	32
2	217	283	25	Ø20	M20x1,5	18	25	94	50
3	313	375	30	Ø25	M24x2	22	31	113	60
4 / 5	345	392	35	Ø30	M27x2	25	37	131	70

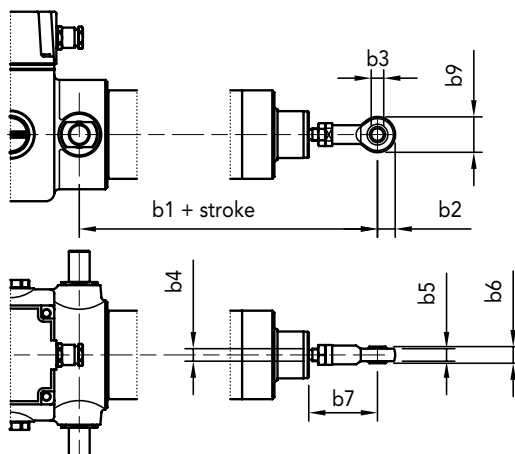

STROKE SETUP

Useful tips for handling stroke and avoid run-on-block collision.

- When stroke is more than 350 mm, add 50 mm extra-stroke as guidance, and put corresponding value in ordering-key.
- **WARNING SPEED-TIMING ALONG STROKELENGTH:** ramps are extremely important when speed is >30 mm/s!!! Inverter or PWM drive recommended!
- The more speed raises the more extra stroke has to raise too.

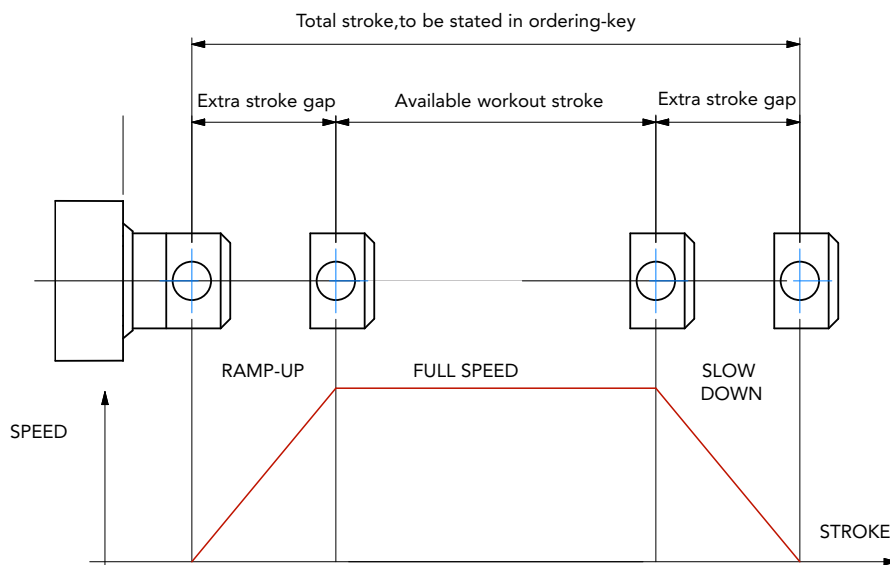

BUCKLING

When stroke is longer than 500mm, BUCKLING can be a risk: please check mounting with our offices and/or see usermanuals.

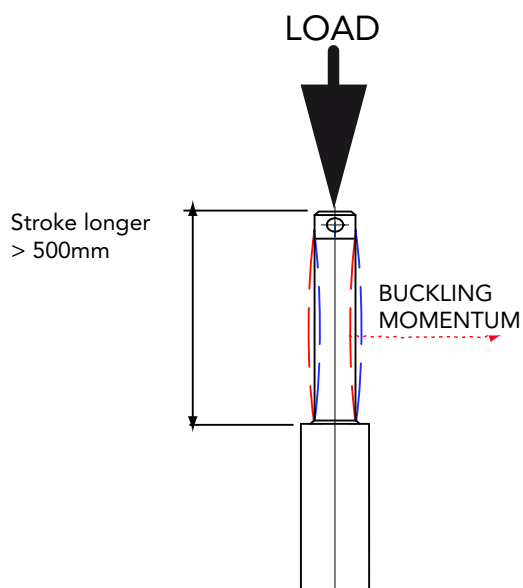

IMPORTANT: Long strokes, even if load is low, can generate significant buckling momentums, as sketch slows. This happens when actuator is in its all-opened position: that's the reason why we recommend 100 mm extra-stroke. Pushtube will have this 100 mm-portion always inside the overtube, improving guidance against buckling.

For more information on this, contact our office.

EC3/0250/M06/CA-400/50-T-71-4-0,37/AB/E06/2FC1/POT01A/A3/

MODEL

EC1 / EC2 / EC3 / EC4 / EC5
 EC1-VRS / EC2-VRS / EC3-VRS / EC4-VRS / EC5-VRS

STROKE

es. 250 mm = 0250

VERSION

M01 / M02 / M03 / M04 / M05 / M06
 M00 = Not standard speed
 Flanged Version: indicate reduction ratio and screw pitch

MOTOR

Advise only if with motor: version, voltage, type, size, n°pole, power
 With motorflange only put 0
 With special motorflange put: PD

AC MOTOR OPTIONS

Motorflange: for motorflange version only advise size - i.e.for IEC80 B14 put 80B14
 Protection Degree: IP65, for selfbrake motor IP54 standard
 Brake type: for brakemotors only (es. FECA)
 Options: Advise if needed (es. AB 2'shaft)

ENCODER

Options pg.76 None: Leave blank

LIMIT SWITCHES

2FC1

POTENTIOMETER

POT01A (1Kohm) POT10A (10Kohm) None: Leave blank

FRONT END

A3 = Yoke + Clip A4 = Rod end A7 = Male threaded pin

NOTE: COMPLETE THE ORDERING KEY ADDING THE OPTIONS YOU CAN FIND IN THE "ACCESSORIES AND OPTIONS" SECTION

