

**SCREWJACKS  
BEVELGEARS  
SHAFTS AND  
COUPLINGS**

**TECHNICAL CATALOGUE**

***MecVel***<sup>®</sup>



This page is intentionally left blank.

CERTIFICAT

CERTIFICADO

СЕРТИФИКАТ

認證證書

CERTIFICATE

ZERTIFIKAT



Italia

# CERTIFICATO

Nr. 50 100 15736 Rev.001

SI ATTESTA CHE / THIS IS TO CERTIFY THAT

IL SISTEMA DI GESTIONE PER LA QUALITÀ DI  
THE QUALITY MANAGEMENT SYSTEM OF

**MECVEL S.r.l.**

SEDE LEGALE E OPERATIVA:  
REGISTERED OFFICE AND OPERATIONAL SITE:

**VIA DUE PORTONI 23  
IT - 40132 BOLOGNA (BO)**

È CONFORME AI REQUISITI DELLA NORMA  
HAS BEEN FOUND TO COMPLY WITH THE REQUIREMENTS OF

**UNI EN ISO 9001:2015**

QUESTO CERTIFICATO È VALIDO PER IL SEGUENTE CAMPO DI APPLICAZIONE  
THIS CERTIFICATE IS VALID FOR THE FOLLOWING SCOPE OF APPLICATION

**Progettazione, produzione, vendita e assistenza di attuatori lineari  
meccanici e martinetti (IAF 17, 19)**

**Design, production, sale and assistance of mechanical linear actuator  
and screw jacks (IAF 17, 19)**



SGQ N° 049A

Membro degli Accordi di Mutuo Riconoscimento  
EA, IAF e ILAC  
Signatory of EA, IAF and ILAC Mutual  
Recognition Agreements

Per l'Organismo di Certificazione  
For the Certification Body  
**TÜV Italia S.r.l.**

Validità / Validity

Dal / From: **2021-10-25**

Al / To: **2024-05-20**

*Francesco Scarlata*

**Francesco Scarlata**

Direttore Divisione Business Assurance  
Business Assurance Division Manager

Data emissione /  
Issuing Date

**2021-10-25**

**"PRIMA CERTIFICAZIONE / FIRST CERTIFICATION: 2018-05-21 (EMESSO DA ALTRO ODC/ ISSUED BY OTHER CB)"**

"LA VALIDITÀ DEL PRESENTE CERTIFICATO È SUBORDINATA A SORVEGLIANZA PERIODICA A 12 MESI E AL RIESAME COMPLETO DEL SISTEMA DI GESTIONE AZIENDALE CON PERIODICITÀ TRIENNALE"  
"THE VALIDITY OF THE PRESENT CERTIFICATE DEPENDS ON THE ANNUAL SURVEILLANCE EVERY 12 MONTHS AND ON THE COMPLETE REVIEW OF COMPANY'S MANAGEMENT SYSTEM AFTER THREE-YEARS"

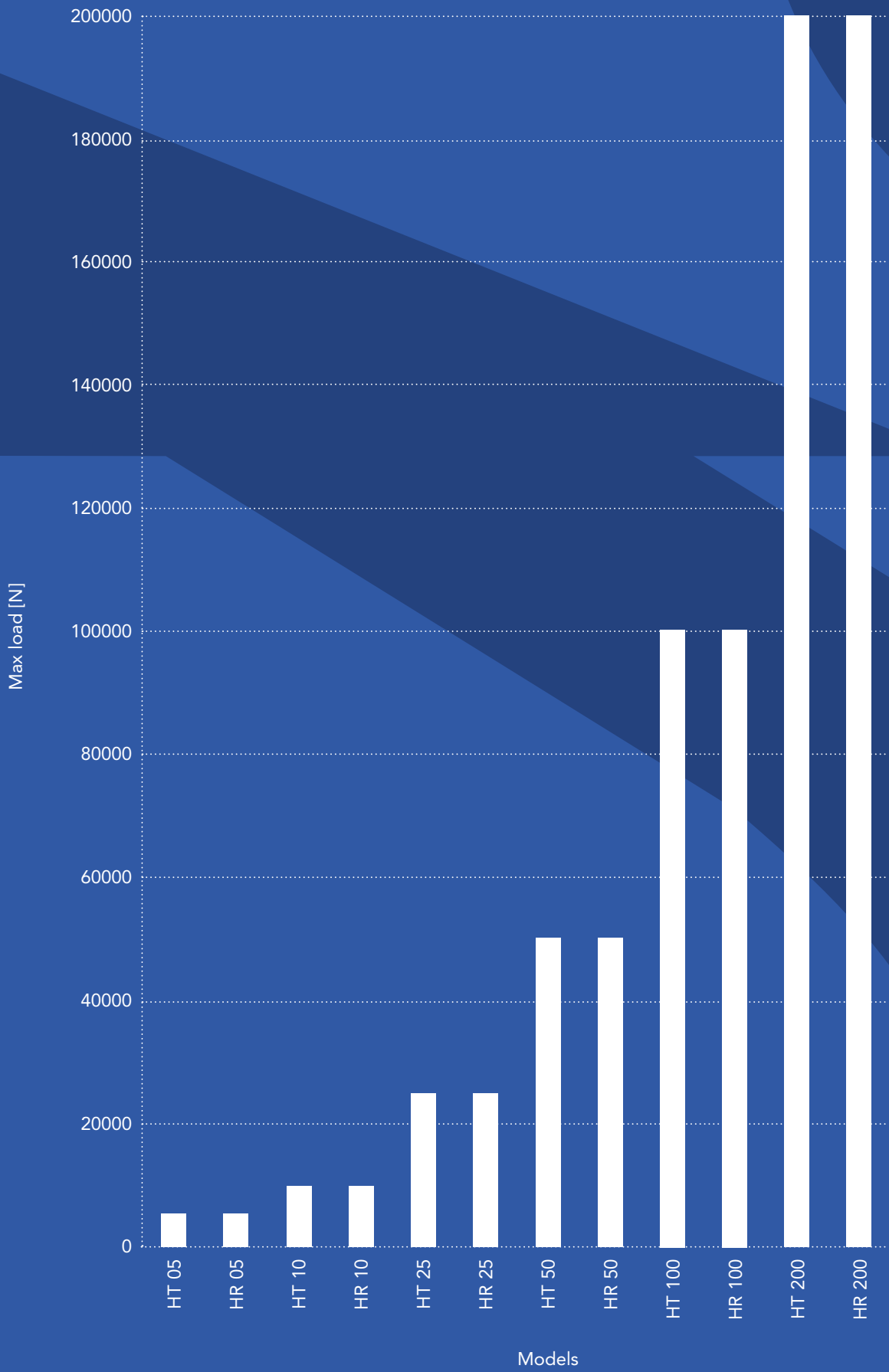

# Index

- **SELECTION GUIDELINES** ..... 6
- **HT/HR05** ..... 30
  - max load 5000 N*
  - max speed 58 mm/s*
  - AC motor*
- **HT/HR10** ..... 31
  - max load 10000 N*
  - max speed 58 mm/s*
  - AC motor*
- **HT/HR25** ..... 32
  - max load 25000 N*
  - max speed 96 mm/s*
  - AC motor*
- **HT/HR50** ..... 33
  - max load 50000 N*
  - max speed 96 mm/s*
  - AC motor*
- **HT/HR100** ..... 34
  - max load 100000 N*
  - max speed 98 mm/s*
  - AC motor*
- **HT/HR200** ..... 35
  - max load 200000 N*
  - max speed 98 mm/s*
  - AC motor*
- **OPTIONS AND ACCESSORIES** ..... 36
- **ORDINATION KEY** ..... 54
- **MODELS** ..... 55
- **COUPLINGS** ..... 56
- **SHAFTS** ..... 60
- **BEVELGEARS** ..... 64
- **GENERAL SALES CONDITIONS** ..... 69



## SCREWJACKS SELECTION GUIDELINES

### WARNINGS

Screwjacks are devices usually integrated into complex machineries, therefore can't be considered as safety devices (Art. 1 of EC89/392-91-368.93/44.93/689). Mecvel Screwjacks shall not be used as safety elements because, any failure they should provide, could harm the security and health of people.

### DESCRIPTION

Screwjack is a mechanical device providing an output linear movement by means of a spinning input movement. It can be used as a single unit, or more screwjacks can be connected via shafts transmissions and angular drives. Input rotational movement can come from a manual winding or from a motor, be that AC or DC. According to their setting and drive system, workout can simply be as "on-off" thus merely pushing-pulling a load or become servomechanisms for more hi-profile applications. Pneumatic and hydraulic cylinders do not allow for stops in intermediate positions, for example. Screwjacks can be stopped in any position of the stroke with simple devices, stroke itself can be monitored in feedback status. Energy used for motion is electricity, clean and easily available, compared for instance oil, that needs valves and pipelines. Also, oil leakage is not suitable for some kind of domains such as food, textile or pharmaceutical/medical.

### SCREWJACKS MAIN COMPONENTS

Screwjacks are made up by a wormgear system (wormscrew/wormwheel), a leadscrew and a nut. This assembly is then to be classed as a "stiff" kinematic sequence

Materials of main components:

- Aluminum gearbox for Size s 05 10 25; cast iron for Size s 50 100 200
- Hardened-tempered steel wormscrew
- Bronze wormwheel
- Nut: bronze nut
- Ball bearings
- Cast iron front lock-ring
- Aluminum rear-pipe (series "HT")
- Carbon-steel (standard) ACME leadscrew
- AISI 304-steel leadscrew
- Ballscrew: hardened-tempered steel

### GLOSSARY

Cs	duty service factor (affecting duty service)	Pi	inputpower for one jack [kW]
Ct	temperature factor	rpm	revs per minute
DX	right-handed thread for leadscrew	rpmst	max number of revolutions
F	load to be moved for one screwjack [N]	rst	critical number of revolutions [min-1]
Fe	equivalent load for one screwjack [N]	SX	left-handed thread for leadscrew
Fs	duty service	Ts	OFF-state time
Ft	total load to be moved [N]	Tf	ON-state time
Fr	radial load on shafts or wormscrew [N]	v	linear travelling speed [mm/min]
i	reduction ratio	$\mu$ m	screwjack efficiency
M	pass-through torque [Nm]	$\mu$ c	system efficiency (screwjacks, angular drives...)
Mt	input torque to screwjack [Nm]		
Mtm	motor torque [Nm]		
N	number of screwjacks and angular drives of a system		
p	ACME leadscrew / ball-screw pitch		

 **MecVel reserves the right to change products information and/or features without notice; all data contained in this catalogue are purely indicative and not binding for the company.**

## LOADS ACTING ON SCREWJACKS

Type and Size of loads are extremely important for screwjack selection. We can split these loads as follows:

- static loads
- dynamic loads

These two categories can be furtherly divided into:

- pull loads
- compression loads
- side-loads
- off-center loads
- shock loads
- loads due to vibrations

### STATIC LOAD

Load that screwjack shall bear when standing still, that is when all its components are not moving.

### DYNAMIC LOAD

Load that screwjack shall handle, when all its components are in movement (no matter which movement is, extension, retraction, pulling, pushing...).

### PULL LOADS

Pull load happens in direction opposite to screwjack gearbox. (i.e. "pulling away" from screwjack gearbox). In this case, screwjack can work at its maximum rated load.

- Static traction load: maximum rated load is allowed, but shall be re-considered in case suspect side-forces or bumping-forces should happen.
- Dynamic traction load: as for paragraph above, side-forces and bumping-forces are to be considered. But also temperature, duty factor, speed, stroke are to be carefully integrated in evaluating correct max load.

### COMPRESSION LOAD

Load happens in direction of screwjack gearbox (i.e. "pushing towards" screwjack gearbox). In this case, buckling factor gets into and therefore max load shall be limited. Buckling affects linearity of leadscrew and is generated by screw Size and length, and mounting of screwjack.

- Static compression load: admitted max load is limited by Size /length of leadscrew and mounting of screwjack. Such figure can be achieved from Euler diagrams. Furthermore, side/bumping-forces shall also be considered.
- Dynamic compression load: admitted max load is limited by Size /length of leadscrew, temperature, duty factor, side/bumping-forces. Euler diagrams shall also be considered, in addition to items seen for traction load.

### SIDE LOADS

Loads applied at 90° towards leadscrew axis. Such loads, thus, generate bending on leadscrew, and are therefore always considered as dangerous. Avoiding or at least limiting them is then mandatory. Side loads can also be originated by a mis-alignment during mounting of screwjack, i.e. leadscrew doesn't work aligned.

- Static side load: leadscrew tends to be pushed aside from its natural axis, limiting screwjacks max rating. Diagrams show max admitted side loads according to leadscrew length. Contact Mecvel offices for further and more detailed advice.
- Dynamic side load: such kind of loads is NOT ADMITTED AT ALL. In case some small dynamic side load is to be foreseen / can't be eliminated, contact Mecvel offices.



## SHOCK LOADS

Generated by shocks/bumps along stroke, whose force is rather difficult to foresee or rate.

## OFF-CENTER LOADS

Load is applied on a point not straightly in line with leadscrew axis.

- Static off-center load: see paragraph about side-loads.
- Dynamic off-center load: frame where screwjack is installed shall absorb all the side-forces/off-center forces, therefore frame shall be carefully guided and Sized to do so.

## VIBRATIONS

Generated by oscillations of kinematic sequence (of screwjack) happening after an impact. This is the main difference towards the bumping loads, i.e. the frequency. Vibrations can be assimilated to "a long series of small bumps".

- Vibration to a static load: a vibrating static load can generate BACKDRIVING of screwjack, i.e. screwjack can't hold the load in position when stopped. Contact Mecvel offices for further analysis.
- Vibration to a dynamic load: this kind of load is extremely dangerous, because it speeds up wear of components (leadscrew-nut especially). In this case, vibrations shall be eliminated or at least strongly limited. Contact Mecvel offices in order to evaluate more in depth how to Size screwjack.

Explicative figures on loads on the next page.



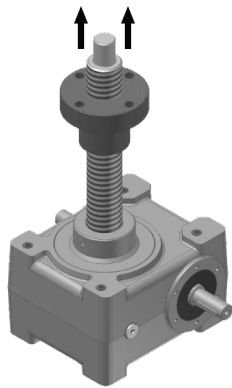

Pull load

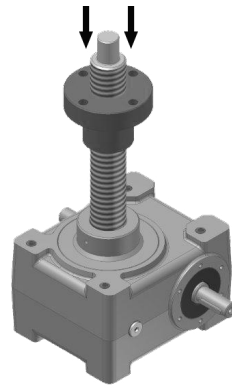

Compression load

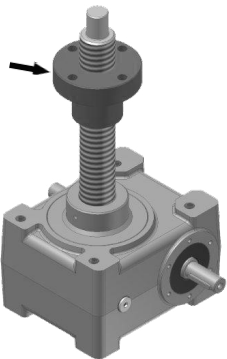

Side load

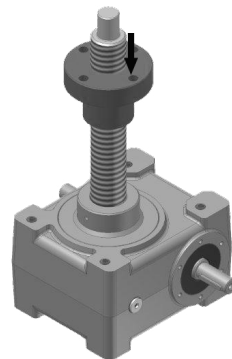

Off-center load



## BACKLASH

### BACKLASH BETWEEN WORMSCREW AND WORMWHEEL

Accurate interface between these two components allows for a low angular backlash. Output movement, i.e. the linear translation of leadscrew, results then 0.1 or lower.

### HT SERIES - RADIAL BACKLASH

Connection between leadscrew profile and inner wormwheel features a certain radial backlash, necessary for a correct workout of screwjack. See drawing A Integration of a 2' guide bushing (optional), allows for lowering such backlash, because it provides more radial stiffness. Traction loads are usually lowering this radial backlash, while compression loads do the opposite.

### HR SERIES - RADIAL BACKLASH

In this series, leadscrew and wormwheel are tightly connected. Concentricity is granted thanx to accurate tooling and coupling. A correct workout for HR series comes from a mounting performing alignment between leadscrew and nutscrew. This is possible via external guides or accurate connections of nutscrew to frame.

### AXIAL BACKLASH

Such backlash, named "B" (between wormwheel/leadscrew for HT and between nutscrew/leadscrew for HR), happens because of necessary tolerance in the connection of these components to drive one on each other. When load is in one direction only (i.e. only traction or only compression), this backlash does not usually affects the application. In case load can change its direction or closer backlash is needed, there is possibility to lower it.

Excessive lowering of backlash, anyway, can overheat system (or even grip it!) due to too strict connection.

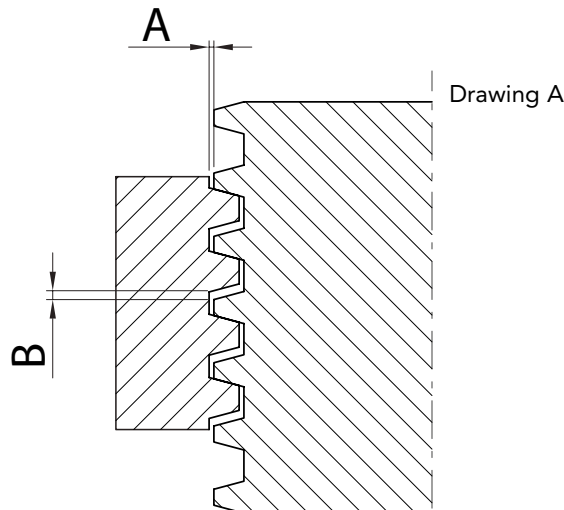

## INPUT DRIVING

### MANUAL DRIVE

Screwjacks can be manually driven via a handwheel, the easiest form of input movement. Dimensions of handwheels in the section *Input Options* (see page 49). Considering a force of 50N on a 250 mm-radius handwheel, max loads (in N) are available according to reduction ratio. Higher loads can be scored by raising handwheel radius or integrating a further reduction stage.

Manual drive max loads [daN]						
Size	05	10	25	50	100	200
Ratio						
1:4	500	1000				
1:5			2000	2000	1800	2000
1:10	500	1000	2500	5000	3700	3700
1:16	500	1000				
1:30	500	1000	2500	5000	9400	9400

### MOTOR INTEGRATION

Size HT200-HR200 features only "bell + coupling". So, except for Size HT200/HR200, motor gets directly connected to gearbox via a motorflange/hollowshaft assembly (IEC standard frames). Each Size of jack features different IEC ratings as for motoflanges. In particular, Size s HT50/HR50 and HT100/HR100, as an option, can also offer the *motor connection with bell-flange and coupling*. For any Size of screwjack, there is wide availability/possibility for special executions of motorflanges for brushless, servomotors, etc.

### ROTATION DIRECTION

Rotation (input) directions and their consequent linear output movements are shown in drawings below.

MecVel standard production provides right handed wormscrews and leadscrews. On request, also left-handed leadscrews

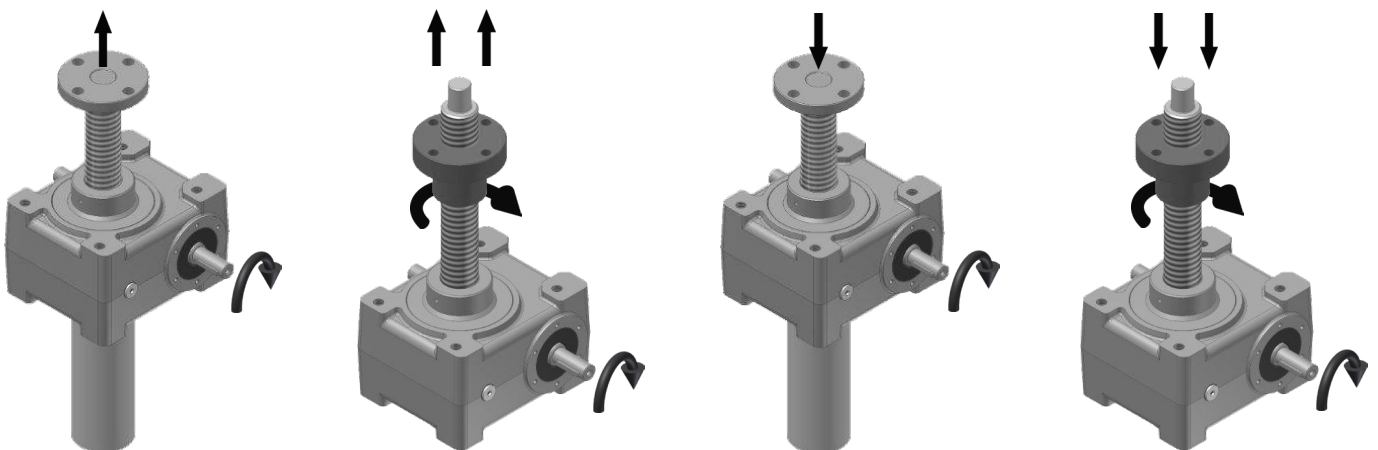

Right handed wormscrew and lead screw.

Right handed wormscrew and left-handed lead screw.



## **EMERGENCY DRIVING**

In case of power failure, screwjacks can be moved manually via some handwheel: to do this, one inputshaft shall be available on the screwjack (or one of the screwjacks if there are more than one connected together) for connection of this handwheel.

If a brakemotor is used, the brake shall be un-clamped firstly, so to allow for movement.

Also, a safety switch should be installed in the control panel, so that no power is supplied to motor while operator is using handwheel.

## **LUBRICATION**

### **GEARSTAGE INTERNAL LUBRICATION**

Gearstage, as standard, is lubricated with synthetic long-life grease. As an option, oil lubrication is also available.

Contact MecVel offices in case some special lubricants (for special purposes, such as food-friendly grease) are needed.

## INSTALLATION

It is extremely important that screwjack gets only axial loads, and no radial ones: so, this shall be considered at earlier design stage. When installing, user shall make sure of perfect perpendicularity between leadscrew and surface where screwjack exerts its force. Also, load to be moved shall be perfectly axial to leadscrew. All this will avoid incorrect working and lubricant leakage.

In case of pulling load, screwjack shall be mounted so that tightening bolts to gearbox are not the ones handling the load. Mechanical stroke-ends damage screwjack and its components. Off-center loads generate radial loads hence lubricant loss and not smooth running.

When starting up screwjack, following checks shall be performed:

- Make sure limit switches (be that integrated on screwjack or external ones) are correctly adjusted and connected so to avoid mechanical stroke-ends.
- When adjusting limit switches (be that integrated on screwjack or external ones) consider eventual inertia of mass to be moved. For example, a pushing/compression vertical load will show more inertia when going down/descending.
- Drive jack by short steps of motor to ascertain right travelling sense of screw (series HT) or nut (series HR) and to test position of limit switches.
- Make sure about general correct alignments: leadscrew/loads, and jacking towards connecting shaft, shaft holders, coupling and motor - neatness and correct lubrication for leadscrew.

All the electrical wirings done during startup phase shall be done without electric power along mains line, so to avoid any possibility of harming operators and/or parts of the system.

**IN CASE SCREWJACK IS DRIVEN VIA A 1-PH MOTOR, MAKE SURE CAPACITORS ARE FULLY DISCHARGED BEFORE MAKING ANY KIND OF OPERATION (RISK OF ELECTRICAL SHOCK).**

We recommend running the first runs with minimum possible load so to check correct workout of system first (screwjack and structure). Testing runs done with lack of attention can damage screwjack or its components, continuous drivings with not enough stopping time can cause jack's overheating hence severe damage, therefore please consider what is explained in this catalogue as extremely important.

**EVEN JUST ONE "SHOCK" (MECHANICAL OR THERMIC) IS ENOUGH TO CAUSE DAMAGES OR EVEN MAJOR BREAKDOWN OF SCREWJACK.**

Use technical information in this catalog so to perform correct choice of screwjack Size and accessories. MecVel rejects any kind of responsibility for any damages coming from wrong / incorrect use of information in this document. MecVel, before shipping screwjacks to customer, checks carefully parts, construction and basic workout of each screwjack being assembled (without load).



## MAINTENANCE

Screwjacks shall be periodically checked: time-schedule is according use and environment where screwjacks are working.

Gearstage for all screwjacks is filled with long-life grease that does not require refills.

Make sure there are no grease leakages from gearbox: if so, search and eliminate its cause, and re-fill lubricant which escaped.

Regarding leadscrew, recurrent control of its cleanliness and correct lubricant layer is necessary.

Safety components of installation shall be Size d according to the laws in force.

### NUT WEAR CHECK-UP

ACME nut shall be recurrently checked.

Following is the list of operations to be done:

- Disconnect operational load from screwjack.
- Apply a load to screwjack, from nominal load down to 0.1 times nominal load, lowering this parameter as screwjack Size increases. This load shall be applied in compression and tension.
- via a gauge-meter, make sure that:

$$\text{Backlash (mm)} \leq 0.25 * \frac{\text{pitch (mm)}}{\text{starts of leadscrews}}$$

When backlash is higher, screwjack needs at least to be serviced, or even replaced.

In case of ballscrew transmission ("VRS" units), first sign of wear is increase of noise-level.

This is why we recommend, even without checking up backlash, to keep screwjack workout monitored, so to make sure it's silent and regular

## SELECTION

### PARAMETERS FOR SCREWJACK SELECTION

The main parameters for a correct selection of a screwjack are:

- load cycle (trend of the load along the stroke),
- travelling speed (trend of the speed along the stroke),
- duty cycle
- environmental conditions
- working stroke of the jack
- supply voltage
- bucking load
- type of constrains
- radial load if any

### LOAD AND TRAVELLING SPEED

Besides their own intrinsic characteristics, load and speed must be evaluated considering the influences generated by the trend of both of them during the working cycle, especially if heavy inertia's phenomena and/or vibrations are present. For example, in case an heavy load travels with a speed trend that provides sudden accelerations and decelerations, the inertial load will have to be added to the static load value and this will of course influence the selection of the jack. In this case please contact MecVel Technical Dept. for assistance.

### DUTY CYCLE AND ENVIRONMENTAL CONDITIONS

Duty cycle and environmental conditions are parameters that influence each other.

Duty cycle is defined as ratio between cycle working time and stop time in percentage, calculated on a time basis of max 5 minutes. Environmental conditions are characterized by the temperature and all the other elements that define their aggressiveness (humidity, saltiness, dust, etc.). Standard duty cycle, to which screwjacks performances are referred, is S3 30% at an ambient temperature of +30 °C. Screwjacks working temperature range is -10 °C/+60 °C.

The duty cycle can be increased by using high efficiency screwjack internal gearings or selecting a bigger Size jack (derating it). Also the working range of temperature can be widened by using specific lubricants and different materials for some of the components (same as for aggressive environments), by decreasing the duty cycle and/or derating the jack.

Considering what mentioned above it is necessary to calculate the "equivalent load".



## BALL SCREWJACKS

Ball screwjacks differ from ACME ones for the following elements:

### 1. SELFLOCKING / BACKDRIVING

Ball screws are absolutely non-selflocking, therefore a brake shall always be integrated, so to avoid backdriving of system.

### 2. ROTATIONAL INPUT AND OUTPUT

“VRS” screwjacks are supplied with right-handed wormscrew and righthanded ballscrew.

Drawing below shows the rotational directions for input and output.

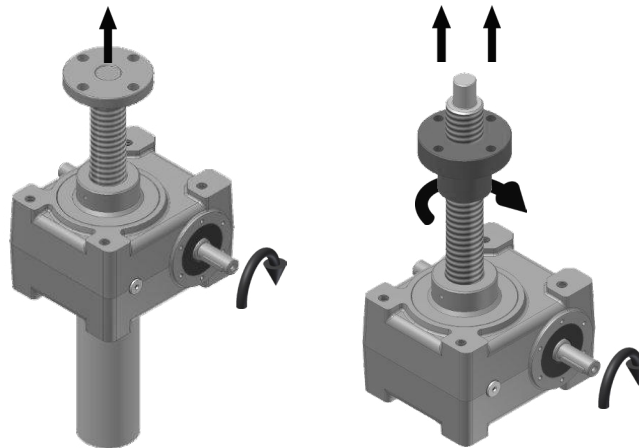

Right handed wormscrew and lead screw.

## EXAMPLES OF SCREWJACK SIZING

Example of lifting system, with just one screwjack involved.

Necessary input-torque for handling a certain load:

$$M_t = \frac{F_e \cdot p}{2000 \cdot 3.14 \cdot \eta_m \cdot i}$$

Necessary input-power for handling a certain load:

$$P = \frac{M_t \cdot n_1}{9550}$$

Linear speed:

$$V = \frac{n_1 \cdot p}{i \cdot 60}$$

That reads as:

$F_e$	equivalent load [N]	$i$	reduction ratio
$P$	power [kW]	$M_t$	motor torque on motorshaft [ Nm]
$p$	leadscrew/ballscrew pitch [mm]	$n_1$	motorspeed [rpm]
$\eta_m$	overall screwjack efficiency	$V$	linear speed [mm/s]



Example of lifting system, with more screwjacks involved see system mounting options, in the following page.

Necessary input-torque for handling a certain load:

$$M_t = \frac{n * F_e * p * \eta_c}{2000 * 3.14 * m * i}$$

Necessary input-power for handling a certain load:

$$P = \frac{M_t * n_1}{9550}$$

P	power necessaria [kW]	$\eta_c$	overall system efficiency = $1 - [(1-N) * 0,05]$
n	numero di martinetti	N	number of screwjacks and bevelgears
$F_e$	equivalent load [N]	i	jack reduction ratio
$\eta_m$	overall screwjack efficiency	p	leadscrew/ballscrew pitch [mm]

When more screwjacks are driven by the same motor, make sure that screwjacks can handle the pass-through torque. Following index shows max admitted momentum for each Size of screwjack.

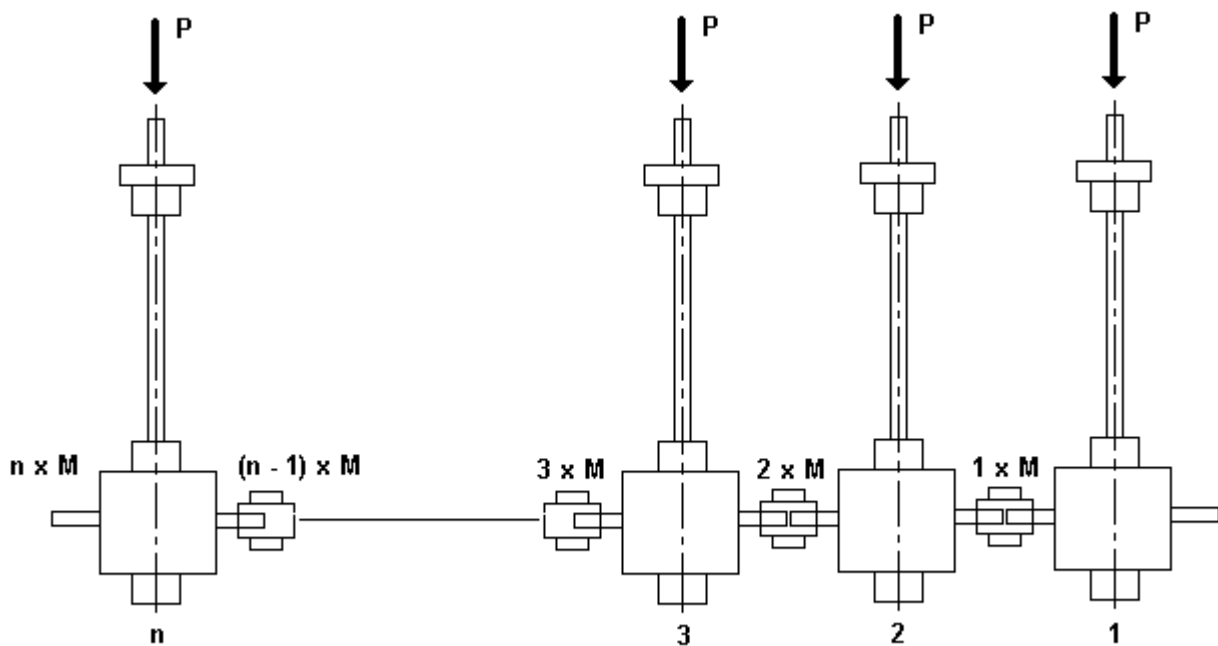

n	number of jacks
M	pass-through torque



# SYSTEM MOUNTING OPTIONS

Screwjack

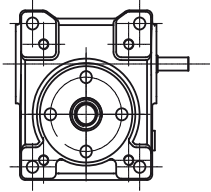

Option A

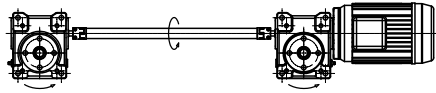

Option B

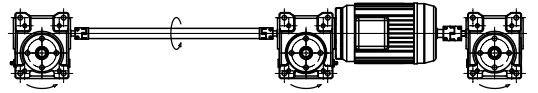

Bevelgear

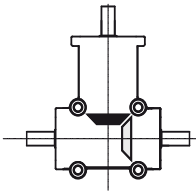

Option C

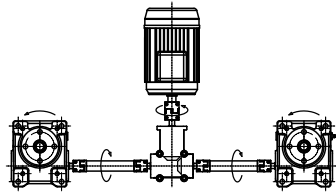

Option D

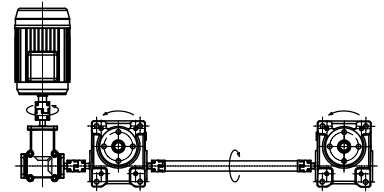

Motor

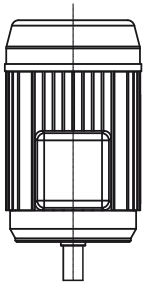

Option E

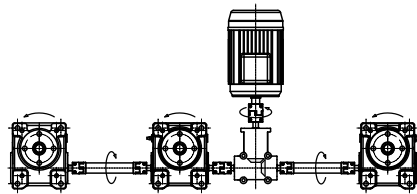

Option F

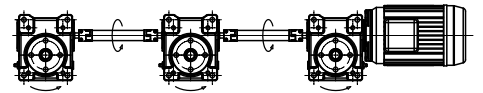

Motor with double shaft

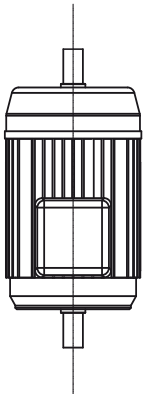

Option G

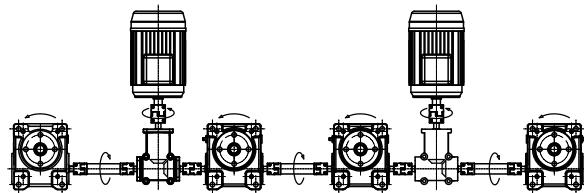

Option H

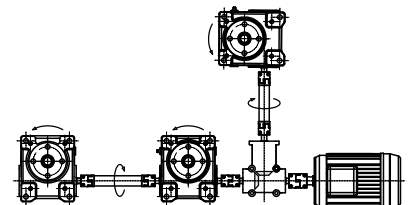

Coupling



Option I

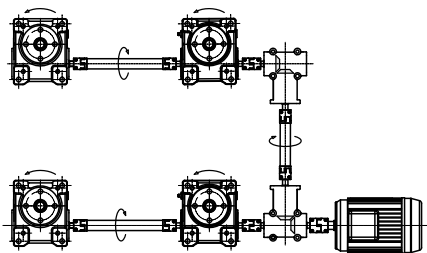

Option L

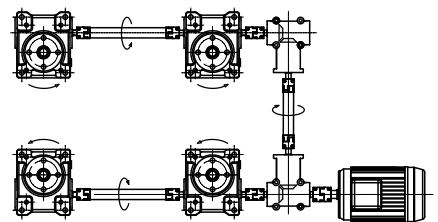

Transmission Shaft



Gearstages for lowering inputspeeds are available upon request.

Screwjack

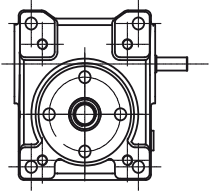

Bevelgear

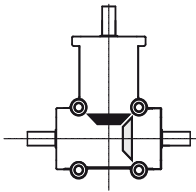

Motor

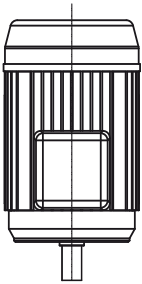

Motor with double shaft

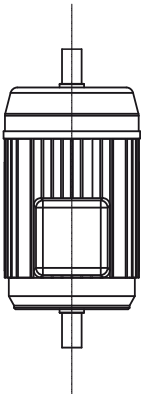

Coupling



Transmission Shaft



Option M

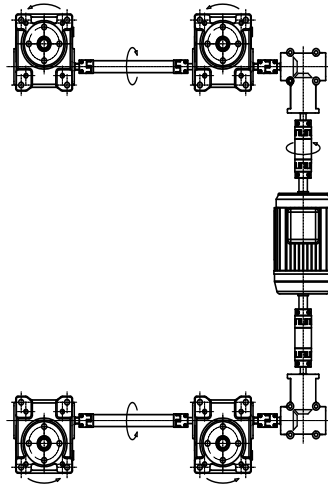

Option N

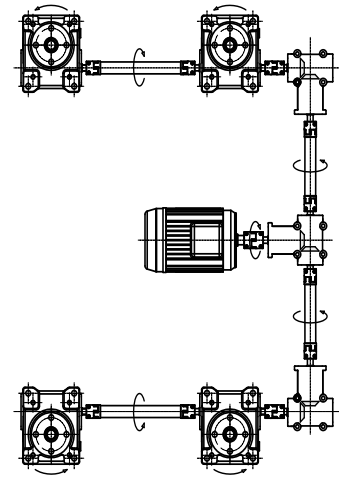

Option O

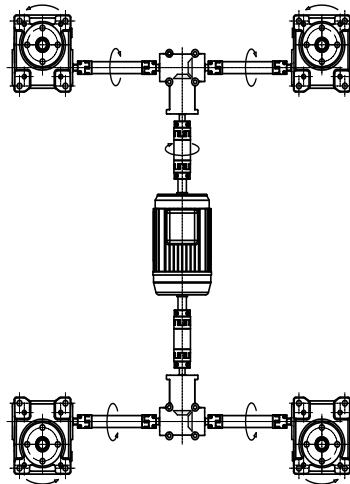

Option P

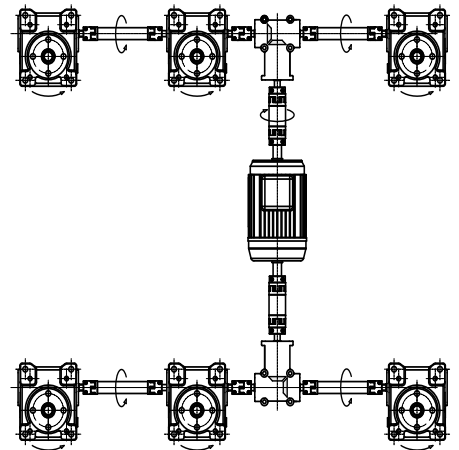

Option Q

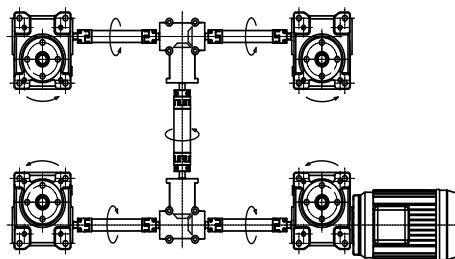

Option R

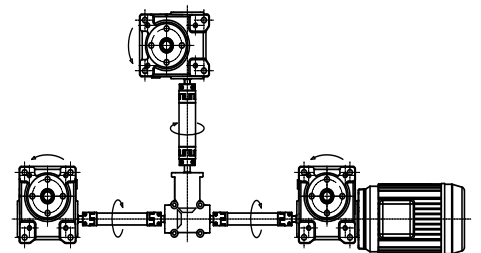

Option S

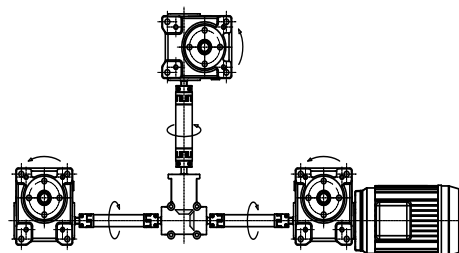



# DIMENSIONS

## HT MODEL

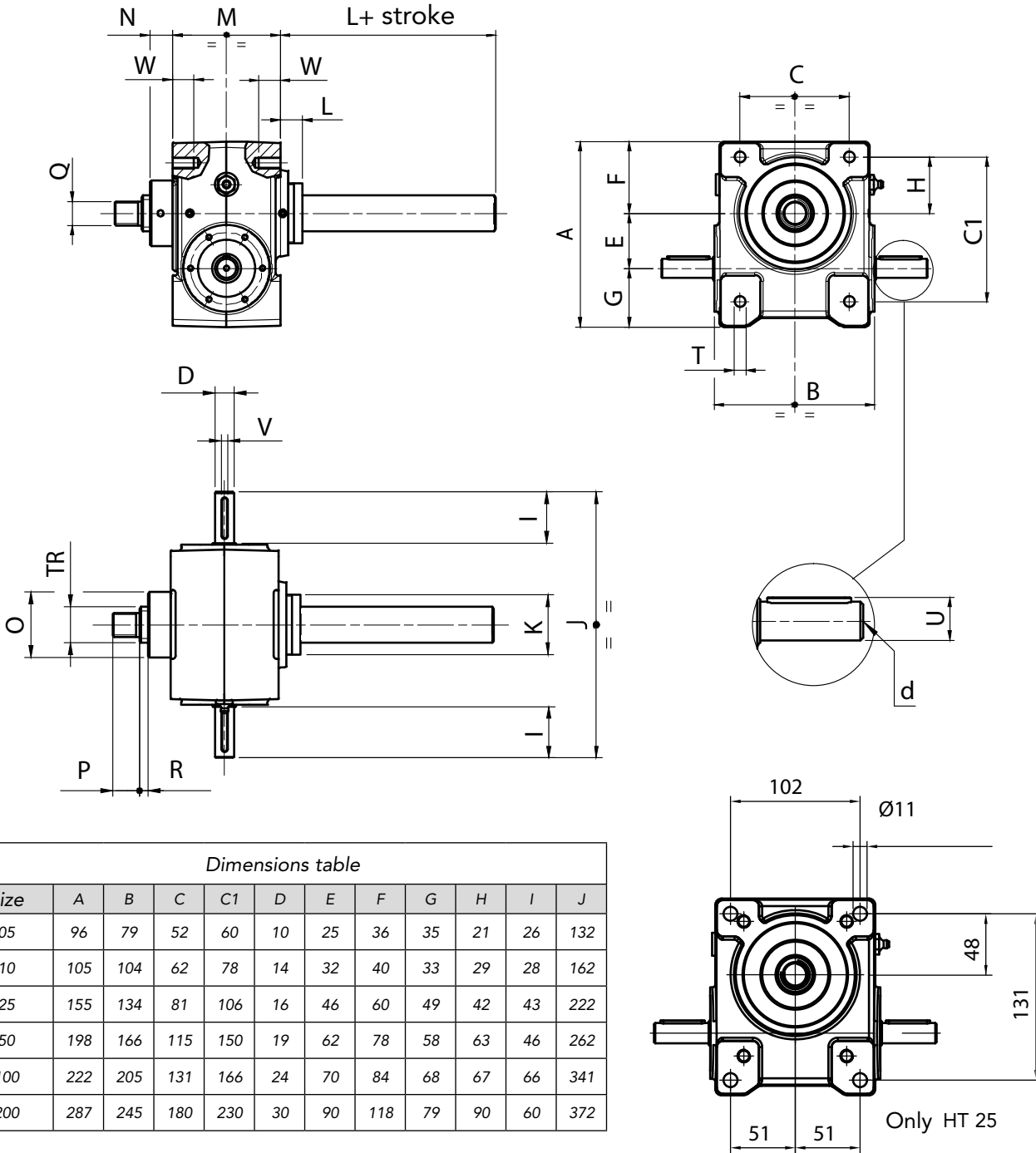

Dimensions table											
Size	A	B	C	C1	D	E	F	G	H	I	J
05	96	79	52	60	10	25	36	35	21	26	132
10	105	104	62	78	14	32	40	33	29	28	162
25	155	134	81	106	16	46	60	49	42	43	222
50	198	166	115	150	19	62	78	58	63	46	262
100	222	205	131	166	24	70	84	68	67	66	341
200	287	245	180	230	30	90	118	79	90	60	372

Dimensions table															
Size	K	L	M	N	O	P	Q	R	T	U	V	W	X	d	TR
05	36	20	70	11	35	17.5	M12	6	M8	11.2	3	15	30	M3	18X4
10	36	20	80	15	40	19	M14	5	M8	16	5	16	35	M5	20X4
25	50	20	90	19	55	22	M20	7	M10	18	5	18	45	M5	30X6
50	70	40	120	29	70	29	M30X2	7	M14	21.5	6	25	57	M6	40X7
100	85	51	160	35	90	45	M36X3	10	M20	27	8	32	72	M10	55X9
200	120	50	192	40	120	58	M56X5.5	10	M30	33	8	45	100	M10	70X10

### HT-VRS MODEL

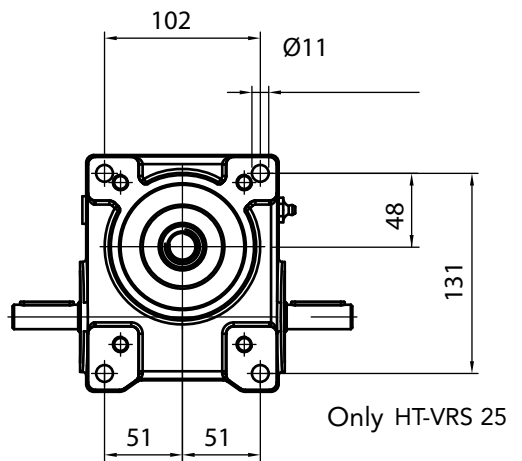
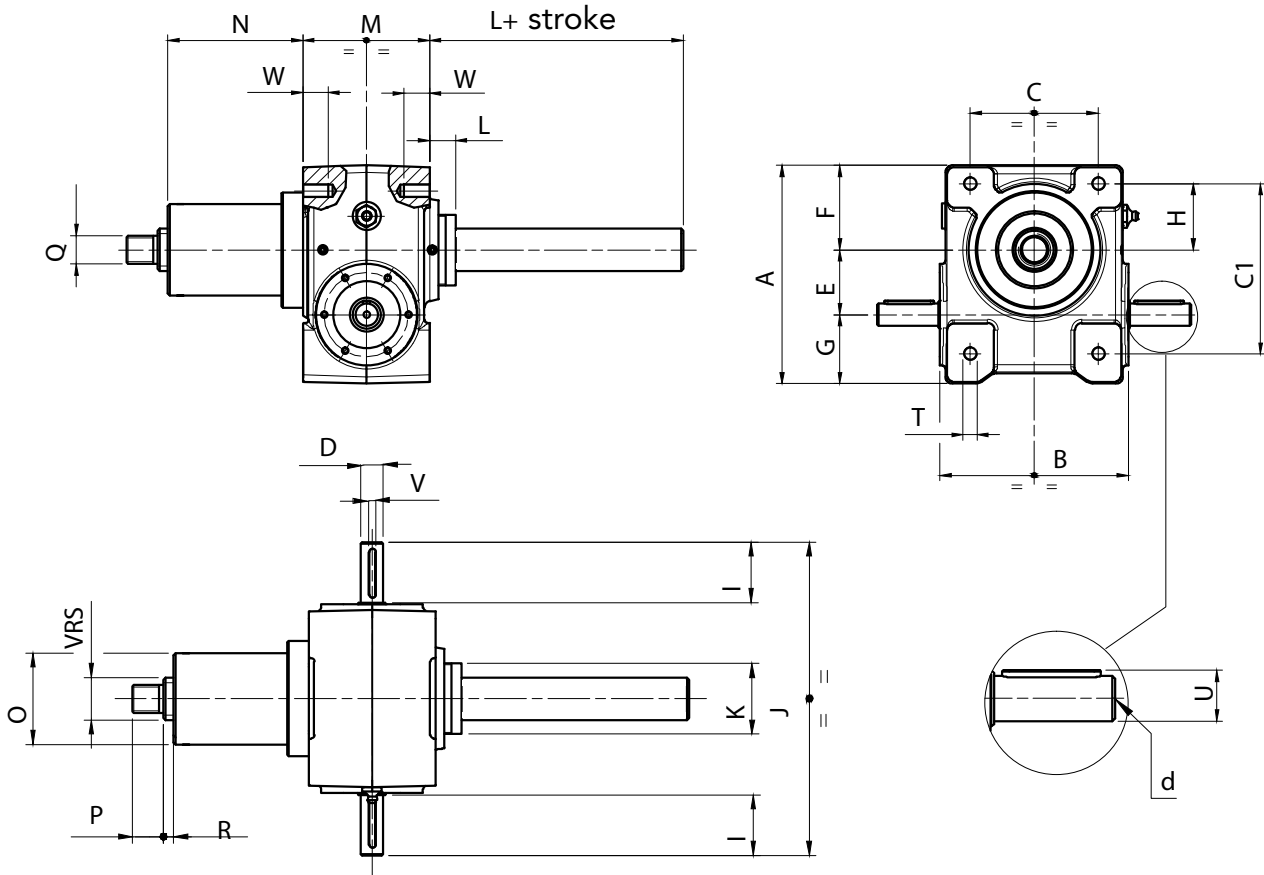

Only HT-VRS 25

Dimensions table											
Size	A	B	C	C1	D	E	F	G	H	I	J
25	155	134	81	106	16	46	60	49	42	43	222
50	198	166	115	150	19	62	78	58	63	46	262
100	222	205	131	166	24	70	84	68	67	66	341
200	287	245	180	230	30	90	118	79	90	60	372

Dimensions table															
Size	K	L	M	N	O	P	Q	R	T	U	V	W	X	d	VRS
25	50	74	90	96	65	22	M20	7	M10	18	5	18	45	M5	32X10
50	70	91	120	105	80	29	M30X2	7	M14	21.5	6	25	57	M6	50X10
100	85	126	160	115	95	45	M36X3	10	M20	27	8	32	72	M10	63X10
200	120	137	192	132	120	58	M56X5.5	10	M30	33	8	45	100	M10	63X20



## HR MODEL

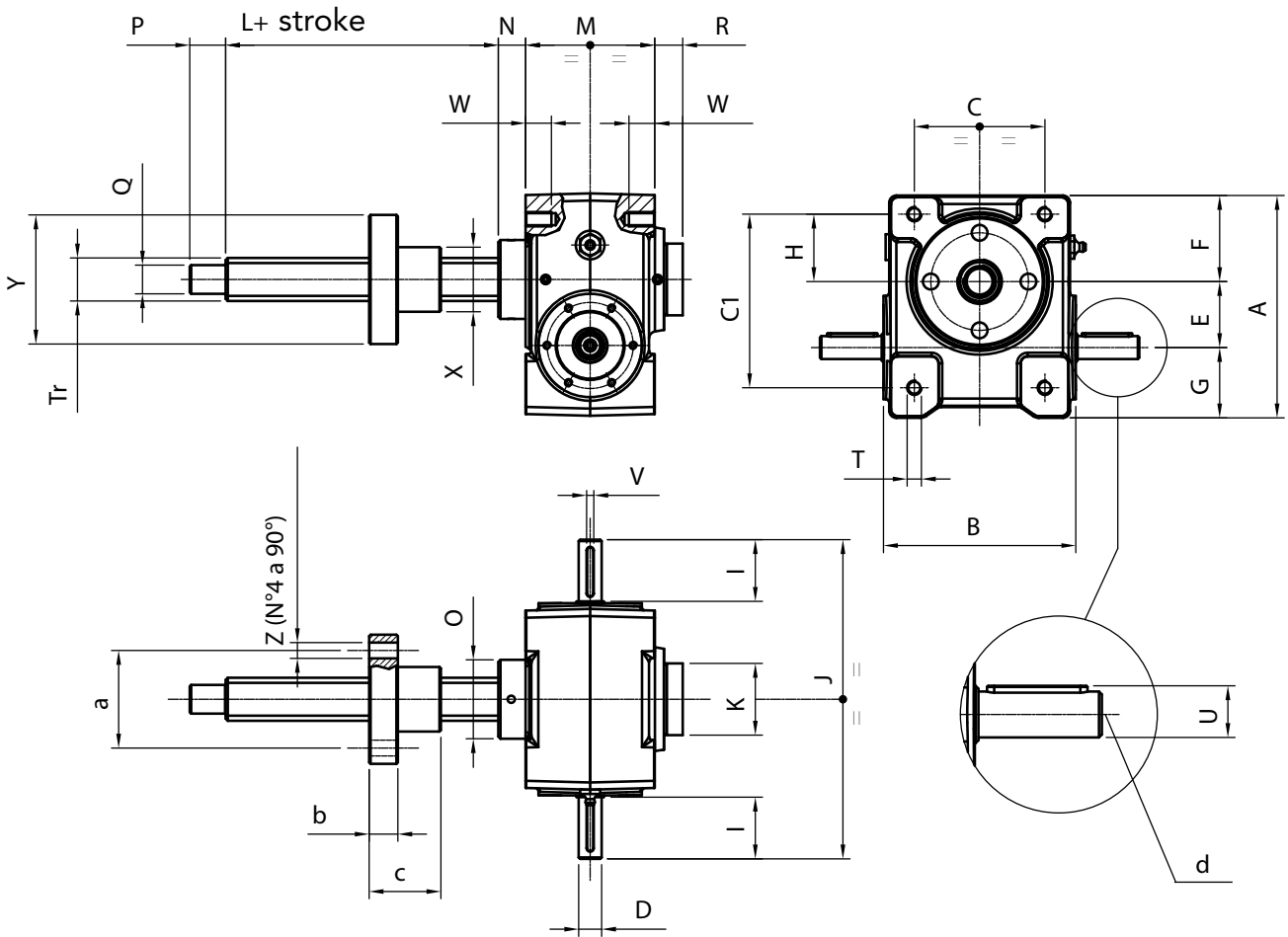

Dimensions table											
Size	A	B	C	C1	D	E	F	G	H	I	J
05	96	79	52	60	10	25	36	35	21	26	132
10	105	104	62	78	14	32	40	33	29	28	162
25	155	134	81	106	16	46	60	49	42	43	222
50	198	166	115	150	19	62	78	58	63	46	262
100	222	205	131	166	24	70	84	68	67	66	341
200	287	245	180	230	30	90	118	79	90	60	372

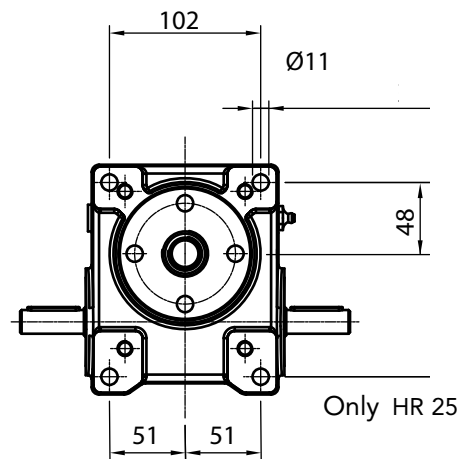

Dimensions table																				
Size	K	L	M	N	O	P	Q	R	T	U	V	W	X	Y	Z	a	b	c	d	TR
05	36	56	70	11	35	16	f12	20	M8	11.2	3	15	30	55	7	43	12	35	M3	18X4
10	36	66	80	15	40	20	f15	17	M8	16	5	16	35	65	9	50	15	40	M5	20X4
25	50	90	90	19	55	25	f20	19	M10	18	5	18	45	90	11	68	20	50	M5	30X6
50	70	120	120	29	70	30	f25	29	M14	21.5	6	25	57	99	11	78	25	70	M6	40X7
100	85	140	160	35	90	40	f40	38	M20	27	8	32	72	129	13	100	30	85	M10	55X9
200	120	165	192	40	120	70	f55	57	M30	33	8	45	100	179	18	140	30	105	M10	70X10

### HR-VRS MODEL

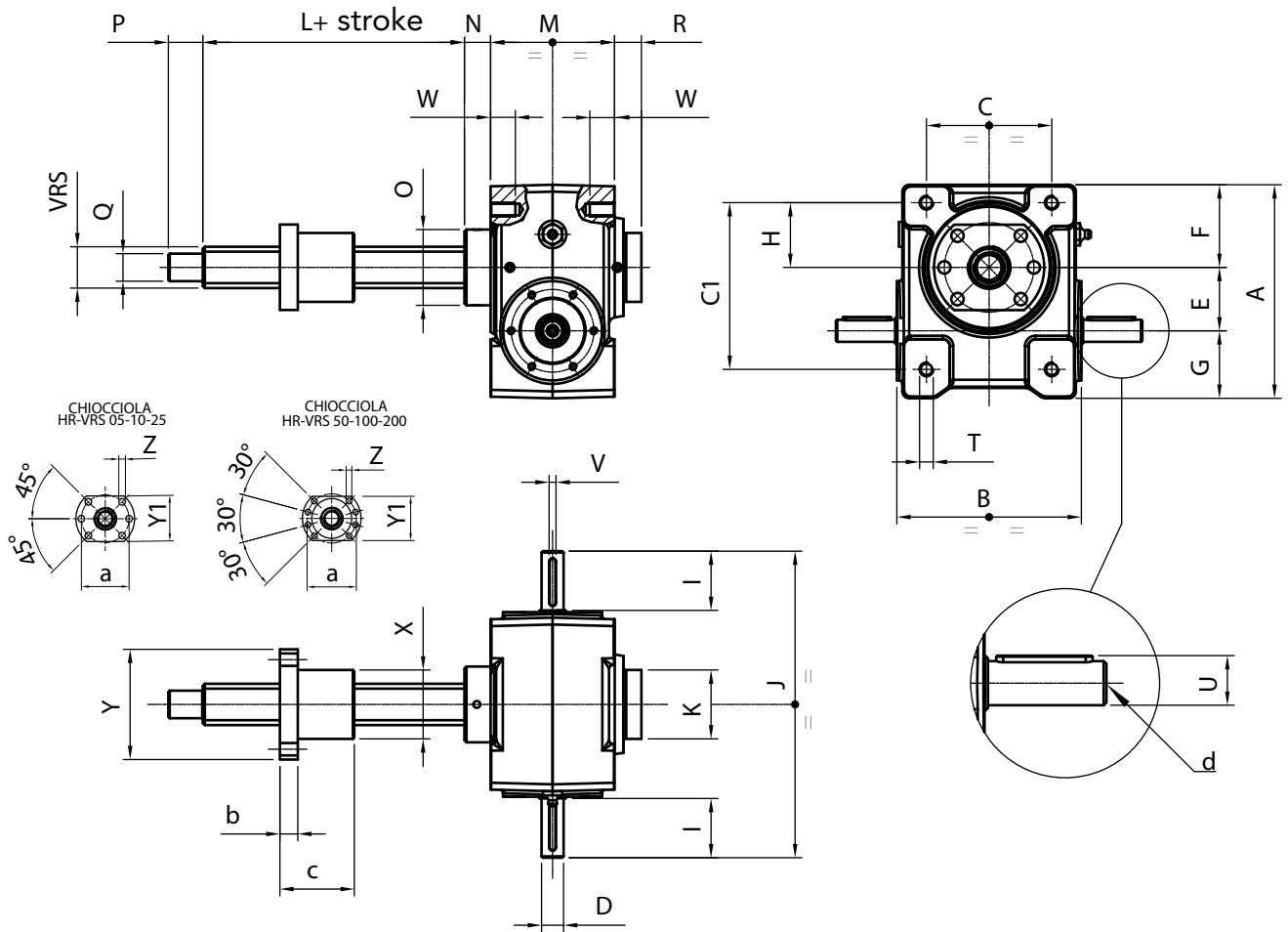

Dimensions table												
Size	A	B	C	C1	D	E	F	G	H	I	J	K
05	96	79	52	60	10	25	36	35	21	26	132	36
10	105	104	62	78	14	32	40	33	29	28	162	36
25	155	134	81	106	16	46	60	49	42	43	222	50
50	198	166	115	150	19	62	78	58	63	46	262	70
100	222	205	131	166	24	70	84	68	67	66	341	85
200	287	245	166	230	30	90	118	79	90	60	372	120

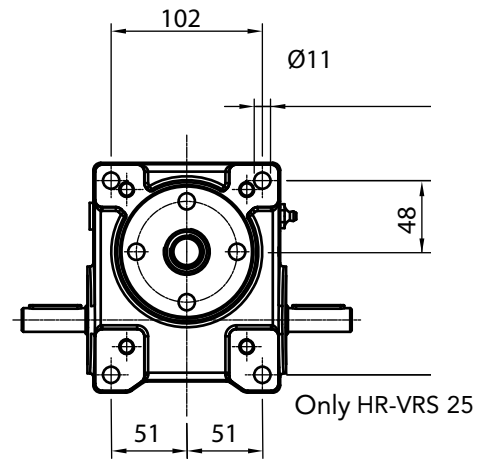

Dimensions table																						
Size	L	M	N	O	P	Q	R	T	U	V	W	X	Y	Y1	Z	a	b	b1	c	d	VRS	
05	76	70	11	35	16	12	20	M8	11.2	3	15	28	48	40	5.5	38	10	5	50	M3	16X5	
10	91	80	15	40	20	15	17	M8	16	5	16	36	58	44	6.5	47	10	5	55	M5	20X5	
25	155	90	19	55	25	20	19	M10	18	5	18	50	80	62	9	65	12	6	118	M5	32X10	
50	190	120	29	70	30	25	29	M14	21.5	6	25	63	93	70	9	78	14	7	142	M6	50X10	
100	200	160	35	90	40	40	38	M20	27	8	32	75	110	85	11	93	16	7	108	M10	63X10	
200	225	192	40	120	70	55	57	M30	33	8	45	90	125	95	11	108	18	7	166	M10	63X20	



## STROKE CONTROL DEVICES: ELECTRIC AND ELECTRONIC OPTIONS

Screwjacks can host different devices for stroke control: mechanical switches or proximity sensors, that generate a signal for switching motorsupply (so-called ON/OFF workout). All wirings and circuitry operations shall be done with unpowered motor, so to avoid any potential harm to operator and damages to screwjack.

### INTEGRATED MECHANICAL SWITCHES (MODEL HR-F ONLY)

Single-contact changeover microswitches, integrated into screwjack gearbox; they get activated via a cam, which gets its own movement from leadscrew revolutions. A compact and well protected system is then available, even tough it's not fully suitable in case of long strokes; for some ratios a rotative potentiometer is also available.

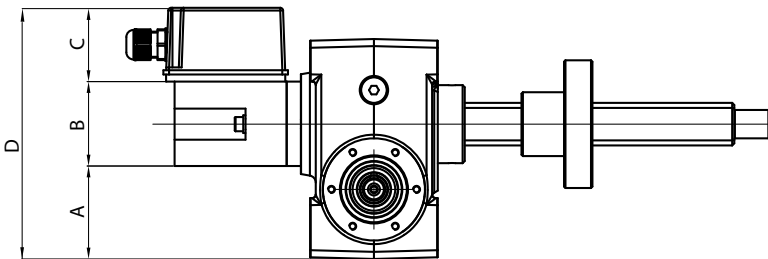

Dimensions table						
Size	A	B	C	D	E	F
05	30	60	52	112	130	74
10	35	60	52	112	130	74
25	65	60	52	112	130	74
50	90	60	52	112	130	74
100	108	60	52	112	150	74
200	Non previsto					

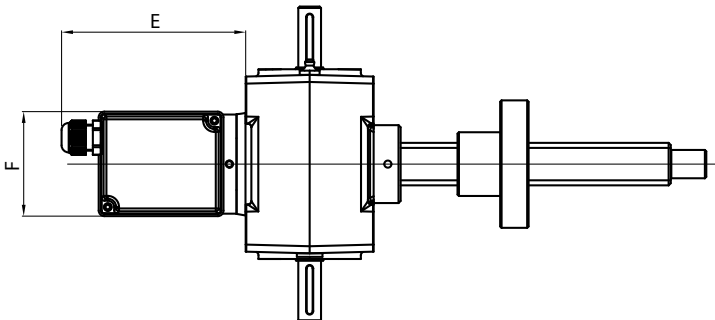

### F LIMIT SWITCHES POSITION

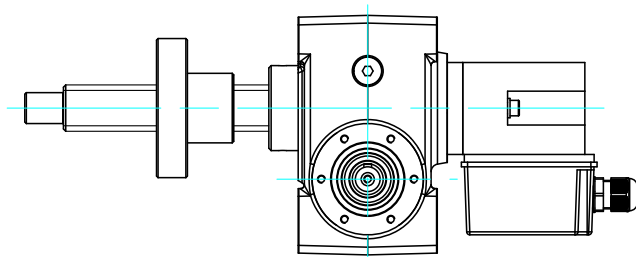
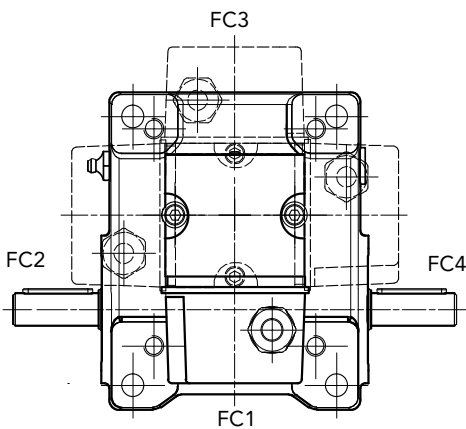



### PROXIMITY SENSORS (MODEL HT-FCI ONLY)

These sensors are mounted on rear-pipe and are not adjustable, therefore position shall be clearly outlined in customer's order.

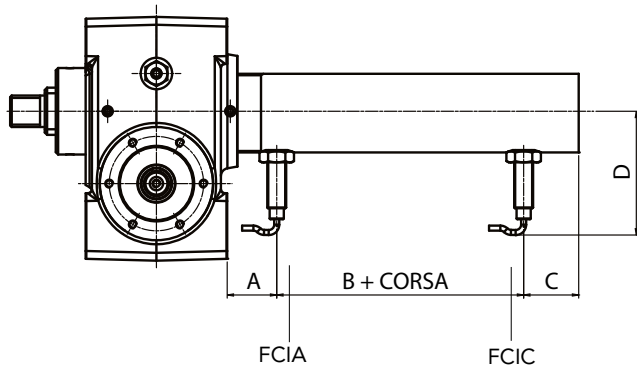

Dimensions table						
Size	05	10	25	50	100	200
A	23	20	32	39	61	60
B	6	6	7	8	8	8
C	26	26	35	44	57	69
D	70	70	77	87	95	112

- FCIC All-closed position inductive sensor
- FCIA All-opened position inductive sensor

Technical data:

- Supply voltage(UB): 5 ÷ 40 Vcc
- Temperature range: - 25° ÷ + 75°C
- Degree of protection: IP67
- Switch status indicator: yellow LED

NO + NC

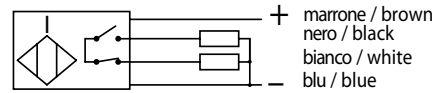

### FCI PROXIMITY SWITCHES POSITION

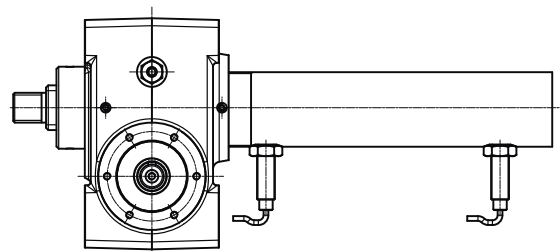
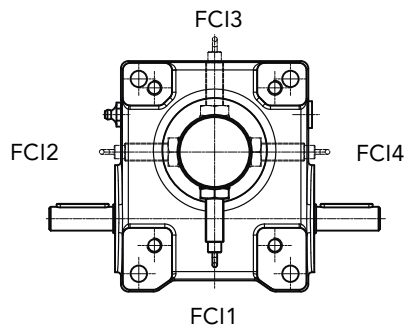

### MAGNETIC LIMIT SWITCHES (MODEL HT-FCM ONLY)

Magnetic sensors are activated by a magnetic field generated by a magnetic ring fixed to the nut. These switches are mounted on outer tube with brackets; outer tube shall therefore be built with non-magnetic materials. This kind of stroke control device cannot be used when antirotation system is needed.

- FCMC All-closed position limit switch
- FCMA All-open position limit switch

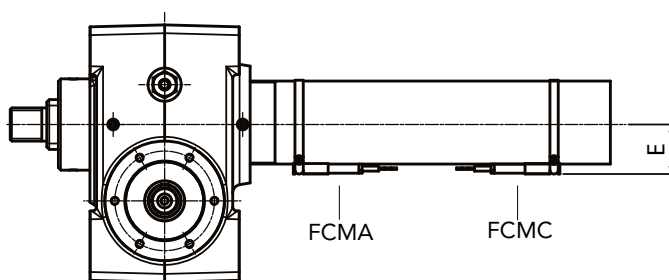

Dimensions table						
Size	05	10	25	50	100	200
E	24	24	31	41	49	66



## FCM LIMIT SWITCH POSITION

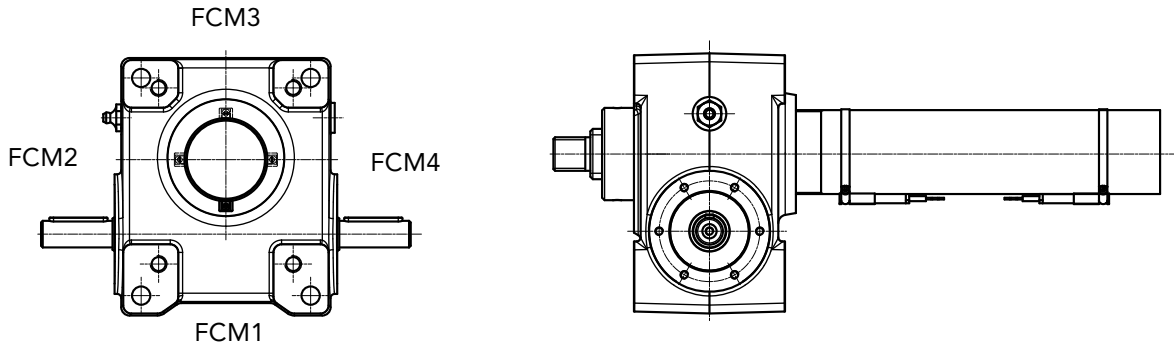

FCM Magnetic Limit Switches			
Performance	Type		
	Reed NC (standard)	Reed NO	PNP
DC voltage	5 / 130 V	5 / 130 V	5 / 130 V
AC voltage	5 / 130 V	5 / 130 V	/
25°C Current	200 mA	200 mA	500 mA
Power	6 W	10 W	6 W
Supply Cable	PVC 2 x 0,14 mm	PVC 2 x 0,14 mm	PVC 3 x 0,14 mm
Cable lenght	2000 mm		
Protection	IP67		

### REED NC CIRCUIT

Circuit with normally closed Reed switch protected by a varistor against overvoltages caused when switching off, with LED indicator.

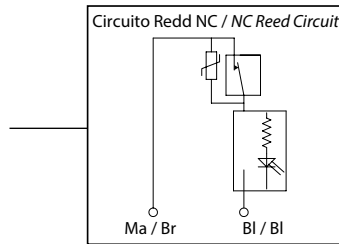

### REED NO CIRCUIT

Circuit with Hall-effect switch and PNP outlet. Protected against overvoltage spikes and reverse of polarity. With LED indicator.

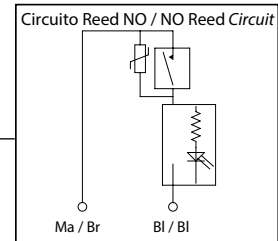

### PNP CIRCUIT

Circuit with normally open Reed switch protected by a varistor against overvoltages caused when switching off, with LED indicator.

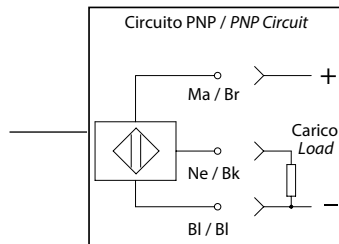

## POTENTIOMETER - POT OPTION (MODEL HR-F ONLY)

This device is hosted inside limitswitches box that hosts also the integrated limit switches. It allows for absolute feedback reference (in terms of resistance value) for position of nutscrew along the stroke. Being geared to integrated switches, it does not fully cope with long strokes. Also, gearing does not always permit complete electrical reading, i.e. a 10KOhm device could read only 6KOhm.

Spinning potentiometer	
Performance	Type
max. angle	340° ± 3°
Resistance	1K / 5K / 10K (standard)
Independent linearity	± 2%
Tolerance	± 20%
Temperature coefficient of resistance	± 600 ppm / °C

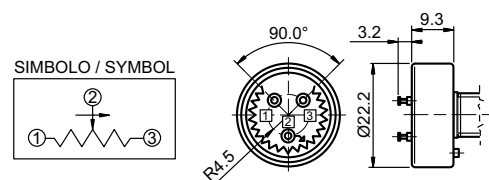

## INTEGRATED LIMIT SWITCHES AND POTENTIOMETER CHARACTERISTICS

Stroke Control devices Assembly (limitsitch)

Stroke Control devices Assembly (limitswitch + potentiometer)

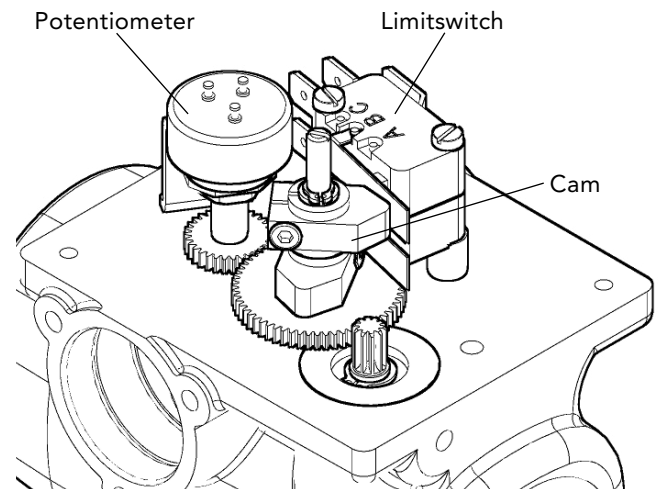
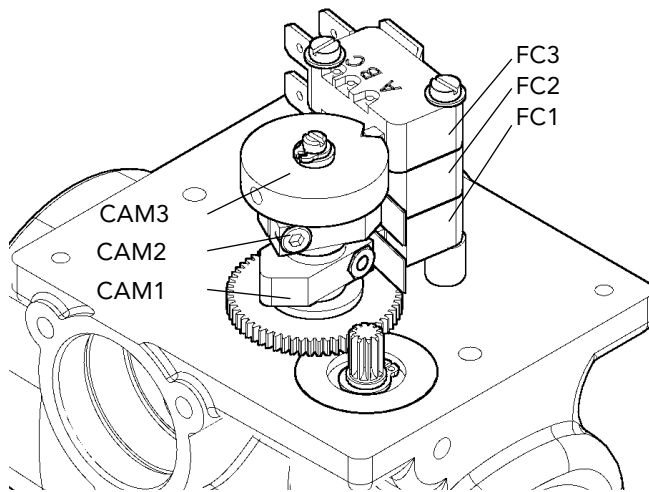

Note for microswitches + potentiometer versions contact our Technical Dept. in case strokes exceed values mentioned on performance tables.

### ENCODER INCREMENTALE - OPTION E

A device that turns a rotational movement into digital pulses. It can be hosted into AC or DC motor, or mounted on shaft opposite to motorside. It does not provide absolute feedback reference, therefore each reset of machine (or mains powersupply failure) will need encoder to be re-setted at "zero".

**WARNING: IN CASE NO LIMIT SWITCHES ARE INCLUDED IN THE SCREWJACK OR FRAMEWORK, WE STRONGLY RECOMMEND MOTORPOWER OVERLOAD DETECTORS TO BE INSTALLED.**

Encoder mounted on AC motors.

Bidirectional incremental encoder, with (standard) or without zero-pulse, protection IP54.

Available ppr: 50 / 100 / 200 / 400 / 500 / 512 / 1000 / 1024 (standard)

Available output circuits: Line Drive 5 Vdc (standard) Push Pull 24 Vdc / Open Collector NPN 10 -30 Vdc / OpenCollector PNP 10 -30 Vdc.



## ORDERING KEY REFERENCES

### MECHANICAL LIMIT SWITCHES

2FC2      2 Micro XGG (only version HR-F)  
3FC2      3 Micro XGG (only version HR-F)

### MAGNETIC LIMIT SWITCHES

Only version HT

2FCM0    2 Sensors circuito Reed NC  
(standard version without prior informations)

2FCM1    2 Sensors circuito Reed NO  
2FCM2    2 Sensors PNP

3FCM0    3 Sensors circuito Reed NC  
(standard version without prior informations)

3FCM1    3 Sensors circuito Reed NO  
3FCM2    3 Sensors PNP

### INDUCTIVE SENSORS

Only version HT

2FCI      2 inductive sensors

### POTENTIOMETERS

POT01A   1 k Ohm (only version HR-F)  
POT05A   5 k Ohm (only version HR-F)  
POT10A   10 k Ohm (only version HR-F)  
(standard versions)

POT01B   1 k Ohm (only version HR-F)  
POT05B   5 k Ohm (only version HR-F)  
POT10B   10 k Ohm (only version HR-F)  
(special versions)

### ENCODER

Only versions HT e HR with motor (on the motor)

E05      Push Pull 1024 ppr  
E06      Line Drive 1024 ppr (standard)  
E07      Open Collector NPN  
E08      Open Collector PNP  
E00      Push pull 2 canali 4 ppr

Only versions HT e HR with motor  
(only on actuator housing)

E09      Push Pull 1024 ppr  
E10      Line Drive 1024 ppr  
E11      Open Collector NPN  
E12      Open Collector PNP

E13      Encoder non contemplato

**SCREWJACKS**  
PRODUCTS

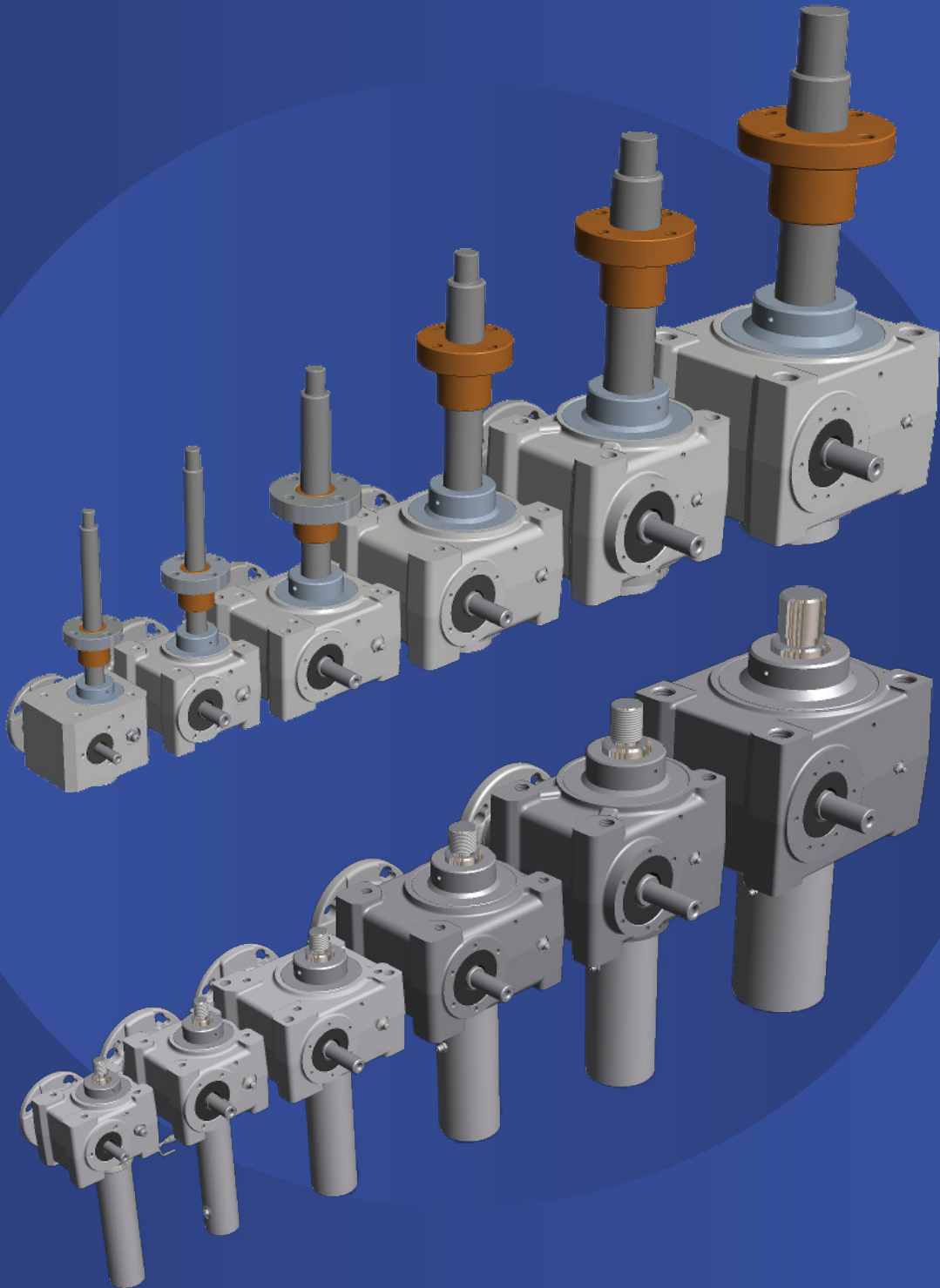



# HT/HR 05

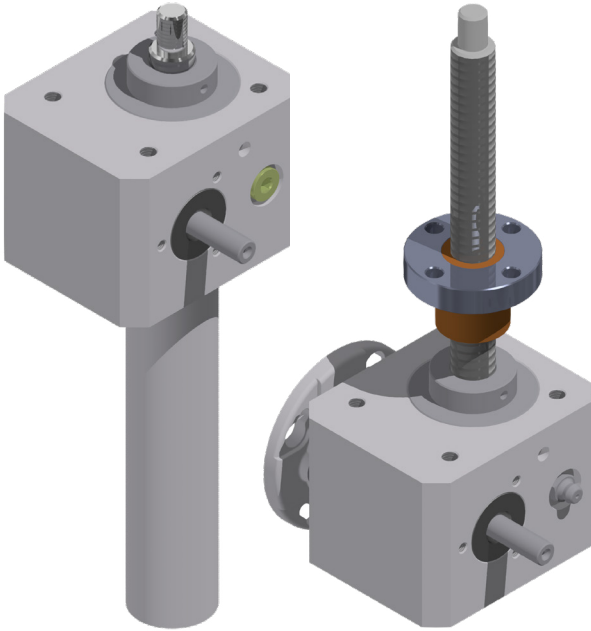

- Tri-phase AC motor (single-phase motor available)
- Worm gearbox
- Acme lead screw or ballscrew (VRS only for HR models)
- Grease or Oil Lubricated
- IP55, ttested according to rule CEI EN 60529  
NB: Only for brake motors Standard IP54, IP65 on request
- Working temperature range -10°C +60°C
- Intermittent duty S3 30% (5 min) a 30°C - for any other request contact MecVel technical dept.
- At-Ex II 3 D T4 version (AC.motor) on request

HR/HT 05						
Fmax (N)	Speed (mm/s)	Version	Motor Size	Power (kW)	Reduction ratio	Pushrod
2000	47	M01	63	0,25 kW 2 poles	1:4	Tr 18x4
5000	19	M02	63	0,37 kW 2 poles	1:10	Tr 18x4
5000	12	M03	63	0,25 kW 2 poles	1:16	Tr 18x4
5000	6	M04	63	0,25 kW 2 poles	1:30	Tr 18x4
5000	22	M05	63	0,37 kW 4 poles	1:4	Tr 18x4
5000	9	M06	63	0,13 kW 4 poles	1:10	Tr 18x4
5000	6	M07	63	0,13 kW 4 poles	1:16	Tr 18x4
5000	3	M08	63	0,13 kW 4 poles	1:30	Tr 18x4
5000	15	M09	71	0,25 kW 6 poles	1:4	Tr 18x4
5000	6	M10	63	0,13 kW 6 poles	1:10	Tr 18x4
5000	4	M11	63	0,13 kW 6 poles	1:16	Tr 18x4
5000	2	M12	63	0,13 kW 6 poles	1:30	Tr 18x4

HR 05 VRS						
Fmax (N)	Speed (mm/s)	Version	Motor Size	Power (kW)	Reduction ratio	Pushrod
5000	58	M01	63	0,37 kW 2 poles	1:4	VRS 16X5
5000	23	M02	63	0,18 kW 2 poles	1:10	VRS 16X5
5000	14	M03	63	0,18 kW 2 poles	1:16	VRS 16X5
5000	8	M04	63	0,18 kW 2 poles	1:30	VRS 16X5
5000	28	M05	63	0,18 kW 4 poles	1:4	VRS 16X5
5000	11	M06	63	0,13 kW 4 poles	1:10	VRS 16X5
5000	7	M07	63	0,13 kW 4 poles	1:16	VRS 16X5
5000	4	M08	63	0,13 kW 4 poles	1:30	VRS 16X5
5000	18	M09	63	0,13 kW 6 poles	1:4	VRS 16X5
5000	7	M10	63	0,09 kW 6 poles	1:10	VRS 16X5
5000	5	M11	63	0,09 kW 6 poles	1:16	VRS 16X5
5000	2	M12	63	0,09 kW 6 poles	1:30	VRS 16X5

→ the brakemotor is strongly recomended .

BEFORE OPERATING ACTUATOR MAKE SURE YOU READ AND UNDERSTOOD BASIC OPERATIONAL INSTRUCTIONS SHOWN ON USERMANUALS, AVAILABLE FROM WEBSITE. In case of specific applications contact MecVel's tech department.

MecVel reserves the right to change products information and/or features without notice; all data contained in this catalogue are purely indicative and not binding for the company.

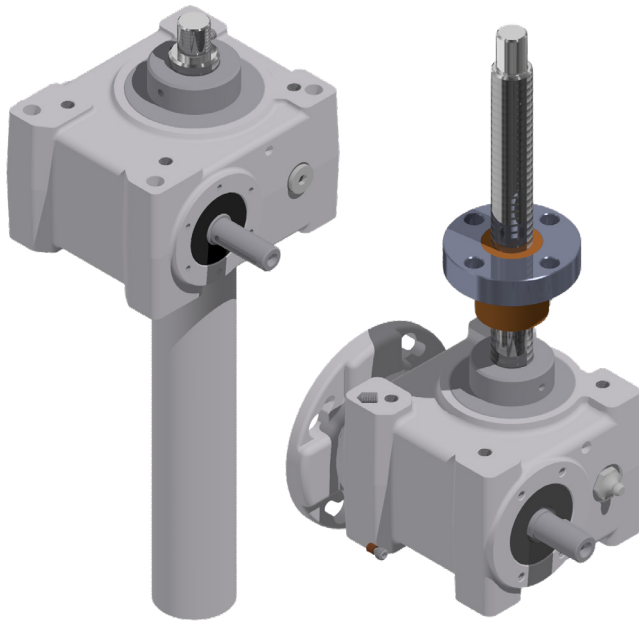

- Tri-phase AC motor (single-phase motor available)
- Worm gearbox
- Acme lead screw or ballscrew (VRS only for HR models)
- Grease or Oil Lubricated
- IP55, ttested according to rule CEI EN 60529  
NB: Only for brake motors Standard IP54, IP65 on request
- Working temperature range -10°C +60°C
- Intermittent duty S3 30% (5 min) a 30°C - for any other request contact MecVel technical dept.
- At-Ex II 3 D T4 version (AC.motor) on request

HR/HT 10						
Fmax (N)	Speed (mm/s)	Version	Motor Size	Power (kW)	Reduction ratio	Pushrod
3000	48	M01	71	0,55 kW 2 poles	1:4	Tr 20x4
7000	19	M02	71	0,55 kW 2 poles	1:10	Tr 20x4
10000	12	M03	71	0,55 kW 2 poles	1:16	Tr 20x4
10000	6	M04	71	0,37 kW 2 poles	1:30	Tr 20x4
5000	23	M05	71	0,37 kW 4 poles	1:4	Tr 20x4
10000	9	M06	71	0,37 kW 4 poles	1:10	Tr 20x4
10000	6	M07	71	0,25 kW 4 poles	1:16	Tr 20x4
10000	3	M08	71	0,25 kW 4 poles	1:30	Tr 20x4
7000	15	M09	71	0,37 kW 6 poles	1:4	Tr 20x4
10000	6	M10	71	0,25 kW 6 poles	1:10	Tr 20x4
10000	4	M11	71	0,18 kW 6 poles	1:16	Tr 20x4
10000	2	M12	71	0,18 kW 6 poles	1:30	Tr 20x4

HR 10 VRS						
Fmax (N)	Speed (mm/s)	Version	Motor Size	Power (kW)	Reduction ratio	Pushrod
10000	59	M01	71	0,75 kW 2 poles	1:4	VRS 20x5
10000	23	M02	63	0,37 kW 2 poles	1:10	VRS 20x5
10000	15	M03	63	0,25 kW 2 poles	1:16	VRS 20x5
10000	8	M04	63	0,25 kW 2 poles	1:30	VRS 20x5
10000	28	M05	63	0,37 kW 4 poles	1:4	VRS 20x5
10000	11	M06	63	0,18 kW 4 poles	1:10	VRS 20x5
10000	7	M07	63	0,13 kW 4 poles	1:16	VRS 20x5
10000	4	M08	63	0,13 kW 4 poles	1:30	VRS 20x5
10000	18	M09	71	0,25 kW 6 poles	1:4	VRS 20x5
10000	7	M10	63	0,13 kW 6 poles	1:10	VRS 20x5
10000	5	M11	63	0,09 kW 6 poles	1:16	VRS 20x5
10000	2	M12	63	0,09 kW 6 poles	1:30	VRS 20x5

→ the brakemotor is strongly recommended .

BEFORE OPERATING ACTUATOR MAKE SURE YOU READ AND UNDERSTOOD BASIC OPERATIONAL INSTRUCTIONS SHOWN ON USERMANUALS, AVAILABLE FROM WEBSITE. In case of specific applications contact MecVel's tech department.



MecVel reserves the right to change products information and/or features without notice; all data contained in this catalogue are purely indicative and not binding for the company.



# HT/HR 25

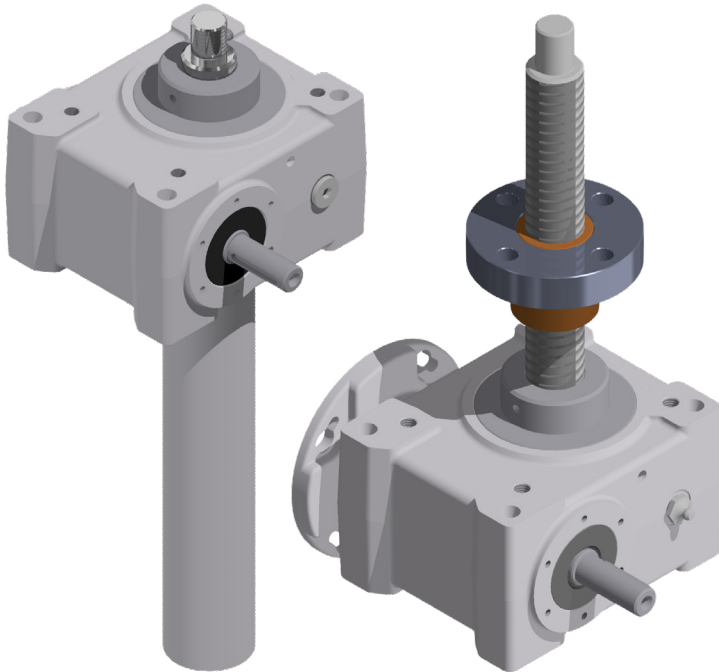

- Tri-phase AC motor (single-phase motor available)
- Worm gearbox
- Acme lead screw or ballscrew (VRS)
- Grease or Oil Lubricated
- IP55, tested according to rule CEI EN 60529  
NB: Only for brake motors Standard IP54, IP65 on request
- Working temperature range -10°C +60°C
- Intermittent duty S3 30% (5 min) a 30°C - for any other request MecVel technical dept.
- At-Ex II 3 D T4 version (AC.motor) on request

HR/HT 25						
Fmax (N)	Speed (mm/s)	Version	Motor Size	Power (kW)	Reduction ratio	Pushrod
4000	56	M01	71	0,75 kW 2 poles	1:5	Tr 30x6
8000	29	M02	80	1,1 kW 2 poles	1:10	Tr 30x6
25000	10	M03	80	1,1 kW 2 poles	1:30	Tr 30x6
8000	28	M04	80	0,88 kW 4 poles	1:5	Tr 30x6
16000	14	M05	80	0,88 kW 4 poles	1:10	Tr 30x6
25000	5	M06	71	0,55 kW 4 poles	1:30	Tr 30x6
12000	18	M07	80	0,75 kW 6 poles	1:5	Tr 30x6
25000	9	M08	80	0,75 kW 6 poles	1:10	Tr 30x6
25000	3	M09	80	0,37 kW 6 poles	1:30	Tr 30x6

HR/HT 25 VRS						
Fmax (N)	Speed (mm/s)	Version	Motor Size	Power (kW)	Reduction ratio	Pushrod
25000	96	M01	90	3 kW 2 poles	1:5	VRS 32x10
25000	47	M02	80	1,8 kW 2 poles	1:10	VRS 32x10
25000	16	M03	71	0,75 kW 2 poles	1:30	VRS 32x10
25000	48	M04	90	1,5 kW 4 poles	1:5	VRS 32x10
25000	24	M05	80	0,75 kW 4 poles	1:10	VRS 32x10
25000	8	M06	71	0,37 kW 4 poles	1:30	VRS 32x10
25000	31	M07	90	1,1 kW 6 poles	1:5	VRS 32x10
25000	16	M08	80	0,55 kW 6 poles	1:10	VRS 32x10
25000	5	M09	71	0,25 kW 6 poles	1:30	VRS 32x10

→ the brakemotor is strongly recommended .

BEFORE OPERATING ACTUATOR MAKE SURE YOU READ AND UNDERSTOOD BASIC OPERATIONAL INSTRUCTIONS SHOWN ON USERMANUALS, AVAILABLE FROM WEBSITE. In case of specific applications contact MecVel's tech department.



MecVel reserves the right to change products information and/or features without notice; all data contained in this catalogue are purely indicative and not binding for the company.



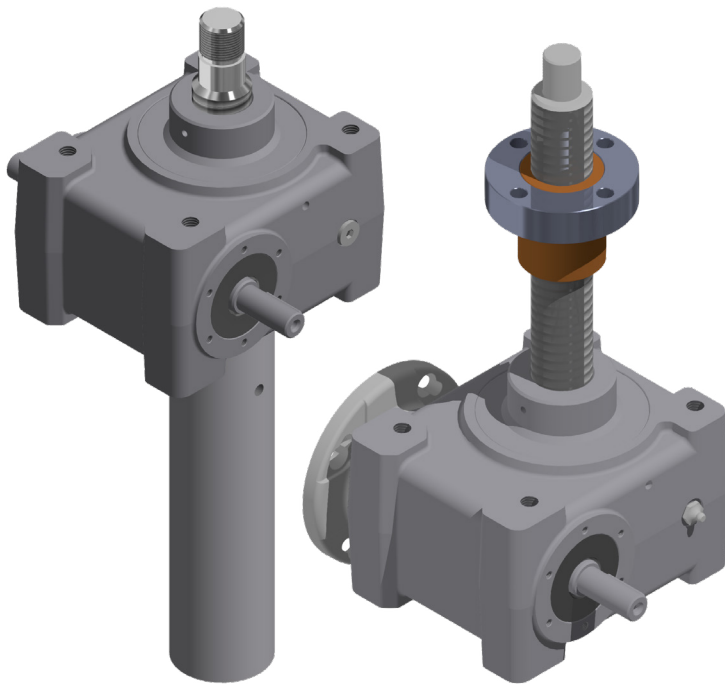

- Tri-phase AC motor (single-phase motor available)
- Worm gearbox
- Acme lead screw or ballscrew (VRS)
- Grease or Oil Lubricated
- IP55, tested according to rule CEI EN 60529  
NB: Only for brake motors Standard IP54, IP65 on request
- Working temperature range -10°C +60°C
- Intermittent duty S3 30% (5 min) a 30°C - for any other request contact MecVel technical dept.
- At-Ex II 3 D T4 version (AC.motor) on request

HR/HT 50						
Fmax (N)	Speed (mm/s)	Version	Motor Size	Power (kW)	Reduction ratio	Pushrod
6000	67	M01	90	1,5 kW 2 poles	1:5	Tr 40x7
11000	34	M02	90	1,5 kW 2 poles	1:10	Tr 40x7
32000	11	M03	80	1,8 kW 2 poles	1:30	Tr 40x7
11000	33	M04	90	1,5 kW 4 poles	1:5	Tr 40x7
22000	17	M05	90	1,5 kW 4 poles	1:10	Tr 40x7
50000	6	M06	90	1,5 kW 4 poles	1:30	Tr 40x7
18000	22	M07	90	1,5 kW 6 poles	1:5	Tr 40x7
35000	11	M08	90	1,5 kW 6 poles	1:10	Tr 40x7
50000	4	M09	90	1,1 kW 6 poles	1:30	Tr 40x7

HR/HT 50 VRS						
Fmax (N)	Speed (mm/s)	Version	Motor Size	Power (kW)	Reduction ratio	Pushrod
25000	96	M01	90	3 kW 2 poles	1:5	VRS 50x10
50000	48	M02	90	3 kW 2 poles	1:10	VRS 50x10
50000	16	M03	80	1,5 kW 2 poles	1:30	VRS 50x10
25000	48	M04	90	1,5 kW 4 poles	1:5	VRS 50x10
50000	24	M05	90	1,5 kW 4 poles	1:10	VRS 50x10
50000	8	M06	80	0,75 kW 4 poles	1:30	VRS 50x10
37000	31	M07	90	1,5 kW 6 poles	1:5	VRS 50x10
50000	15	M08	90	1,1 kW 6 poles	1:10	VRS 50x10
50000	5	M09	80	0,55 kW 6 poles	1:30	VRS 50x10

→ the brakemotor is strongly recommended .

BEFORE OPERATING ACTUATOR MAKE SURE YOU READ AND UNDERSTOOD BASIC OPERATIONAL INSTRUCTIONS SHOWN ON USERMANUALS, AVAILABLE FROM WEBSITE. In case of specific applications contact MecVel's tech department.



MecVel reserves the right to change products information and/or features without notice; all data contained in this catalogue are purely indicative and not binding for the company.



# HT/HR 100

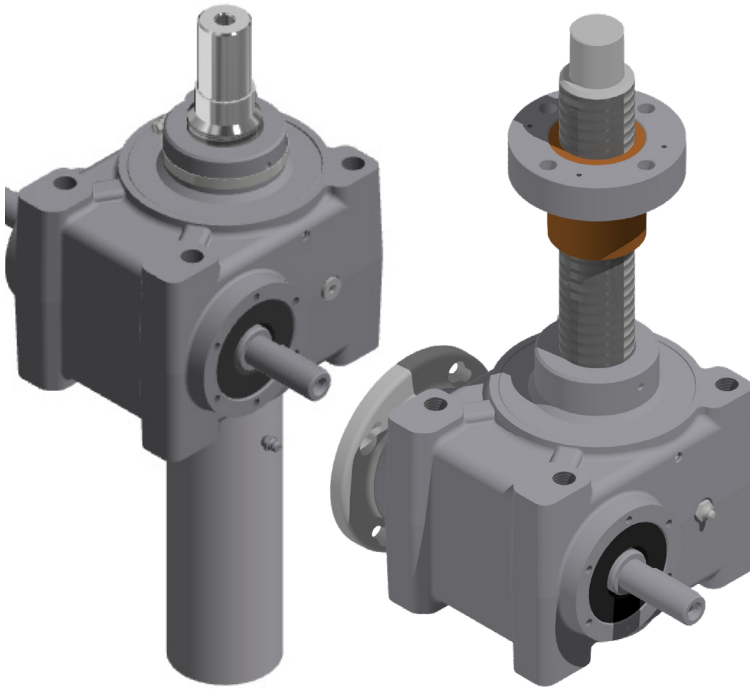

- Tri-phase AC motor (single-phase motor available)
- Worm gearbox
- Acme lead screw or ballscrew (VRS)
- Grease or Oil Lubricated
- IP55, tested according to rule CEI EN 60529  
NB: Only for brake motors Standard IP54, IP65 on request
- Working temperature range -10°C +60°C
- Intermittent duty S3 30% (5 min) a 30°C - for any other request contact MecVel technical dept.
- At-Ex II 3 D T4 version (AC.motor) on request

HR/HT 100						
Fmax (N)	Speed (mm/s)	Version	Motor Size	Power (kW)	Reduction ratio	Pushrod
7000	87	M01	100	3 kW 2 poles	1:5	Tr 55x9
13000	44	M02	100	3 kW 2 poles	1:10	Tr 55x9
40000	15	M03	100	3 kW 2 poles	1:30	Tr 55x9
13000	43	M04	100	2,2 kW 4 poles	1:5	Tr 55x9
26000	22	M05	100	2,2 kW 4 poles	1:10	Tr 55x9
100000	7	M06	100	4 kW 4 poles	1:30	Tr 55x9
22000	29	M07	112	3 kW 6 poles	1:5	Tr 55x9
45000	14	M08	112	3 kW 6 poles	1:10	Tr 55x9
100000	5	M09	112	3 kW 6 poles	1:30	Tr 55x9

HR/HT 100 VRS						
Fmax (N)	Speed (mm/s)	Version	Motor Size	Power (kW)	Reduction ratio	Pushrod
60000	98	M01	112	7,5 kW 2 poles	1:5	VRS 63x10
100000	49	M02	112	7,5 kW 2 poles	1:10	VRS 63x10
100000	16	M03	100	3 kW 2 poles	1:30	VRS 63x10
100000	48	M04	112	5,5 kW 4 poles	1:5	VRS 63x10
100000	24	M05	100	3 kW 4 poles	1:10	VRS 63x10
100000	8	M06	100	2,2 kW 4 poles	1:30	VRS 63x10
75000	32	M07	112	3 kW 6 poles	1:5	VRS 63x10
100000	16	M08	112	2,2 kW 6 poles	1:10	VRS 63x10
100000	5	M09	100	1,5 kW 6 poles	1:30	VRS 63x10

→ The brakemotor is strongly recommended .

BEFORE OPERATING ACTUATOR MAKE SURE YOU READ AND UNDERSTOOD BASIC OPERATIONAL INSTRUCTIONS SHOWN ON USERMANUALS, AVAILABLE FROM WEBSITE. In case of specific applications contact MecVel's tech department.

 MecVel reserves the right to change products information and/or features without notice; all data contained in this catalogue are purely indicative and not binding for the company.

# HT/HR 200

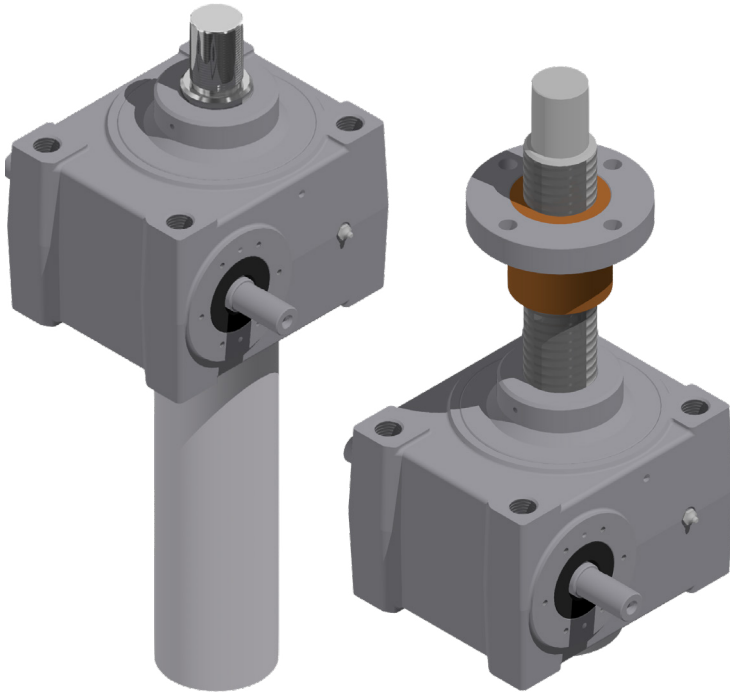

- Tri-phase AC motor (single-phase motor available)
- Worm gearbox
- Acme lead screw or ballscrew (VRS)
- Grease or Oil Lubricated
- IP55, tested according to rule CEI EN 60529  
NB: Only for brake motors Standard IP54, IP65 on request
- Working temperature range -10°C +60°C
- Intermittent duty S3 30% (5 min) a 30°C - for any other request contact MecVel technical dept.
- At-Ex II 3 D T4 version (AC.motor) on request

HR/HT 200						
Fmax (N)	Speed (mm/s)	Version	Motor Size	Power (kW)	Reduction ratio	Pushrod
10000	98	M01	112	4 kW 2 poles	1:5	Tr 70x10
20000	49	M02	112	4 kW 2 poles	1:10	Tr 70x10
60000	16	M03	112	5,5 kW 2 poles	1:30	Tr 70x10
20000	48	M04	112	4 kW 4 poles	1:5	Tr 70x10
40000	24	M05	112	4 kW 4 poles	1:10	Tr 70x10
120000	8	M06	112	5,5 kW 4 poles	1:30	Tr 70x10
30000	32	M07	132	4 kW 6 poles	1:5	Tr 70x10
60000	16	M08	132	5,5 kW 6 poles	1:10	Tr 70x10
200000	5	M09	132	5,5 kW 6 poles	1:30	Tr 70x10

HR/HT 200 VRS						
Fmax (N)	Speed (mm/s)	Version	Motor Size	Power (kW)	Reduction ratio	Pushrod
120000	98	M01	132	15 kW 2 poles	1:10	VRS 63x20
200000	33	M02	132	15 kW 2 poles	1:30	VRS 63x20
120000	49	M03	132	7,5 kW 4 poles	1:10	VRS 63x20
200000	16	M04	132	5,5 kW 4 poles	1:30	VRS 63x20
70000	6.5	M05	132	5,5 kW 6 poles	1:5	VRS 63x20
200000	11	M06	112	3 kW 6 poles	1:30	VRS 63x20

→ The brakemotor is strongly recommended .

BEFORE OPERATING ACTUATOR MAKE SURE YOU READ AND UNDERSTOOD BASIC OPERATIONAL INSTRUCTIONS SHOWN ON USERMANUALS, AVAILABLE FROM WEBSITE. In case of specific applications contact MecVel's tech department.



MecVel reserves the right to change products information and/or features without notice; all data contained in this catalogue are purely indicative and not binding for the company.



## ACCESSORI

In the order, use these keys to indicate the option/accessories needed for your screw jack:

T0	STANDARD FIXING EYELET
T1	STANDARD FIXING EYELET TURNED BY 90
TS0	NOT STANDARD FIXING EYELET
TS1	NOT STANDARD FIXING EYELET TURNED BY 90
TF	STANDARD FIXING FLANGED
TFS	NOT STANDARD FIXING FLANGED
TA3	FIXING CLEVIS
TA4	FIXING BALL JOINT
K	ADDITIONAL GEARBOX HOLE-SETTINGS
LF	FASTENING STRIPS
OA	ROCKING OPERATION SUPPORTS
OP	INTEGRATED ROCKING OPERATION SUPPORTS
SP ... P	SWINGING MOUNTING FEET
B	BELLOWS BOOT
PO	REAR-PIPE FOR SWINGING MOVEMENT
L	ANTIROTATION
GS	STEEL SAFETY NUT
G	BRONZE SAFETY NUT WITH VISUAL WEAR CECK
GU	BRONZE SAFETY NUT, WITH AUTOMATIC AND VISUAL WEAR CHECK
U	DOUBLE SCREW WITH RIGHT AND LEFT THREAD
V	SCREWJACKS WITH INCREASED SIZE OF SCREW
H	HANDWHEEL FOR MANUAL DRIVING
CG	MOTOR CONNECTION, WITH BELL-FLANGE AND COUPLING

- Standard ordering key:

**HT25-FCI/0250/1:10+4/CA-400-50-T-71-4-0.37/S3+IP65+AB/02/1/E05/2FCI/POTO1A/FCI1/IP65/SF**

- Oredring key with options:

**HT25-FCI/0250/1:10+4/CA-400-50-T-71-4-0.37/S3+IP65+AB/02/1/E05/2FCI/POTO1A/FCI1/IP65/SF/B+C+H**

- Ordering key with special client's drawing:

**HT25-FCI/0250/1:10+4/CA-400-50-T-71-4-0.37/S3+IP65+AB/02/1/E05/2FCI/POTO1A/FCI1/IP65/SF/N.DIS.**

## OPTIONS AND ACCESSORIES

### FRONT FIXING

Besides standard front fixings, other customized ones can also be supplied: they must be selected according to the type of installation of the jack in order to avoid as much as possible the load being not perfectly axial (load eccentricities). Please notice that the reaction torque that is applied to the nut under load is transferred to the front fixings hence, in case of clevis or ball joint, an antirotation device needs to be also provided (only on HT models).

#### OPTION T0 - STANDARD FIXING EYELET

&

#### T1 - STANDARD FIXING EYELET TURNED BY 90

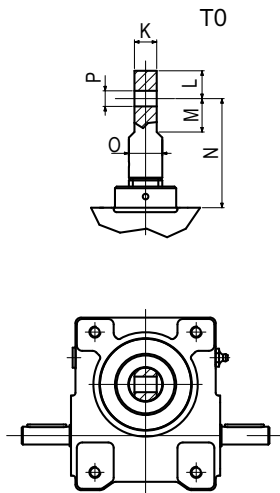

Dimensions table						
Size	K	L	M	N	O	P (FH9)
05	12	15	22	68	Ø18	Ø10
10	14	20	25	89	Ø20	Ø12
25	20	25	30	102	Ø30	Ø14
50	30	25	30	117	Ø40	Ø22
100	42	35	40	154	Ø55	Ø30
200	55	50	50	145	Ø70	Ø40

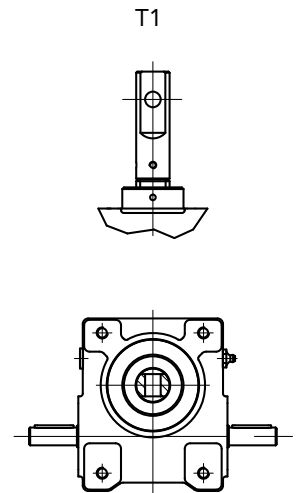

#### OPTION TS0 - NOT STANDARD FIXING EYELET

&

#### TS1 - NOT STANDARD FIXING EYELET TURNED BY 90

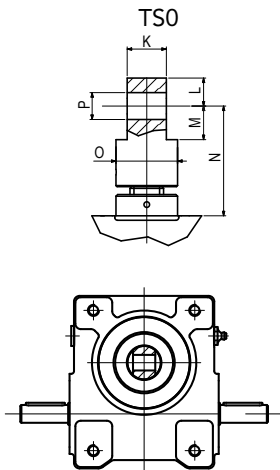

Dimensions table						
Size	K	L	M	N	O	P (FH9)
10	25	20	20	80	Ø38	Ø20
25	30	25	25	115	Ø48	Ø25
50	40	35	35	150	Ø68	Ø35
100	40	50	50	205	Ø98	Ø50
200	75	60	60	235	Ø108	Ø60

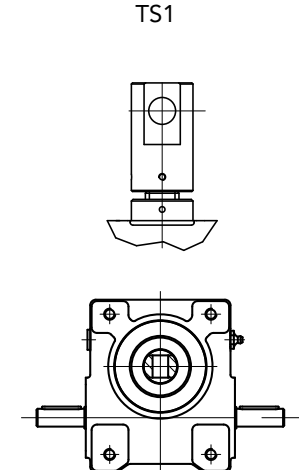

#### OPTION TF - STANDARD FIXING FLANGED

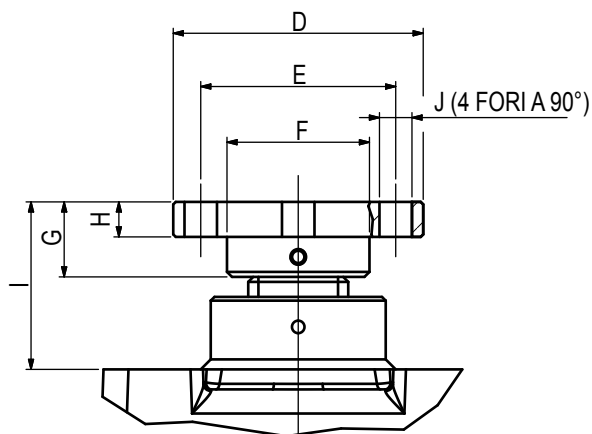

Dimensions table							
Size	D	E	F	G	H	I	J
05	Ø55	Ø43	Ø30	18	10	34.5	Ø7
10	Ø65	Ø50	Ø35	20	12	40	Ø9
25	Ø90	Ø68	Ø45	22	12	48	Ø11
50	Ø100	Ø78	Ø57	30	12	66	Ø13
100	Ø130	Ø100	Ø72	45	20	90	Ø17
200	Ø198	Ø155	Ø105	60	30	110	Ø25



### OPTION TFS - NOT STANDARD FIXING FLANGED

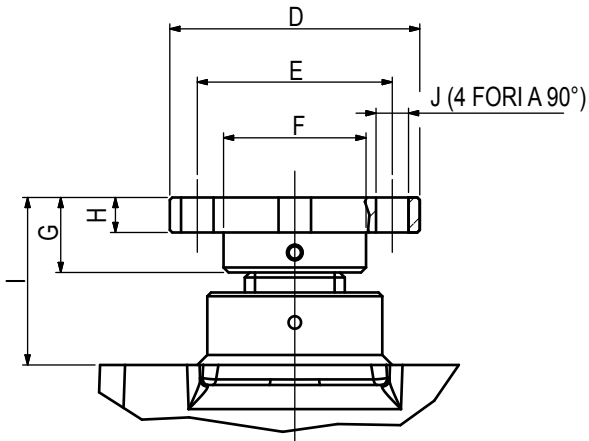

Dimensions table							
Size	D	E	F	G	H	I	J
05	Ø55	Ø40	Ø30	14	8	30.5	Ø7
10	Ø79	Ø60	Ø46	21	8	41	Ø11
25	Ø89	Ø67	Ø46	23	10	49	Ø11
50	Ø109	Ø85	Ø60	30	15	66	Ø13
100	Ø149	Ø117	Ø85	50	20	95	Ø17

### OPTION TA3 - FIXING CLEVIS

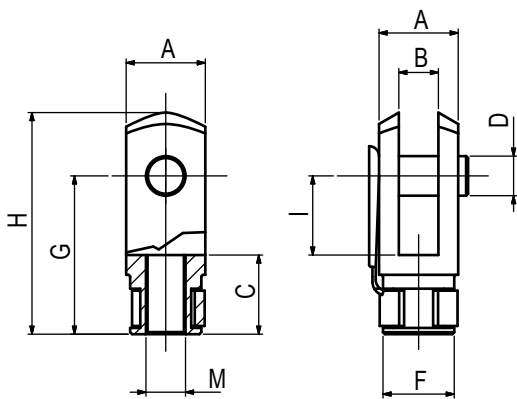

Dimensions table									
Size	A	B	C	D (ØH9)	F	G	H	I	M
05	24	12	24	Ø12	20	48	62	24	M12
10	27	14	28	Ø14	24	56	72	28	M14
25 *	40	20	40	Ø20	34	80	105	40	M20x1.5
50 *	55	30	56	Ø30	48	110	148	54	M27x2
100 *	70	35	72	Ø35	60	144	188	72	M36x2
200 *	120	60	104	Ø60	100	208	268	104	M52x3

From Size 05 to Size 25, clevises integrate pin w/clip.

From Size 50 to Size 200, clevises integrate pin w/seeger.

For Size s marked with (\*) option TA3 needs to be clearly required when ordering, because clips can't be mounted (afterwards) on a standard leadscrew edge.

### OPTION TA4 - FIXING BALL JOINT

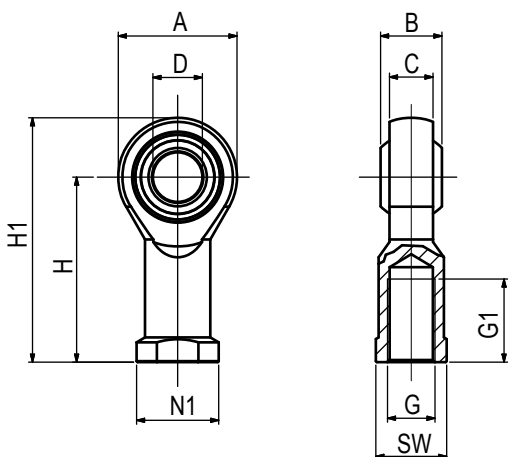

Dimensions table										
Size	A	B	C	D (ØH9)	G	G1	H	H1	N1	SW
05	32	16	12	Ø12	M12	22	50	66	22	19
10	36	19	13.5	Ø15	M14	25	57	75	26	22
25 *	50	25	18	Ø20	M20x1.5	33	77	102	35	30
50	70	37	25	Ø30	M30x2	51	110	145	50	41
100 *	80	43	28	Ø35	M36x2	56	125	165	58	50
200 *	137	44	38	Ø60	M52x3	70	175	243	88	75

Can only be mounted on threads different from standard ones.

## REAR FIXING

### OPTION K - ADDITIONAL GEARBOX HOLE-SETTINGS

There is availability for different hole-settings, by drilling additional threaded holes on gearbox.

Table below shows possibilities for hole-settings, and customized ones can be supplied upon contact to Mecvel offices.

Dimensions table				
Size	A	B	C	D
05	28	56	80	Ø9 THROUGH HOLE
10	30	80	85	M8 DEEP 16
25 *	48	102	131	Ø11 THROUGH HOLE
50	60	130	165	Ø13 THROUGH HOLE
100	60	134	175	M20 DEEP 40

\*already supplied on standard gearbox

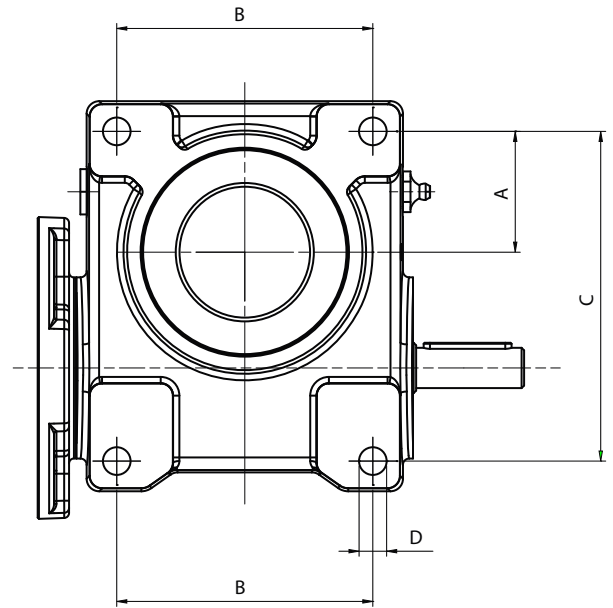

### OPTION LF - FASTENING STRIPS

In case threaded holes on gearbox should not be 100% compatible with customer's structure, additional fastening strips are available.

Table below shows standard strips, but customized ones can be made: contact Mecvel offices to check possibilities in detail.

For more information please contact MecVel's tech department.

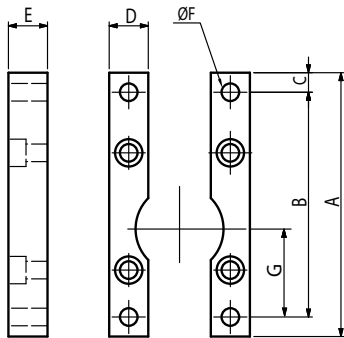

Dimensions table							
Size	A	B	C	D	E	F	G
05	140	120	10	20	15	Ø9	48
10	150	130	10	20	20	Ø9	52
25	210	185	12.5	30	20	Ø11	75
50	270	240	15	40	30	Ø13	98
100	315	275	20	40	40	Ø19	110
200	415	365	25	60	60	Ø28	155

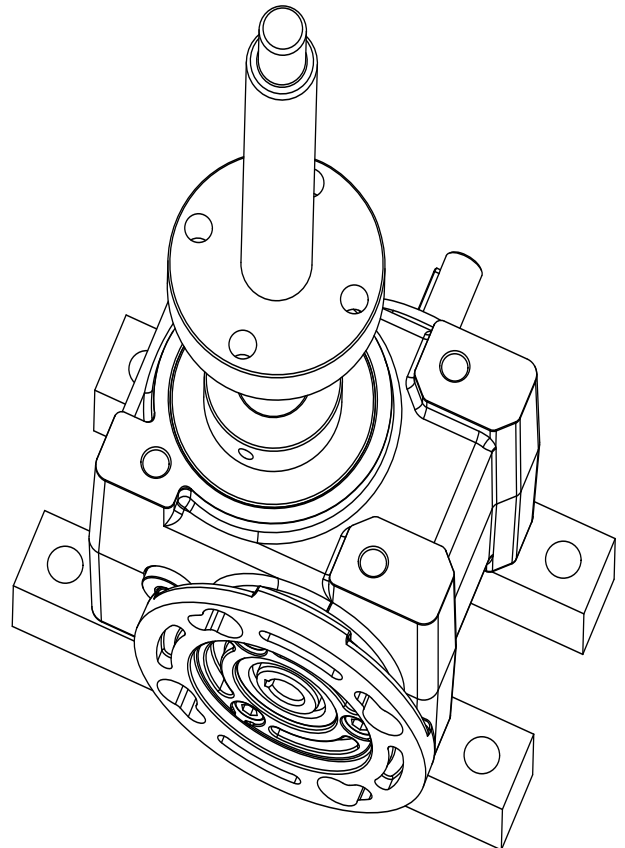



## OPTION OA E OP - ROCKING OPERATION SUPPORTS

Size s 05 / 10 / 25 can host counter-platings for pins, that allow screwjacks for a “swinging” movement when operating  
Table below shows dimensions and mounting specs for these platings.

Swivelling shafts holder for connection to customer’s structure are also available

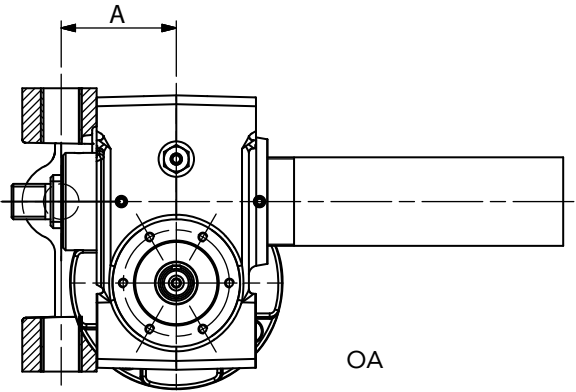
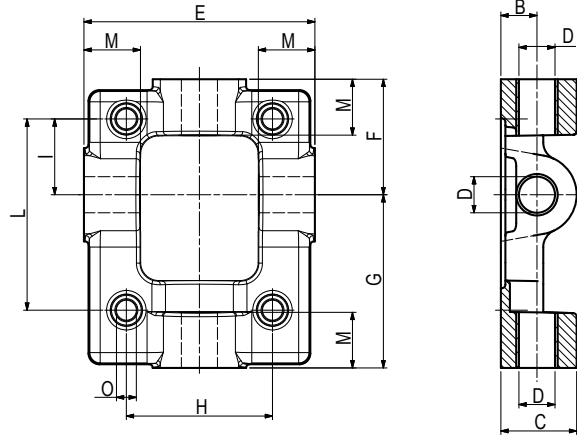
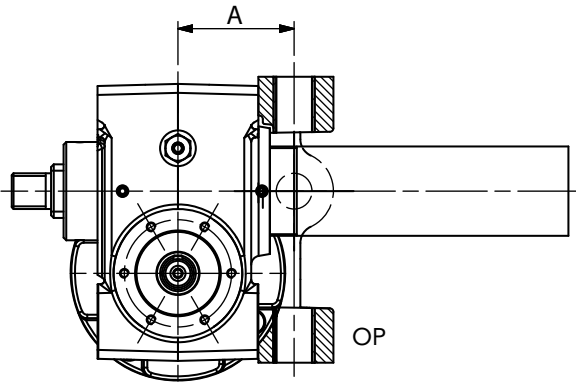

Dimensions table												
Size	A	B	C	D (ØH7)	E	F	G	H	I	L	M	O
05	50	15	29	Ø16	74	37	61	52	21	60	10	Ø9
10	55	15	30	Ø16	104	41	66	62	29	78	15	Ø9
25	65	20	42	Ø20	128	64	96	81	42	106	30	Ø11

## OPTION OP - INTEGRATED ROCKING OPERATION SUPPORTS

Size s 50 / 100 / 200, requested with option OP, are already integrating the pins in their gearboxes, so to allow for the “swinging” movement already described. In these three Size s, option OA is not available.

Swivelling shafts holder for connection to customer’s structure, are also available, except for Size 200.

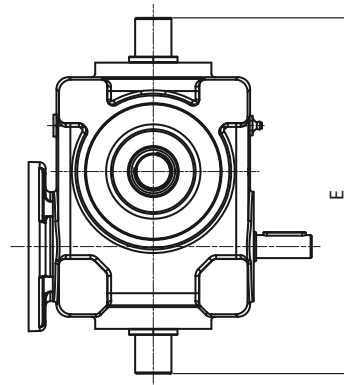
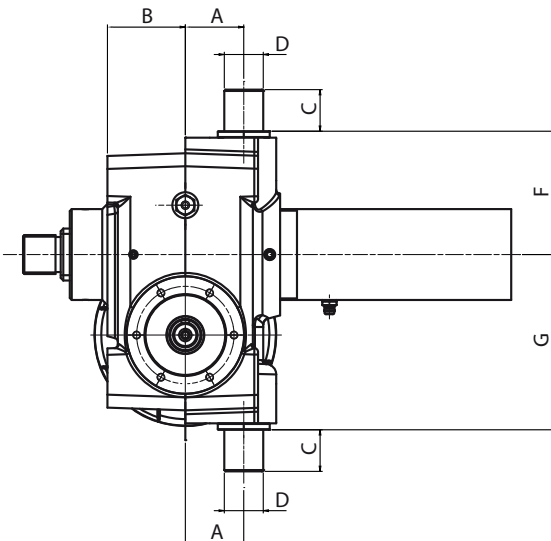

Dimensions table							
Size	A	B	C	D (Øh7)	E	F	G
50	45	63	32	Ø30	294	95	135
100	90	80	42	Ø40	330	97	149
200	45	96	60	Ø55	444	146	178



### SP...P - SWINGING MOUNTING FEET

A practical installation of screwjacks featuring swinging movement support (option OA-OP) can be done thanks to four Sizes of mounting "feet"

SP...P kit includes two feet and two pins.

This option is unavailable for Size 200.

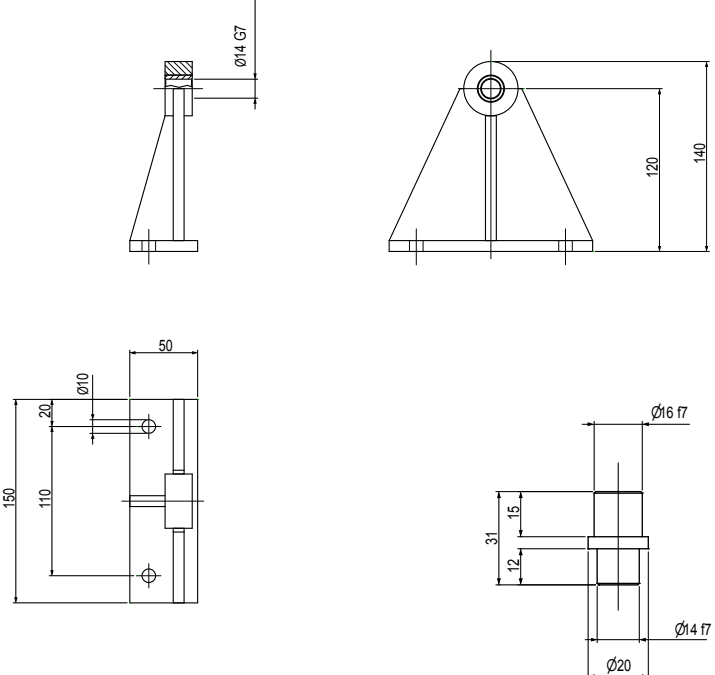
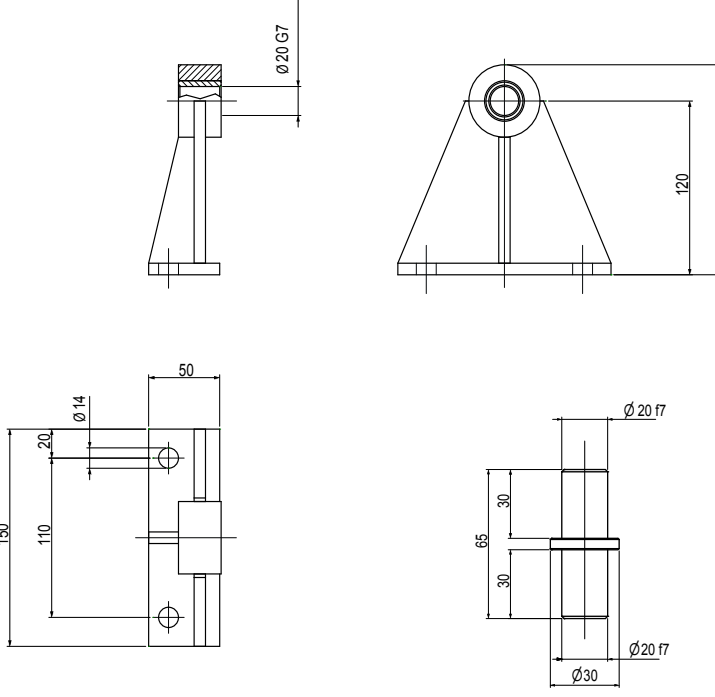
Code	Description	Dimensions
SP0014P	Kit includes two feet and two pins 14/16, for screwjacks Size 05 10	
SP0020P	Kit includes two feet and two pins 20, for screwjacks Size 25	



Code	Description	Dimensions
SP0030P	Kit includes two feet 30, for screwjacks Size 50	<p>Technical drawings for SP0030P showing dimensions:</p> <ul style="list-style-type: none"> <li>Side view: <math>\varnothing 30\ G7</math>, 50</li> <li>Front view: 155, 120</li> <li>Detail view (left): 150, 110, 20, <math>\varnothing 14</math>, 56</li> <li>Detail view (right): <math>\varnothing 30\ f7</math>, 66.5, 32, 29.5, <math>\varnothing 39</math>, <math>\varnothing 30\ f7</math></li> </ul>
SP0040P	Kit includes two feet 40, for screwjacks Size 100	<p>Technical drawings for SP0040P showing dimensions:</p> <ul style="list-style-type: none"> <li>Side view: <math>\varnothing 40\ G7</math>, 70</li> <li>Front view: 205, 160</li> <li>Detail view (left): 260, 200, 30, <math>\varnothing 18</math>, 75</li> <li>Detail view (right): <math>\varnothing 40\ f7</math>, 89, 42, 42, <math>\varnothing 50</math>, <math>\varnothing 40\ f7</math></li> </ul>

## SCREW PROTECTIONS

### OPTION B - BELLOWS BOOT

Leadscrew can be protected by means of this element, a very useful one in case of harsh (dust, rain...) or delicate (food, medical) environments.

#### HT MODEL

Dimensions table					
Size	A	B	C	D	E
05	70	$36 + ((1.16 \times \text{stroke}) - \text{stroke})$	17.5	M12	Ø70
10	80	$40 + ((1.12 \times \text{stroke}) - \text{stroke})$	19	M14	Ø80
25	90	$46 + ((1.08 \times \text{stroke}) - \text{stroke})$	22	M20	Ø105
50	120	$56 + ((1.04 \times \text{stroke}) - \text{stroke})$	29	M30X2	Ø150
100	160	$65 + ((1.05 \times \text{stroke}) - \text{stroke})$	45	M36X3	Ø165
200	192	$70 + ((1.06 \times \text{stroke}) - \text{stroke})$	58	M56X5.5	Ø195

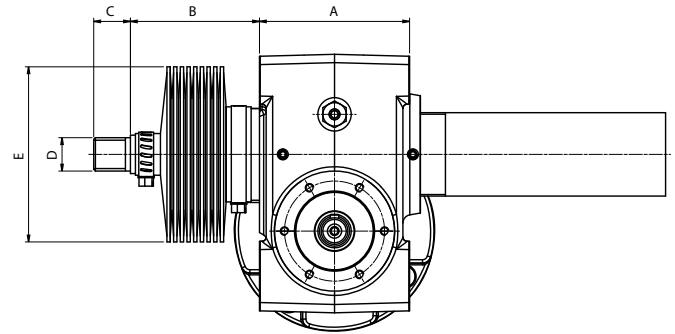

#### HR MODEL

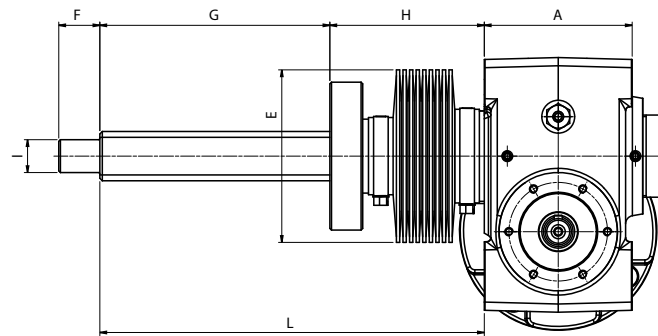

Dimensions table							
Size	A	E	F	G	H	I (Øh7)	L
05	70	Ø70	16	$20 + \text{stroke}$	$47 + ((1.16 \times \text{stroke}) - \text{stroke})$	Ø12	$67 + (1.16 \times \text{stroke})$
10	80	Ø80	20	$25 + \text{stroke}$	$56 + ((1.12 \times \text{stroke}) - \text{stroke})$	Ø15	$81 + (1.12 \times \text{stroke})$
25	90	Ø105	25	$40 + \text{stroke}$	$70 + ((1.08 \times \text{stroke}) - \text{stroke})$	Ø20	$110 + (1.08 \times \text{stroke})$
50	120	Ø150	30	$50 + \text{stroke}$	$100 + ((1.04 \times \text{stroke}) - \text{stroke})$	Ø25	$150 + (1.04 \times \text{stroke})$
100	160	Ø165	40	$55 + \text{stroke}$	$120 + ((1.05 \times \text{stroke}) - \text{stroke})$	Ø40	$175 + (1.05 \times \text{stroke})$
200	192	Ø195	70	$60 + \text{stroke}$	$145 + ((1.06 \times \text{stroke}) - \text{stroke})$	Ø55	$205 + (1.06 \times \text{stroke})$

On demand double bellows boot on HR screwjacks.



### OPTION PO - REAR-PIPE FOR SWINGING MOVEMENT (ONLY HT MODEL)

In case an eyelet rear attachment is needed, screwjacks can be fitted with this type of rear-pipe. When using this kind of fastening, rear-pipe is undertaking max load applied to screwjack

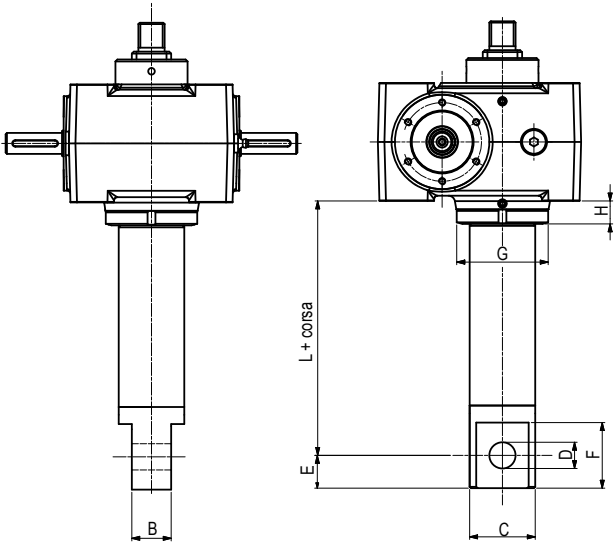

Dimensions table								
Size	B	C	D (ØH7)	E	F	G	H	L
05	25	Ø36	Ø20	20	40	Ø42	12	92
10	25	Ø36	Ø20	20	40	Ø42	11	92
25	30	Ø50	Ø25	25	50	Ø70	18	120
50	40	Ø70	Ø35	35	70	Ø92	24	152
100	60	Ø85	Ø50	50	100	Ø110	37	210
200	75	Ø120	Ø60	60	120	Ø155	43	240

### OPTION - FIXED PROTECTION (ONLY HT MODEL)

For the HT version is available for the fixed protection in aluminum for the leadscrew. Mandatory accessory with inductive limit switches (FCI), magnetic limit switches (FCM), mechanical limit switches (FCE) and anti-rotation device (option L). If not interested in the protection, include "C" in the ordering key.

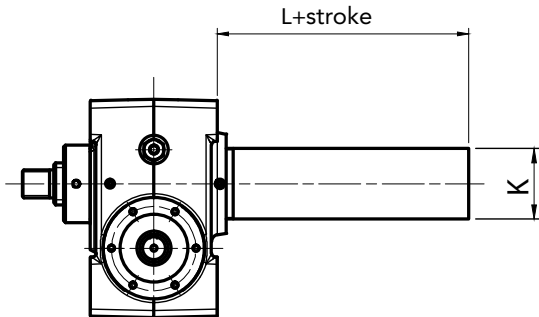

Dimensions table		
Size	L	K
05	55	Ø36
10	52	Ø36
25	74	Ø50
50	91	Ø70
100	126	Ø85
200	137	Ø120

### OPTION L - ANTIROTATION DEVICE

The Anti-rotation device avoids push rod spinning around its own axis when travelling: it is essential in case of not guided load. When using TA3 and A4 front ends it is advisable to use this option to prevent front end from unscrewing in case it is not properly fixed.

This device is available only on travelling screw models HT and it is done by means of a flanged nut fixed on the bottom of the acme screw engaged in a keyway fixed to the protective tube.

#### VERSION FOR SIZE S HT 05 10 25

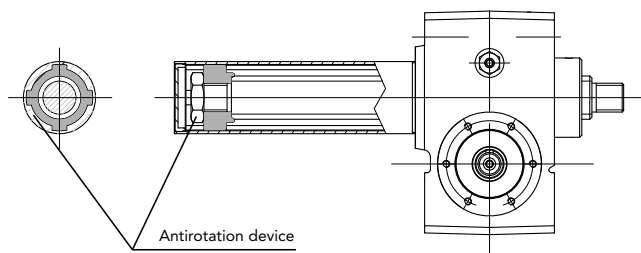

#### VERSION FOR SIZE S HT 50 100 200

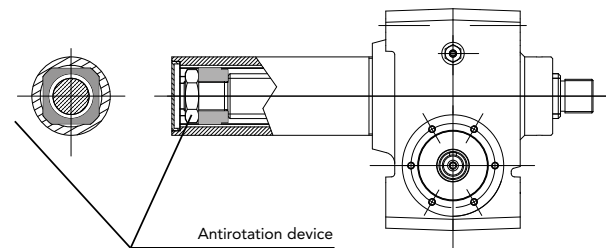

## SAFETY NUTS

In some applications it is necessary to have the jack hold the load even in the event that the main nut fails due to wear. The safety nut is a device that enables checking the wear of the main nut and that prevents the load from falling down in case the nut thread collapses, due to wear, before being able to do the necessary checking operations. Three types of safety nuts are available for acme screwjacks, according to the specific needs of each application. For ball screwjacks we can supply similar solutions but it is necessary to contact our technical department.

### OPTION GS - STEEL SAFETY NUT (ONLY FOR TRAVELLING NUT MODELS HR)

The safety nut is in steel and has been designed to start working only in case of main nut maximum wear. This safety nut is connected to the main bronze nut and travels with it along the stroke. When the bronze nut is completely worn out, the steel nut starts working on acme screw until it comes to a complete grip to acme screw. Screwjack is the completely blocked. This kind of nut can work in both directions, i.e. with compression or traction load (pushing / pulling)

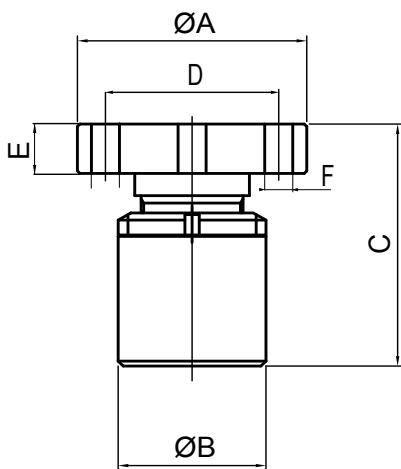

Dimensions table					
Size	A	B	C	L	Tr
05	Ø55	Ø45	65	76	18x4
10	Ø65	Ø45	65	86	20x4
25	Ø90	Ø58	95	125	30x6
50	Ø99	Ø75	135	165	40x7
100	Ø129	Ø92	170	200	55x9
200	Ø179	Ø125	200	230	70x10

Compression-Pushing load

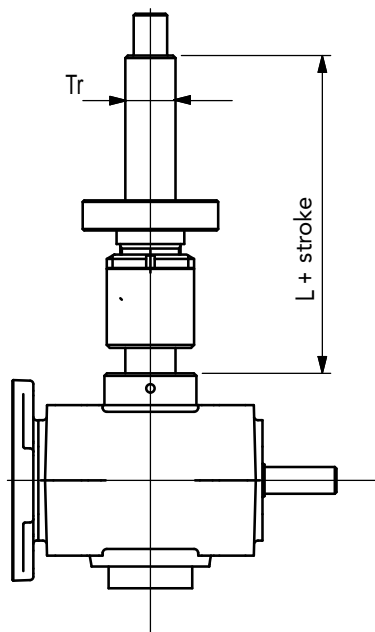

Traction-Pulling load

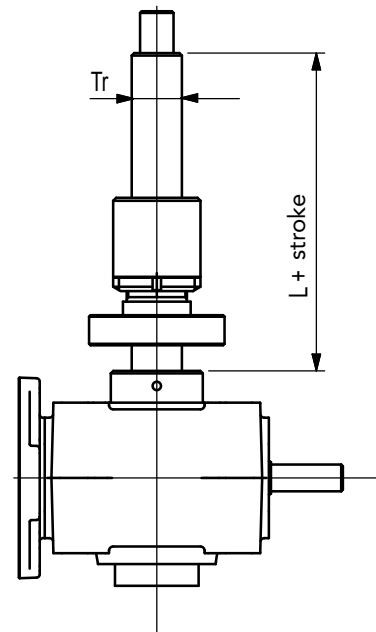



### OPTION G - BRONZE SAFETY NUT WITH VISUAL WEAR CECK (ONLY HR MODELS)

An auxiliary bronze nut travels along with main bronze nut, kept together by a small slot.

This connection allows for independent axial movement of one nut to the other. When main nut starts getting too much worn, backlash between this nut and leadscrew grows. This condition causes the auxiliary nut to start working, undertaking part of the load.

When this happens, dimension "X" (see table below) lowers; and once it reaches the minimum admitted value shown below, screwjack shall be serviced because wear has reached a critical level, causing a possible collapse of load. Therefore, we recommend a recurrent check of "X", so to monitor wear of system.

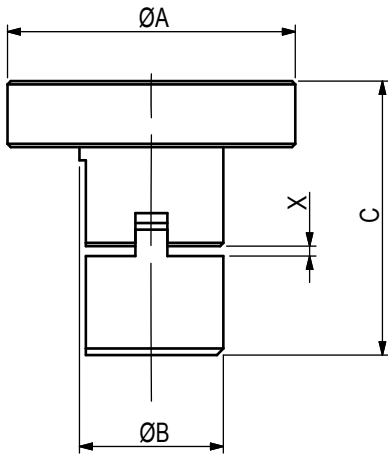

Dimensions table							
Size	A	B	C	L	Starting value X	Minimum admitted value X	Tr
05	Ø55	Ø30	55	76	2	1	18x4
10	Ø65	Ø35	62	86	2	1	20x4
25	Ø90	Ø45	83	125	3	1.5	30x6
50	Ø99	Ø57	114	165	3.5	1.75	40x7
100	Ø129	Ø72	145	200	4.5	2.25	55x9
200	Ø179	Ø100	170	230	5	2.5	70x10

Compression-Pushing load

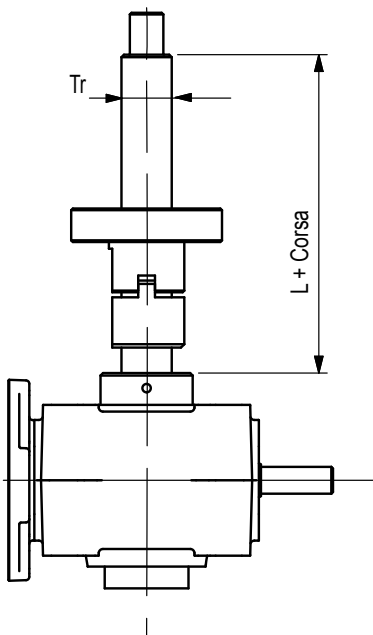

Traction-Pulling load

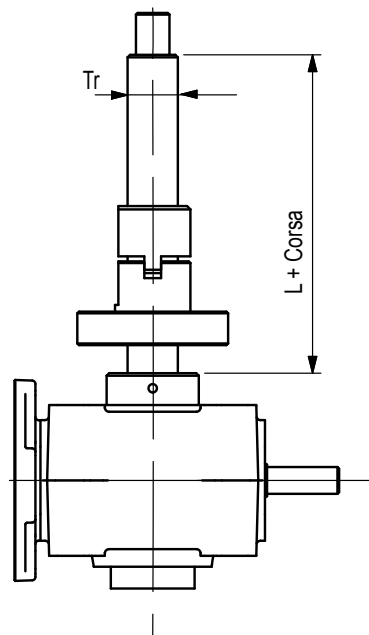

**OPTION GU - BRONZE SAFETY NUT, WITH AUTOMATIC AND VISUAL WEAR CHECK (ONLY HR MODEL)**

This system works as previous one (Option "G"): it only differs for the proximity sensor installed, which will provide a signal when wear reaches a critical level.

Dimensions table						
Size	A	B	C	D	L	Tr
05	Ø55	Ø30	55	43	96	18x4
10	Ø65	Ø35	62	50	106	20x4
25	Ø90	Ø45	83	68	145	30x6
50	Ø99	Ø57	114	78	185	40x7
100	Ø129	Ø72	145	100	220	55x9
200	Ø179	Ø100	170	140	250	70x10

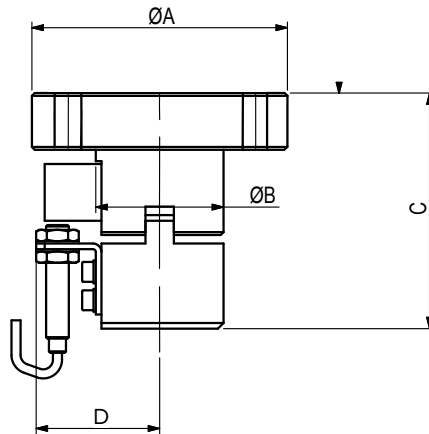

Compression-Pushing load

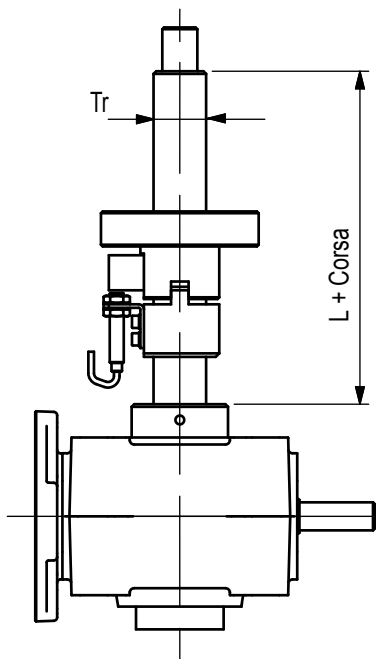

Traction-Pulling load

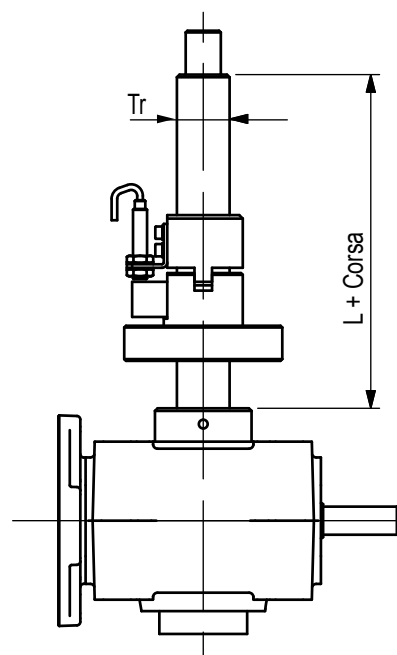



### OPTION GU - BRONZE SAFETY NUT WITH WEAR AUTOMATIC CONTROL (ONLY HT MODEL)

It is made with a second nut, coupled to the main nut with 4 pins that ensure the rotation, but left free to move axially with respect to the other. When the nut begins to wear, the clearance between the nut and the screw increases causing variations in the distance between nut and safety nut. When this distance reaches the maximum limit the inductive sensor shall signal reaching of the maximum allowable wear of the nut. When the sensor gives the alarm it is absolutely necessary to replace the nut and safety nut.

Failure to replace these components may lead to excessive wear such as to cause the collapse of the load.

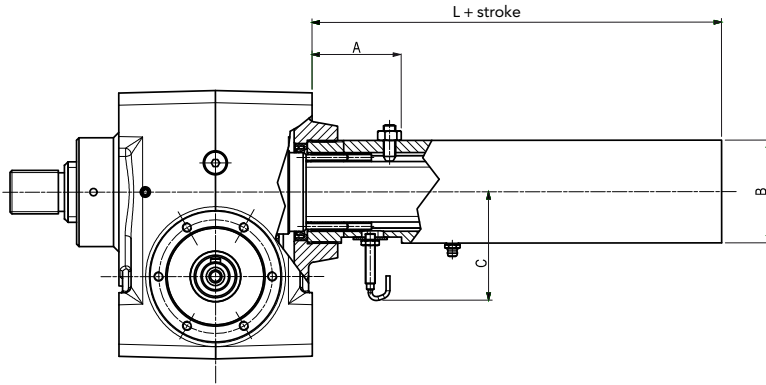

Dimensions table				
Size	A	B	C	L
25	50	50	75	134
50	60	70	85	116
100	75	85	90	146
200	85	120	110	172

### OPTION U - DOUBLE SCREW WITH RIGHT AND LEFT THREAD

Sulle versioni HR e HR-VRS può essere applicata al martinetto una doppia asta (una dx e una sx) con le relative chiocciole. Le Features prestazionali restano le medesime dei martinetti ad un solo stelo.

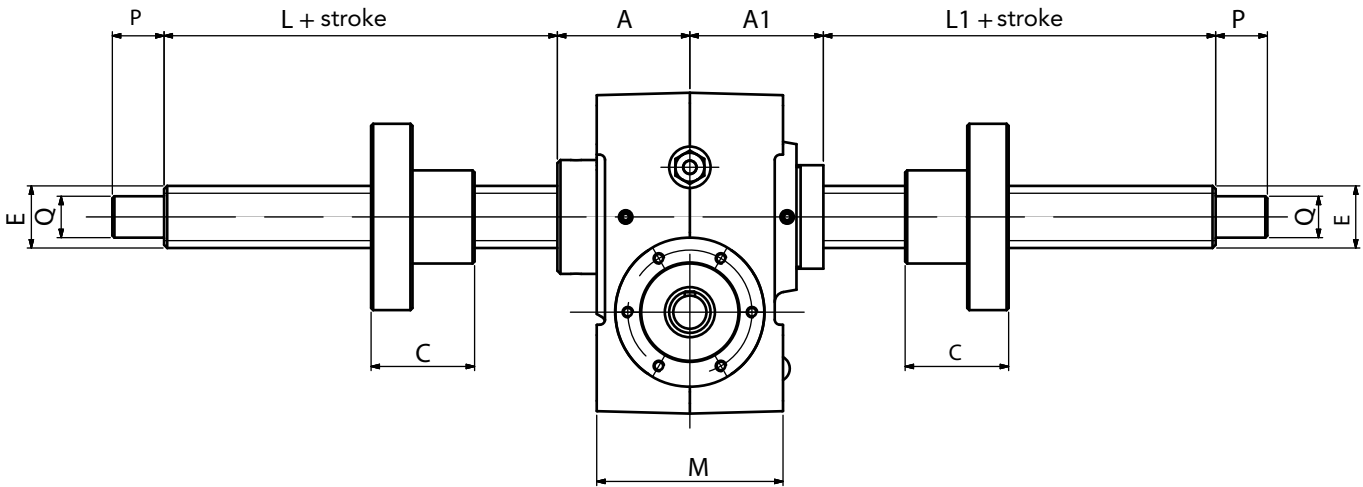

Dimensions									
Size	A	A1	C	E	M	L	L1	P	Q(øh7)
HR 05	45.5	54.5	35	TR 18X4	70	65	56	16	Ø12
HR 10	55	59	40	TR 20X4	80	66	62	20	Ø15
HR 25	64	64	50	TR 30X6	90	90	90	25	Ø20
HR 50	89	93	70	TR 40X7	120	120	116	30	Ø25
HR 100	115	131	85	TR 55X9	160	140	124	40	Ø40
HR 200	136	143	105	TR 70X10	192	165	158	70	Ø55



### OPTION V - SCREWJACKS WITH INCREASED SIZE OF SCREW (ONLY ON HR AND HR-VRS MODELS)

In case of applications where the static conditions are more demanding than the working dynamic ones (long strokes with heavy push loads or short strokes with even higher push loads) it is possible to manufacture screwjacks with increased size screws or ballscrew. Our Technical Dept. is at customer's disposal for assistance in rising systems selection.

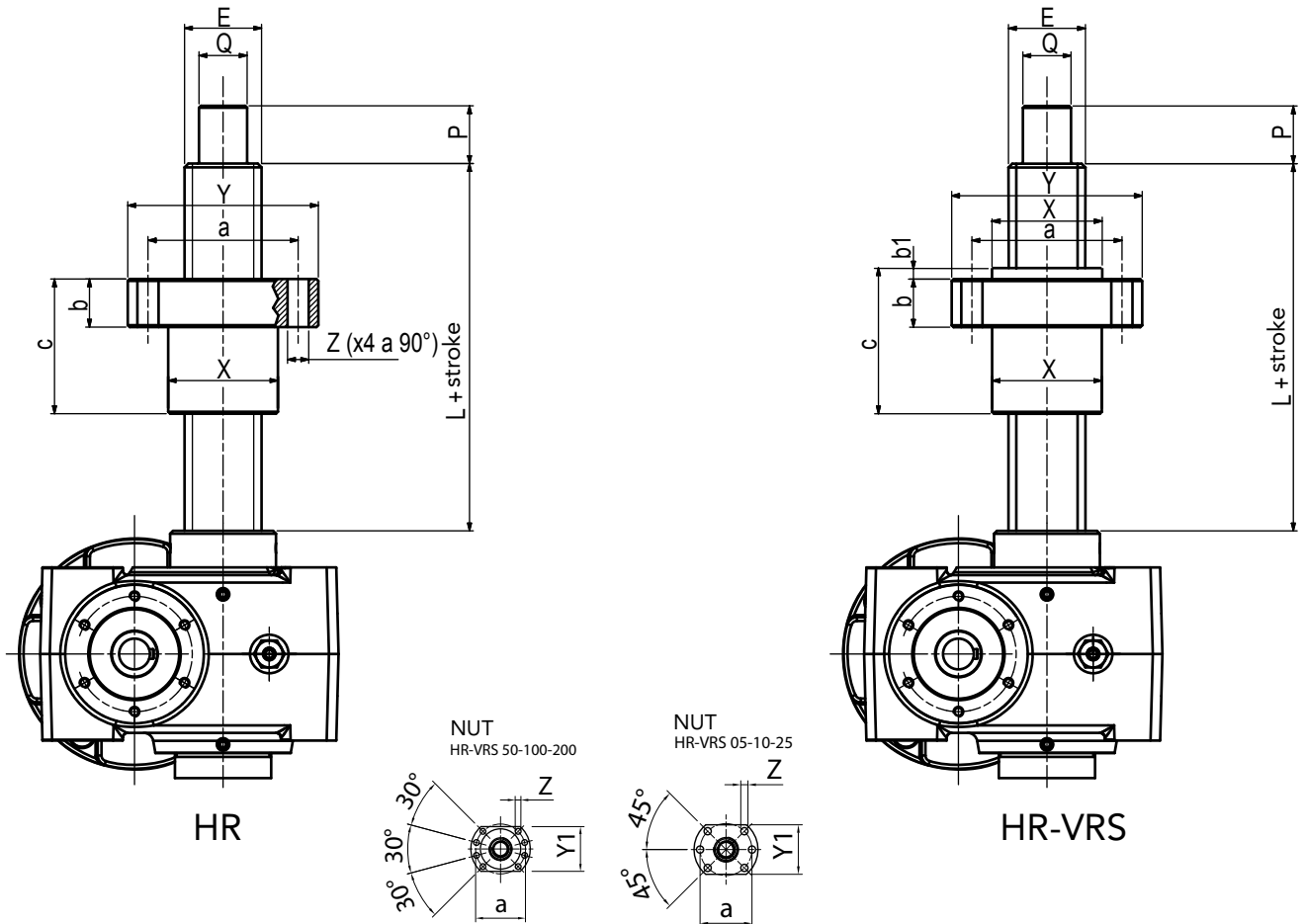

Dimensions												
Size	E	P	Q (Øh7)	X	Y	Y1	Z	a	b	b1	c	L
HR 05	TR 20x04	20	Ø15	Ø35	Ø65		9	Ø50	15		40	66
HR 10	TR 30x6	25	Ø20	Ø45	Ø90		11	Ø68	20		50	90
HR 25	TR 40x7	30	Ø25	Ø57	Ø99		11	Ø78	25		70	120
HR 50	TR 55x9	40	Ø40	Ø72	Ø129		13	Ø100	30		85	140
HR 100	TR 70x10	70	Ø55	Ø100	Ø179		18	Ø140	30		105	165
HR 200	TR 80x10	75	Ø60	Ø110	Ø189		18	Ø150	30		110	170
HR-VRS 05	VRS 20X5	20	Ø15	Ø36	Ø58	44	6.5	Ø47	10	5	55	91
HR-VRS 10	VRS 32X10	25	Ø20	Ø50	Ø80	62	9	Ø65	12	6	118	155
HR-VRS 25	VRS 40X10	30	Ø25	Ø63	Ø93	70	9	Ø78	14	7	142	190
HR-VRS 50	VRS 50X10	40	Ø40	Ø75	Ø110	85	11	Ø93	16	7	144	200
HR-VRS 100	VRS 63X10	70	Ø55	Ø90	Ø125	95	11	Ø108	18	7	166	225
HR-VRS 200	VRS 80X10	75	Ø60	Ø105	Ø145	110	13.5	Ø125	20	9	172	235



## INPUT OPTIONS

### OPTION H - HANDWHEEL FOR MANUAL DRIVING

Screwjacks can be manually driven via a handwheel, installed on its outcoming shafts, or on aux shaft of electric motor. Depending on reduction ratio and leadscrew pitch, running a complete stroke with manual winding might require a large amount of rotations.

Handwheel specs are shown in table below.

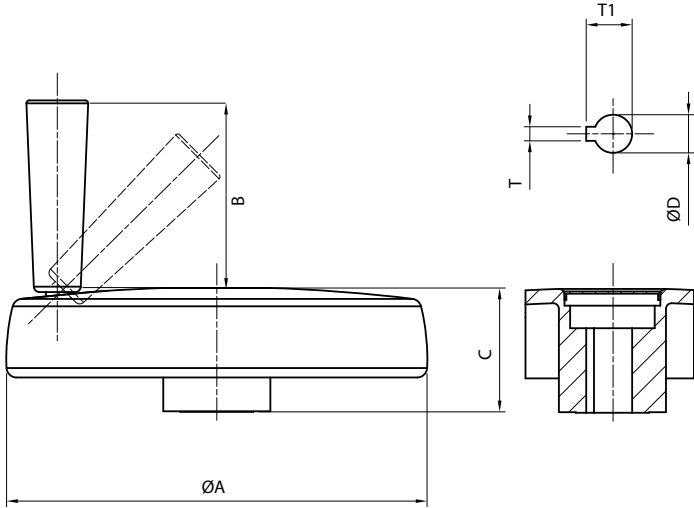

Dimensions table						
Size	A	B	C	D	T	T1
05	Ø102	50	34	Ø10	3	11.4
10	Ø150	65	44	Ø14	5	16.3
25	Ø176	80	49	Ø16	5	18.3
50	Ø200	90	53	Ø19	6	21.8
100	Ø200	90	53	Ø24	8	27.3
200	Ø250	90	66	Ø30	8	33.3

### MOTOR CONNECTION

Direct motor connection via motorflange + hollowshaft. Motor is directly linked to screwjack, with an IEC motorflange. Table below shows dimensions for available motofl anges on each size. Size 200 can't provide direct motorconnection via flange.

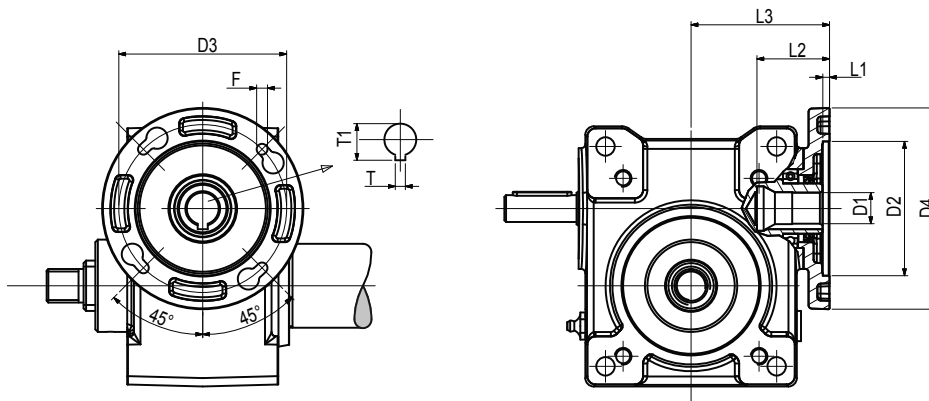

Dimensions table														
Size	D1	D2	D3	D4	F	L1	L2	L3					T	T1
								HT/ HR 05	HT/ HR 10	HT/ HR 25	HT/ HR 50	HT/HR 100		
56 B14	Ø9	Ø50	Ø65	Ø80	Ø5.5	3	22	52					3	10.4
63 B14	Ø11	Ø60	Ø75	Ø90	Ø5.5	3.5	25	52	65.5				4	12.8
71 B14	Ø14	Ø70	Ø85	Ø105	Ø6.5	4	35		65.5	82.5			5	16.3
80 B14	Ø19	Ø80	Ø100	Ø120	Ø6.5	4	42			82.5	103		6	21.8
90 B14	Ø24	Ø95	Ø115	Ø140	Ø8.5	4.5	53				103		8	27.3
100/112 B14	Ø28	Ø110	Ø130	Ø160	Ø8.5	4.5	64					112.5	8	31.3

### OPTION CG - MOTOR CONNECTION, WITH BELL-FLANGE AND COUPLING

Sizes 50 / 100 / 200 feature also the "bellflange + coupling" motor connection.  
See table below for dimensions and specifications.

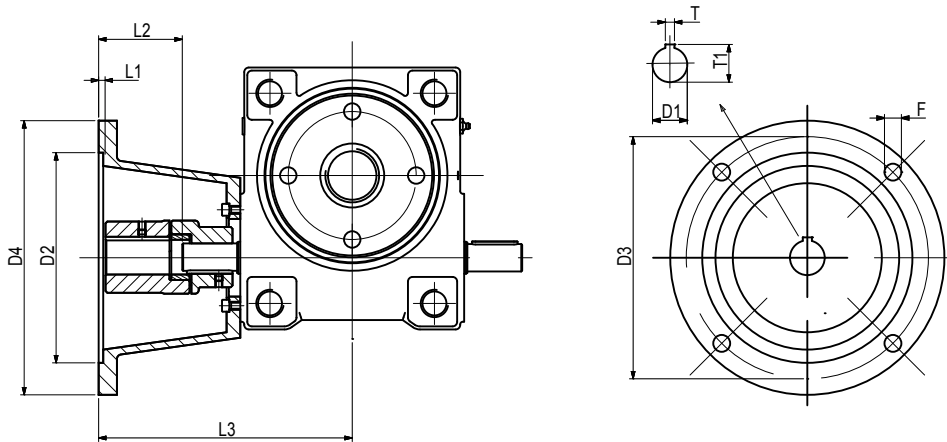

Dimensions table

Size	D1	D2	D3	D4	F	L1	L2	L3			T	T1
								HT/HR	HT/HR	HT/HR		
								50	100	200		
80 B5	Ø19	Ø130	Ø165	Ø200	M10	4.5	52	183			6	21.8
90 B5	Ø24	Ø130	Ø165	Ø200	M10	4.5	52	183			8	27.3
100/112 B5	Ø28	Ø180	Ø215	Ø250	f14.5	5	68		239	259	8	31.3
132 B5	Ø38	Ø230	Ø265	Ø300	f14.5	5	91		274	278	10	41.3



## E-BOX

### HT/HR-M MODEL

For HT/HR screwjack complete with motor write in the ordering key the e-box position.  
For the right motor choice check the following page or contact MecVel's staff.

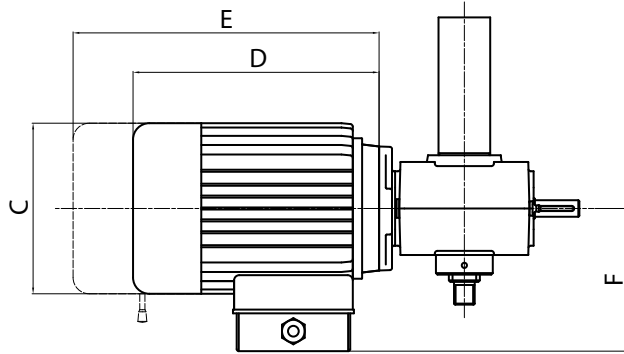

### E-BOX POSITION

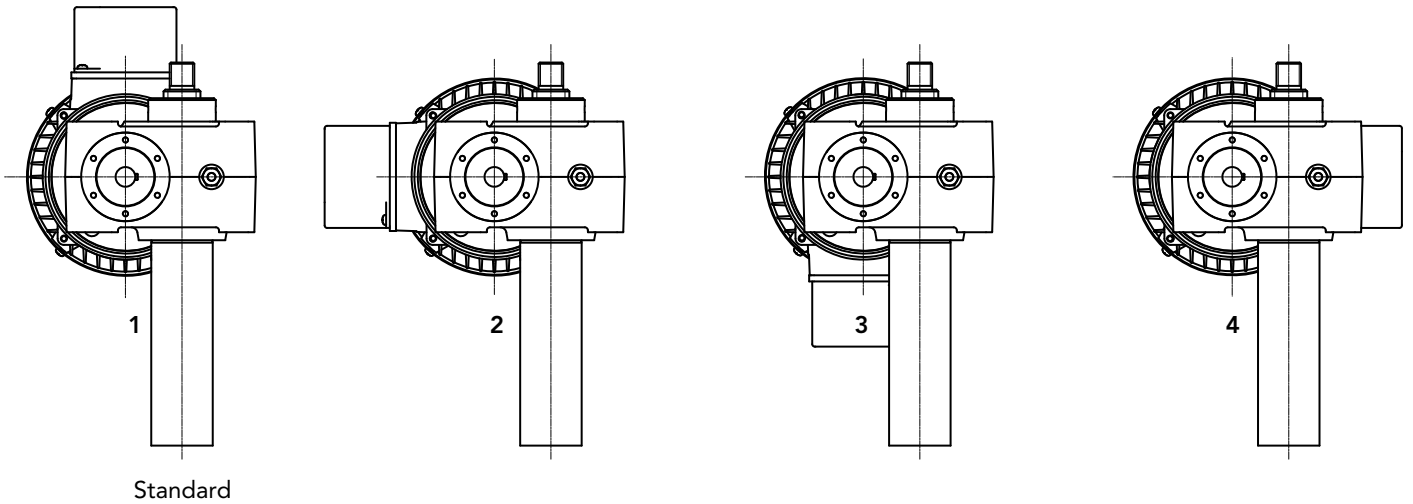

### ORIENTATION OF MOTOR FLANGES AND SHAFTS

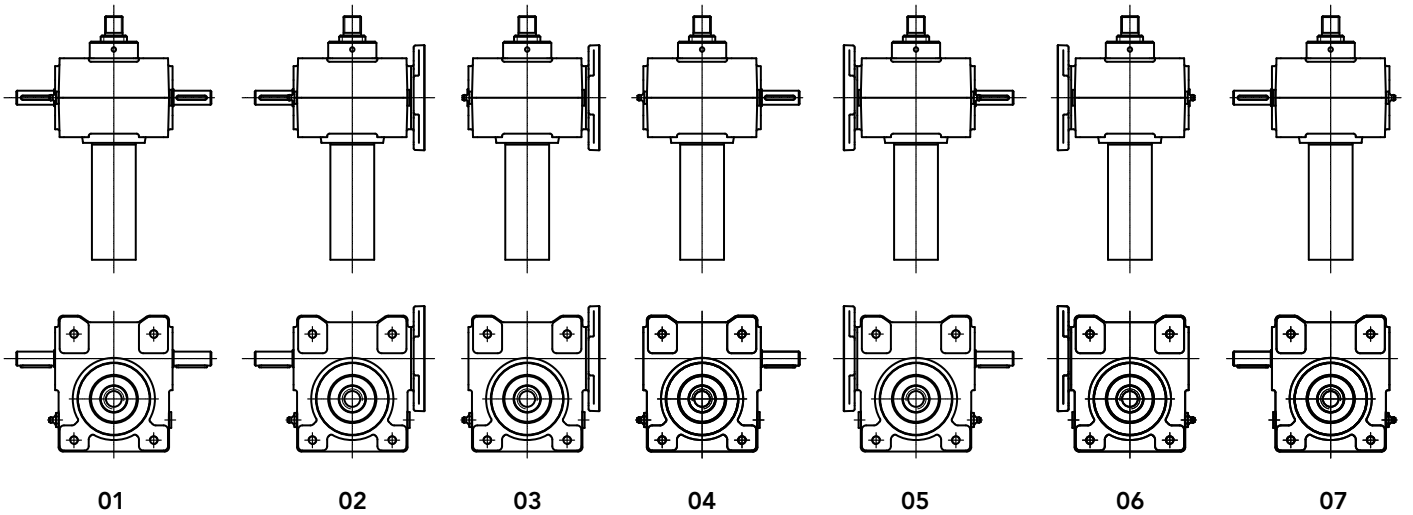

## MOTOR CHOICE GUIDELINES

### MOTOR TYPE

Version	AC PD	alternate current special motorflange (provide drawing)
Voltage	AC MT	standard voltage table Multitension 230/50 (1-phase)
Type (Only for AC)	T M AT AM	3-phase 1-phase 3-phase with brake 1-phase with brake
Size	CA	IEC 56/63/71/80/90/100/112/132
N°Poles	CA	2 / 4 / 6

Standard voltage table		
Rated voltage [V] [Hz]		Usable voltage [V] [Hz]
230/400/50	277/480/60	240/415/50 - 220/380/50 - 265/460/60 - 255/440/60
190/330/50	220/380/60	200/346/60 - 208/360/60 - 230/400/60
208/360/50	254/440/60	200/346/50 - 240/415/60
400/690/50	480/830/60	380/660/50 - 415/717/50

### AC MOTOR OPTIONS

Motorflange type:	IEC56B14 / IEC63B14 / IEC71B14 / IEC80 B14 / IEC90 B14 / IEC100/112 B14	
Service rate:	S3 - 30%	standard
Insulation class:	F	standard Advise only if different
Protection degree:	IP55 IP65 IP54 TP IN OTHER NONE	standard on request for selfbraking motors tropicalization winding for inverter advise leave balnk

### MOTOR CONNECTIONS

3-phase motor

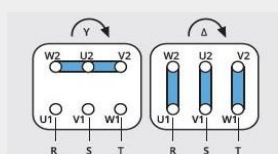

3-phase brakemotor (AC)  
- with power supply

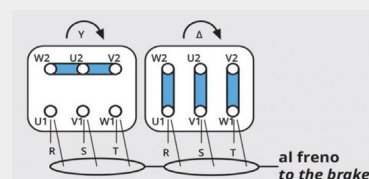



### 3-phase selfbraking motor (AC)

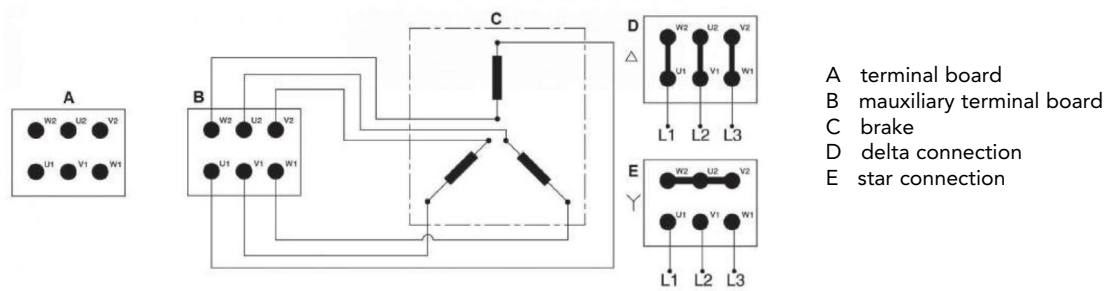

### Freno

#### FECC (standard)

DC brake negative action, available both 1-phase and 3-phase  
Power supply - 230V 10% 50/60Hz AC side inside the brake.

The brake is powered directly from power of the motor (standard)

FECC brake, when compared to an AC brake, has longer response times, but it is less noisy  
Si può ottenere una frenatura rapida utilizzando un opportuno raddrizzatore.

Motors with separated brake power supply and tensions in the range (24-205 Vdc) can be available on request. In this case the brake needs a separated power supply from the motor and its code becomes FECC-AS-24 Vdc

#### FECA

AC brake, available only for 3-phase motors, sizes IEC 63 or above  
Power supply - = 230V (trifase) ± 10% 50/60 Hz.

The brake is powered directly from the power supply of the motor.

FECA brake has a faster response time than a DC brake, but it is noisier.

It is the right choice when the brake intervenes very often and the braking torque requested value is high.

Motors with separated brake power supply and tensions in the range (24-690 Vac - 50/60 Hz) can be available on request. In this case the brake needs a separated power supply from the motor and its code becomes FECA-AS-230 Vac 50 HZ

*Separate power supply:* achieved by means of an auxiliary terminal board, with fixed brake coil terminals, located inside the motor terminal box.

Note: On all motors prepared for frequency converter the brake must always have a separate power supply

WITHOUT      leave blank

### Options

- LS                      hand release lever (leave blank)
- Note                    not available for motor IEC 56
- AB                      2'shaft
- IN                       winding suitable for inverters
- OTHER                advise in detail
- NONE                    without



MecVel reserves the right to change products information and/or features without notice; all data contained in this catalogue are purely indicative and not binding for the company.

## EXAMPLE OF ORDERING KEY

HT25-FCI/0250/1:10+4/CA-400-50-T-71-4-0.37/S3+IP65+AB/02/1/E05/2FCI/POTO1A/FCI1/IP65/SF/B+C+H/N.DIS.

<p>MODE _____ HT / HR</p> <p>Stroke es. 250 mm = 0250</p> <p>REDUCTION RATIOS + PITCH Version PAM, PD , Mechanical: 1:4 / 1:5 / 1:10 / 1:16 / 1:30 + 4 / 6 / 7 / 9 /10 (HT/HR) + 5 / 10 (HT/HR-VRS) SPEED (Motor version only)</p> <p>MOTOR _____ Advise only if with motor: In A.C. version, voltage, type, size, n pole, power In D.C. version, voltage, size, Rpm With motorflange only put 0 With special motorflange put: PD</p> <p>AC MOTOR OPTIONS _____ Motorflange: for motorflange version only advise size - i.e.for IEC56 B14 put 56B14 No motor or DC motor: <i>leave all following parameters blank</i> Service rate Advise if different than S3 (std) Insulation class Advise if different than F (std) Protection Degree Advise if different than IP55 (std) Brake type for brakemotors only: ES. FECA Options Advise if needed (ES. AB 2'shaft)</p> <p>MOTORFLANGE SIDE (PAM) AND IMPUTSHAFTS MODE _____ None : Leave blank</p> <p>E-BOX POSITION _____ 1 (Standard), 2, 3, 4 No Motor or DC motor: leave blank</p> <p>ENCODER _____ None : Leave blank</p> <p>LIMIT SWITCHES _____ None : Leave blank</p> <p>POTETIOMETER _____ None : Leave blank (only version HR-F)</p> <p>STROKE CONTROL POSITION _____ None : Leave blank</p> <p>PROTECTION CLASS _____ IP55 HT IP55 HR (Standard): leave blank IP 65 HT version only with Bellows Boot</p> <p>FRONT FIXINGS _____</p> <table border="0" style="width: 100%;"> <tr> <td>SF Treaded end (standard)</td> <td>TF Fixing Flanged (HT version)</td> </tr> <tr> <td>TS1 Not Standard Eyeled 90 (HT version)</td> <td>TS0 Not Standard Eyeled (HT version)</td> </tr> <tr> <td>TFS Not Standard Fixing Flanged (HT version)</td> <td>TA3 Fixing Clevis (HT version)</td> </tr> <tr> <td>T0 Fixing Eyeled (HT version)</td> <td>TA4 Fixing Ball Joint (HT version)</td> </tr> <tr> <td>T1 Fixing Eyeled turned by 90 (HT version)</td> <td>A9 Special (provide drawing)</td> </tr> </table> <p>OPTIONS _____ NONE: leave blank For the screw jack version without the protection tube, indicate C</p> <p>VARIATIONS _____ Drawing number: Presence of not standard options None: leave blank</p>	SF Treaded end (standard)	TF Fixing Flanged (HT version)	TS1 Not Standard Eyeled 90 (HT version)	TS0 Not Standard Eyeled (HT version)	TFS Not Standard Fixing Flanged (HT version)	TA3 Fixing Clevis (HT version)	T0 Fixing Eyeled (HT version)	TA4 Fixing Ball Joint (HT version)	T1 Fixing Eyeled turned by 90 (HT version)	A9 Special (provide drawing)	
SF Treaded end (standard)	TF Fixing Flanged (HT version)										
TS1 Not Standard Eyeled 90 (HT version)	TS0 Not Standard Eyeled (HT version)										
TFS Not Standard Fixing Flanged (HT version)	TA3 Fixing Clevis (HT version)										
T0 Fixing Eyeled (HT version)	TA4 Fixing Ball Joint (HT version)										
T1 Fixing Eyeled turned by 90 (HT version)	A9 Special (provide drawing)										



## MODELS

HT05 / HT10 / HT25 / HT50 / HT100 / HT200  
HTM05 / HTM10 / HTM25 / HTM50 / HTM100 / HTM200  
HT25-VRS / HT50-VRS / HT100-VRS / HT200-VRS  
HTM05-VRS / HTM10-VRS / HTM25-VRS / HTM50-VRS / HTM100-VRS / HTM200-VRS  
HT05-FCE / HT10-FCE / HT25-FCE / HT50-FCE / HT100-FCE / HT200-FCE  
HTM05-FCE / HTM10-FCE / HTM25-FCE / HTM50-FCE / HTM100-FCE / HTM200-FCE  
HT25-FCE-VRS / HT50-FCE-VRS / HT100-FCE-VRS / HT200-FCE-VRS  
HTM05-FCE-VRS / HTM10-FCE-VRS / HTM25-FCE-VRS / HTM50-FCE-VRS / HTM100-FCE-VRS / HTM200-FCE-VRS  
HT05-FCI / HT10-FCI / HT25-FCI / HT50-FCI / HT100-FCI / HT200-FCI  
HTM05-FCI / HTM10-FCI / HTM25-FCI / HTM50-FCI / HTM100-FCI / HTM200-FCI  
HT25-FCI-VRS / HT50-FCI-VRS / HT100-FCI-VRS / HT200-FCI-VRS  
HTM05-FCI-VRS / HTM10-FCI-VRS / HTM25-FCI-VRS / HTM50-FCI-VRS / HTM100-FCI-VRS / HTM200-FCI-VRS  
HT05-FCM / HT10-FCM / HT25-FCM / HT50-FCM / HT100-FCM / HT200-FCM  
HTM05-FCM / HTM10-FCM / HTM25-FCM / HTM50-FCM / HTM100-FCM / HTM200-FCM  
HT25-FCM-VRS / HT50-FCM-VRS / HT100-FCM-VRS / HT200-FCM-VRS  
HTM05-FCM-VRS / HTM10-FCM-VRS / HTM25-FCM-VRS / HTM50-FCM-VRS / HTM100-FCM-VRS / HTM200-FCM-VRS

HR05 / HR10 / HR25 / HR50 / HR100 / HR200  
HRM05 / HRM10 / HRM25 / HRM50 / HRM100 / HRM200  
HR05-VRS / HR10-VRS / HR25-VRS / HR50-VRS / HR100-VRS / HR200-VRS  
HRM05-VRS / HRM10-VRS / HRM25-VRS / HRM50-VRS / HRM100-VRS / HRM200-VRS  
HR05-F / HR10-F / HR25-F / HR50-F / HR100-F /  
HRM05-F / HRM10-F / HRM25-F / HRM50-F / HRM100-F  
HR05-F-VRS / HR10-F-VRS / HR25-F-VRS / HR50-F-VRS / HR100-F-VRS  
HRM05-F-VRS / HRM10-F-VRS / HRM25-F-VRS / HRM50-F-VRS / HRM100-F-VRS

Stroke control model (page 27)

FCM	Magnetic limit swithes
FCI	Inductive sensor
F	Integrated limit switches

## OPTIONS

A	Stainless Steel version
B	Bellows boot
C	No rear tube (HT) (don't write "C" if you want the rear tube)
CG	Bellflange with coupling
E	Silicon seals
FF	Standard Painting (blue)
FA	Painting (milder but more elastic than the standard painting)
FM	Marine type Painting (5 layers)
FX	Painting
G	Safety nut (HR/HR-F)
GS	Steel safety nut (HR/HR-F)
GU	Safety ut with wear control sensor (HR/HR-F)
H	Handwheel
K	Special fixing holes on jack's body (HT/HR 25)
IA	Automatic greaser
L	Anti rotation device (HT)
LF	Fastening strips
M	2 guide (for stroke 20 times larger than lead screw) (HT)
O	Body Integrated Swivelling shafts (HT/HR 50 100 200)
OA	Front Swivelling plate (HT 05 10 25 HR 05 10 25)
OP	Rear Swivelling plate (HT 05 10 25 HR 05 10 25)
PO	Rear-pipe for swinging movement (HT)
Q	Without nut (HR)
R	Oil lubricated
S	Limitatore di Torque
U	Double screw with rh and lh thread (HR)
V	Increased size screw (HR/HR-F)



## COUPLINGS

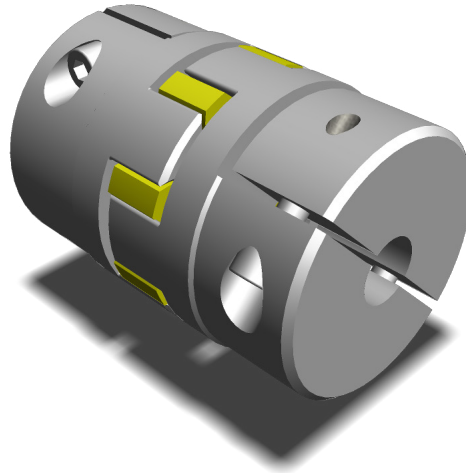

### STANDARD COUPLINGS G

Main feature of this type of coupling is its elastic part (elastomer). It is supplied in different hardnesses, according to application. Melt of elastomer grants resistance versus wear, UV, strain.... and also versus chemicals.

All Mecvel couplings are supplied standard with 92 Sh-A yellow elastomer.

A request may be provided by elastomers with 98 Sh-A red or green with 64 Sh-D.

Materials:

- Alu-alloy or steel hubs
- Hi-resistance polymer elastomers

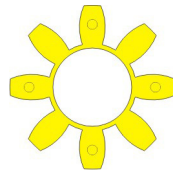

Elastomeric element 92 Sh-A

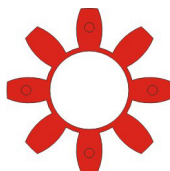

Elastomeric element 98 Sh-A

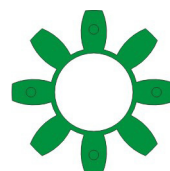

Elastomeric element 94 Sh-D

Elastomeric element: technical characteristics					
Hardness	Material	Color	Allowed temperature ( C)		Uses
			Working	For short period	
92 Sh-A	Polyurethane	Yellow	- 40 +90	-50 +120	low and medium power systems with frequent stop, starts
98 Sh-A	Thermoplastic	Red	- 30 +90	-40 +125	high transmission torque high temperature range
64 Sh-D	Polyurethane	Green	-20 +110	-30 +120	high torsional rigidity internal combustion motors



MecVel reserves the right to change products information and/or features without notice; all data contained in this catalogue are purely indicative and not binding for the company.



Elastomeric element: performance characteristics									
Size	Hardness [SH]	Torque [Nm]		Misalignments			Rigidity		
		Nom	Max	angular	axial	radial	torsional $R_T$ [Nm/rad · 10 <sup>3</sup> ]	axial $R_A$ [N/mm]	radial $R_R$ [N/mm]
G15	92 Sh-A	7.5	15	1°	1	0.14	115	340	330
	98 Sh-A	12.5	25	0° 54'		0.09	170	510	650
	64 Sh-D	16	32	0° 48'		0.06	235	700	855

Elastomeric element: performance characteristics										
Size	Hardness [SH]	Torque [Nm]		Misalignments			Rigidity $R_T$ [Nm/rad · 10 <sup>3</sup> ]			
		Nom	Max	angular $\alpha$ [°]	axial $X$ [mm]	radial $K$ [mm]	25% Torque nom.	50% Torque nom.	75% Torque nom.	100% Torque nom.
G20	92 Sh-A	10	20	1° 18'	1.0	0.4	0.62	0.73	0.93	1.18
	98 Sh-A	17	34				0.92	1.14	1.33	1.49
	64 Sh-D	21	42				1.97	3.33	4.40	5.37
G70	92 Sh-A	35	70	1° 18'	1.0	0.8	2.44	2.71	3.66	4.43
	98 Sh-A	60	120				3.64	4.74	5.47	5.92
	64 Sh-D	75	150				5.50	9.35	12.40	15.10
G190	92 Sh-A	95	190	1° 18'	1.2	1.0	4.10	5.73	6.62	7.65
	98 Sh-A	160	320				6.08	7.82	8.88	10.68
	64 Sh-D	200	400				10.10	17.00	22.55	27.50
G380	92 Sh-A	190	380	1° 18'	1.4	1.0	8.69	10.75	12.55	14.57
	98 Sh-A	325	650				10.95	14.13	18.25	21.90
	64 Sh-D	405	810				25.75	43.50	57.50	70.10
G530	92 Sh-A	265	530	1° 18'	1.6	1.0	11.52	14.66	17.27	21.50
	98 Sh-A	450	900				16.34	21.41	25.17	30.29
	64 Sh-D	560	1120				29.30	49.50	65.45	79.85
G620	92 Sh-A	310	620	1° 18'	1.7	1.4	11.85	18.72	21.34	24.52
	98 Sh-A	525	1050				17.97	24.39	27.68	34.14
	64 Sh-D	655	1310				35.10	59.20	78.30	95.50
G820	92 Sh-A	410	820	1° 18'	1.8	1.4	16.63	26.27	29.94	34.42
	98 Sh-A	685	1370				24.88	33.77	38.33	47.27
	64 Sh-D	825	1650				39.65	66.90	88.55	107.90
G1250	92 Sh-A	625	1250	1° 18'	2.0	1.4	27.14	38.00	40.71	50.67
	98 Sh-A	940	1880				36.00	48.01	55.55	66.47
	64 Sh-D	1175	2350				55.54	93.65	124.00	150.10

**TYPE G - TWO STANDARD HUBS**

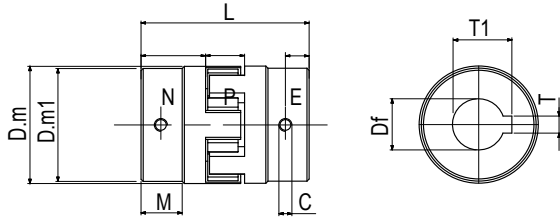

**TYPE GL - TWO LONG-SLEEVE HUBS**  
Steel Only

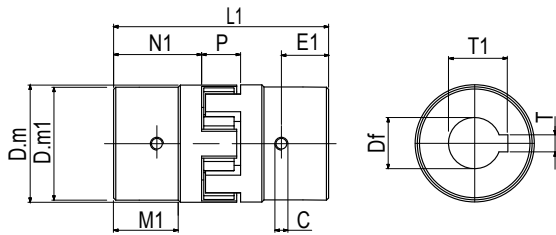

**TYPE GSL - STANDARD + LONG-SLEEVE HUB**  
Steel Only

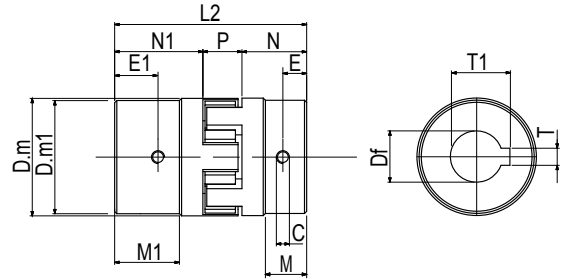

Features for G-series couplings																			
Size	Torque max.	Nominal Torque	Df Max	Df Standard	T	T1	C	Dm	Dm1	E	N	N1	M	M1	L	L1	L2	P	Material
	Cmax [Nm]	C [Nm]																	
G15	15	7.5	16	10	3	11.4	M4	30	30	5	19	18.5	-	-	50	-	-	12	Alu./Steel
				14	4	15.8													
G20	20	10	25	14	4	15.8	M5	40	40	10	25	-	16.5	28.5	66	-	78	16	Alu./Steel
				19	6	21.8													
G70	70	35	35	19	6	21.8	M5	55	53	10	30	60	18.5	38.5	78	-	98	18	Alu./Steel
				24	8	27.3													
G190	190	95	40	24	8	27.3	M8	65	63	15	35	60	24	49	90	140	115	20	Alu./Steel
				28	8	31.3													
				30	8	33.3													
G380	380	190	48	28	8	31.3	M8	80	78	15	45	70	33	58	114	164	139	24	Alu./Steel
				30	8	33.3													
				38	10	41.3													
G530	530	265	55	30	8	33.3	M8	95	93	15	50	75	38	63	126	176	151	26	Steel
				38	10	41.3													
				48	14	51.8													
G620	620	310	62	48	14	51,8	M8	105	103	20	56	80	45	69	140	188	164	28	Steel
				60	18	64,4													
G820	820	410	74	48	14	51,8	M10	120	118	20	65	90	49	74	160	210	185	30	Steel
G1250	1250	625	80	48	14	51,8	M10	135	133	20	75	100	61	86	185	235	210	35	Steel



The torques are refer at couplings with 92 Sh-A yellow elastomer.  
For torques with different elastomers transmissible contact our Technical Department.



## CLAMP-FASTEN COUPLINGS GM

GM-series couplings add an advantage to G-series: they can be installed after installation of screwjacks.  
All Mecvel couplings are supplied with 92 Sh-A yellow elastomer.

Materials:

- Alu-alloy clamps (in two halves)
- Hi-resistance polymer elastomers

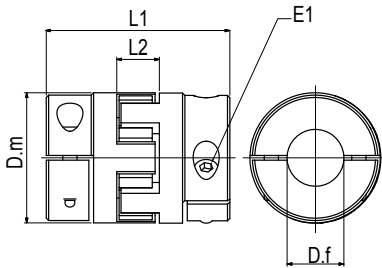

		Features for GM-series couplings				
Size		GM15	GM20	GM70	GM190	GM380
Torque max.	$C_{max}$ [Nm]	15	20	70	190	380
Nominal Torque	$C$ [Nm]	7.5	10	35	95	190
Hub external diameter	$D_m$ [mm]	30	40	55	65	85
Max hole admitted diameter	$D_f$ [mm]	14	20	30	35	45
Fastening bolts	$E1$	M4	M5	M6	M8	M8
Fastening torque	[Nm]	3.1	6.2	10.5	25	25
Total length	$L1$ [mm]	50	66	78	90	114
Distance between hubs	$L2$ [mm]	12	16	18	20	24

Size	Torque transmitted [Nm] according $\varnothing$ finished bore [mm]																					
	6	8	10	11	12	14	15	16	18	19	20	22	24	25	28	30	32	35	38	40	42	45
GM15	5	7	8.5	9.5	10.5	12	13															
GM20			14	15	17	20	21	22	25	27	28											
GM70					24	28	30	32	36	38	40	44	47	49	55	59						
GM190									65	69	73	80	87	91	102	109	116	127				
GM380											73	80	87	91	102	109	116	127	138	142	152	163

### COUPLINGS ORDERING KEY

G15 / 14/14/ A / Y

MODEL \_\_\_\_\_

G15 / G20 / G70 / G190 / G380 / G530 / G620 / G820 / G1250  
 GL15 / GL20 / GL70 / GL190 / GL380 / GL530 / GL620 / GL820 / GL1250  
 GSL15 / GSL20 / GSL70 / GSL190 / GSL380 / GSL 530/ GSL 620 / GSL 820 / GSL 1250

COUPLING HOLES DIAMETER \_\_\_\_\_

es.  $\varnothing 14$  for both couplings= 14/14  
 es.  $\varnothing 14$  for one and 16 for the other = 14/16

MATERIAL \_\_\_\_\_

S Steel                      A Aluminium

TYPE \_\_\_\_\_

Y Yellow                      R Red                      G Green

### CLAMP-FASTEN COUPLINGS ORDERING KEY

GM15 / 14/14/ Y

MODEL \_\_\_\_\_

GM15 / GM20 / GM70 / GM190 / GM380

COUPLING HOLES DIAMETER \_\_\_\_\_

es.  $\varnothing 14$  for both couplings= 14/14  
 es.  $\varnothing 14$  for one and 16 for the other = 14/16

TYPE \_\_\_\_\_

Y Yellow                      R Red                      G Green

## TRANSMISSION SHAFT

Clamped couplings allow transmission shafts to be installed after screwjack installation. Transmission shall be plugged to screwjack shaft, then the two halves of coupling shall be tightened (via their bolts) according to torque shown below.

Features:

- Radial mounting
- 3 mtr. max length
- Low inertia momentum
- Vibration absorption
- Safe tight-on mounting
- No angular backlash

Materials:

- Aluminium alloy clamps
- Melt of elastomer grants resistance versus wear, UV, strain and also versus chemicals
- Aluminium alloy extension tube

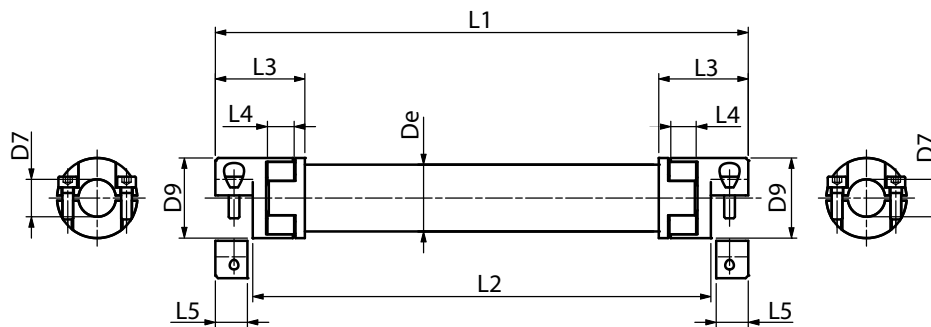
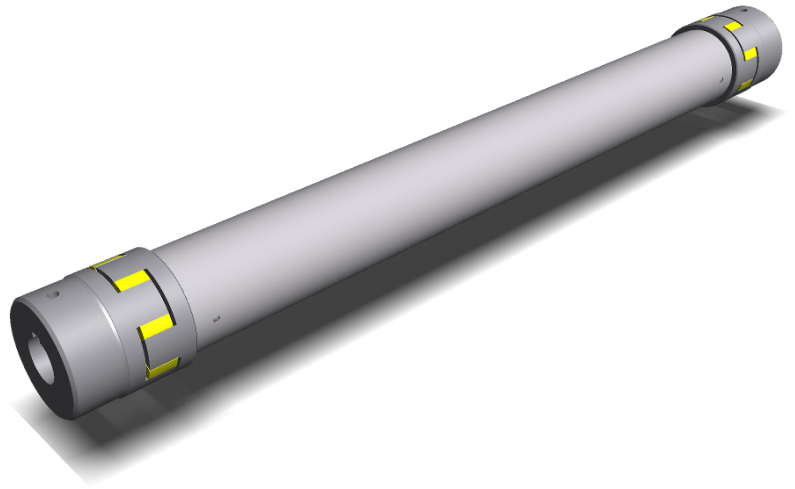

Transmission shaft features						
Size		ATM15	ATM20	ATM70	ATM190	ATM380
Torque max.	$C_{max}$ [Nm]	15	20	70	190	380
Nominal Torque	$C$ [Nm]	7.5	10	35	95	190
Hub external diameter	$D9$ [mm]	30	40	55	65	80
Tube external diameter	$D_e$ [mm]	25	36	50	60	
Hole diameter	$D7$ [mm]	10   14	14   19	19   24	30	
Max admitted diameter		15	20	30	35	45
Fastening bolts M8.8	$E$	M4	M5	M6	M8	M8
TTightening torque	[Nm]	3.1	6.2	10.5	25	25
Total length	$L1$ [mm]	max 3000	max3000	max 3000	max 3000	max 3000
Installation length	$L2$ [mm]	L1-28	L1-38	L1-44	L1-50	L1-68
Hub length	$L3$ [mm]	34.5	49.5	59.5	66	80
Distance between hubs	$L4$ [mm]	12	16	18	20	24
Clamp length	$L5$ [mm]	12	17	20	23	32
Couplings weight	kg	0.1	0.28	0.65	1.1	1.9
Weight for 100 mm	Kg	0.05	0.160	0.145	0.3	



MecVel reserves the right to change products information and/or features without notice; all data contained in this catalogue are purely indicative and not binding for the company.



## TRANSMISSION SHAFT AT

Features:

- 3 mtr. max lenght
- Low inertia momentum
- Vibration absorption
- Keyed-hole mounting
- No angular backlash

Materials:

- Aluminium alloy clamps, this depends on the size
- Melt of elastomer grants resistance versus wear, UV, strain and against chemicals
- Aluminium alloy extension tube

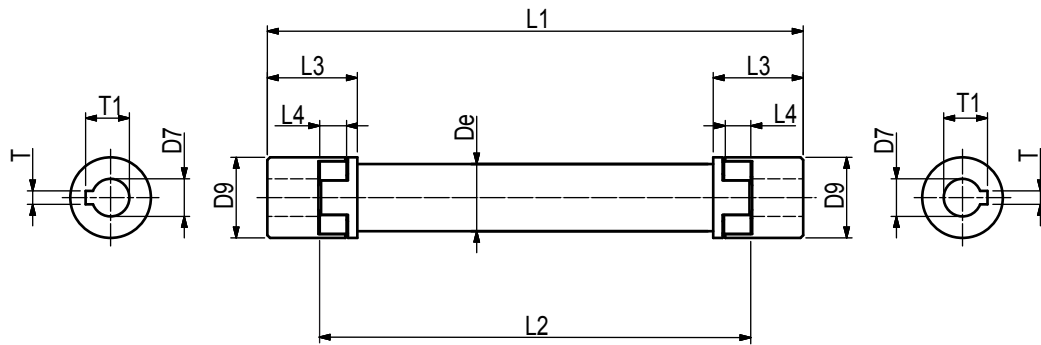

		Features transmission shaft													
Size		AT15		AT20		AT70		AT190		AT380		AT530		AT620	
Torque max.	$C_{max}$ [Nm]	15		20		70		190		380		530		620	
Nominal Torque	$C$ [Nm]	7.5		10		35		95		190		265		310	
Hub external diameter	$D9$ [mm]	30		40		55		65		80		95		105	
Tube external diameter	$D_e$ [mm]	25		36		50		60		70		70		85	
Hole diameter (standard)	$D7$ [mm]	10	14	14	19	19	24	30	38	42	48	30	48	48	60
Max admitted diameter		16		25		35		40		48		55		62	
Keyway	$T$	3	4	4	6	6	8	8	10	12	14	8	14	14	18
	$T1$	11.4	15.8	15.8	21.8	21.8	27.3	33.3	41.3	45.3	51.8	33.3	51.8	51.8	64.4
Total lenght	$L1$ [mm]	max 3000		max3000		max 3000		max 3000		max 3000		max 3000		max 3000	
Installation lenght	$L2$ [mm]	L1-37		L1-50		L1-60		L1-70		L1-90		L1-100		L1-112	
Hub lenght	$L3$ [mm]	34.5		49.5		59.5		66		80		86		95	
Distance between hubs	$L4$ [mm]	12		16		18		20		24		26		28	
Couplings weight	kg	0.1		0.28		0.65		1.1		5,5		8.5		11	
Weight for 100 mm	Kg	0.05		0.160		0.145		0.3		0.35		0.35		0.56	
Hubs material		Aluminium										Steel			

## SIZING LENGHT ON TRANSMISSION SHAFTS FOR SCREWJACKS

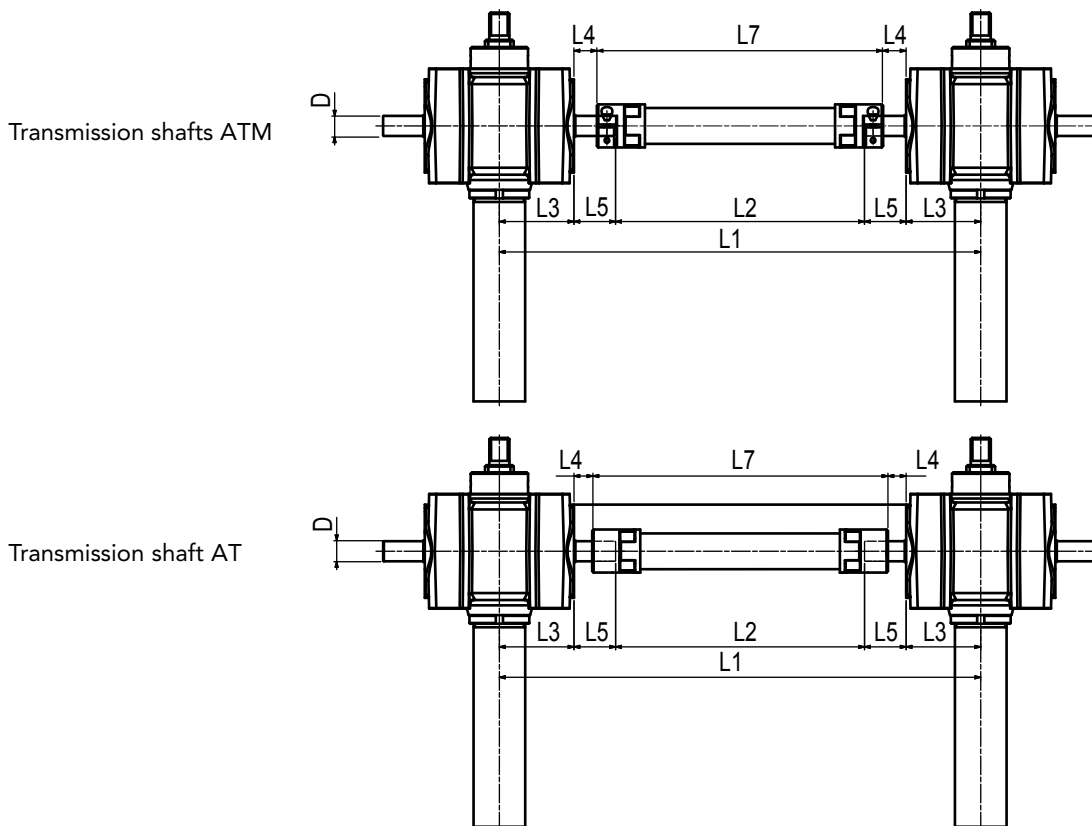

<i>Dimensions for transmission shafts mounting</i>							
Size	Shaft Type	D	L2	L3	L4	L5	L7
05	ATM15	10	L1 - 132	39.5	12.5	26.5	L1 - 104
	AT15	10	L1 - 132	39.5	8.5	26.5	L1 - 96
	ATM20	10	L1 - 132	39.5	7.5	26.5	L1 - 94
	AT20	10	L1 - 132	39.5	1.5	26.5	L1 - 82
10	ATM15	14	L1 - 162	53	14	28	L1 - 134
	AT15	14	L1 - 162	53	17	28	L1 - 140
	ATM20	14	L1 - 162	53	9	28	L1 - 124
	AT20	14	L1 - 162	53	3	28	L1 - 112
25	ATM20	16	L1 - 222	68	24	43	L1 - 184
	AT20	16	L1 - 222	68	18	43	L1 - 172
	ATM70	16	L1 - 222	68	23	43	L1 - 182
	AT70	16	L1 - 222	68	13	43	L1 - 162
50	ATM70	19	L1 - 262	85	26	46	L1 - 222
	AT70	19	L1 - 262	85	16	46	L1 - 202
100	ATM70	24	L1 - 341	104.5	46	66	L1 - 301
	AT70	24	L1 - 341	104.5	36	66	L1 - 281
	ATM190	24	L1 - 341	104.5	43	66	L1 - 295
	AT190	24	L1 - 341	104.5	31	66	L1 - 272
200	ATM190	30	L1 - 372	126	37	60	L1 - 326
	AT190	30	L1 - 341	126	25	60	L1 - 302



## SIZING COUPLINGS AND TRANSMISSION SHAFTS

Torque to be transferred is primary for a correct selection of coupling and transmission →

$$C_{nom} = \frac{9550 \cdot P}{rpm}$$

Following formulas are to be used for sizing →

$$C_{nom} > C_{mot} \cdot F_t$$

Dove:

$C_{nom}$  nominal (theoretical) torque for the coupling [Nm]

$C_{mot}$  nominal motor torque [Nm]

$F_t$  thermal factor

Once choice of coupling according to torque to be transferred is done and double-checked, now flexibility is to be also considered. Each coupling can admit a certain level of mis-alignment, matching it with the ones meant for the application to be fitted. In case all types of mis-alignment happen, total shall not overcome (in percentage) 100%. (see diagram)

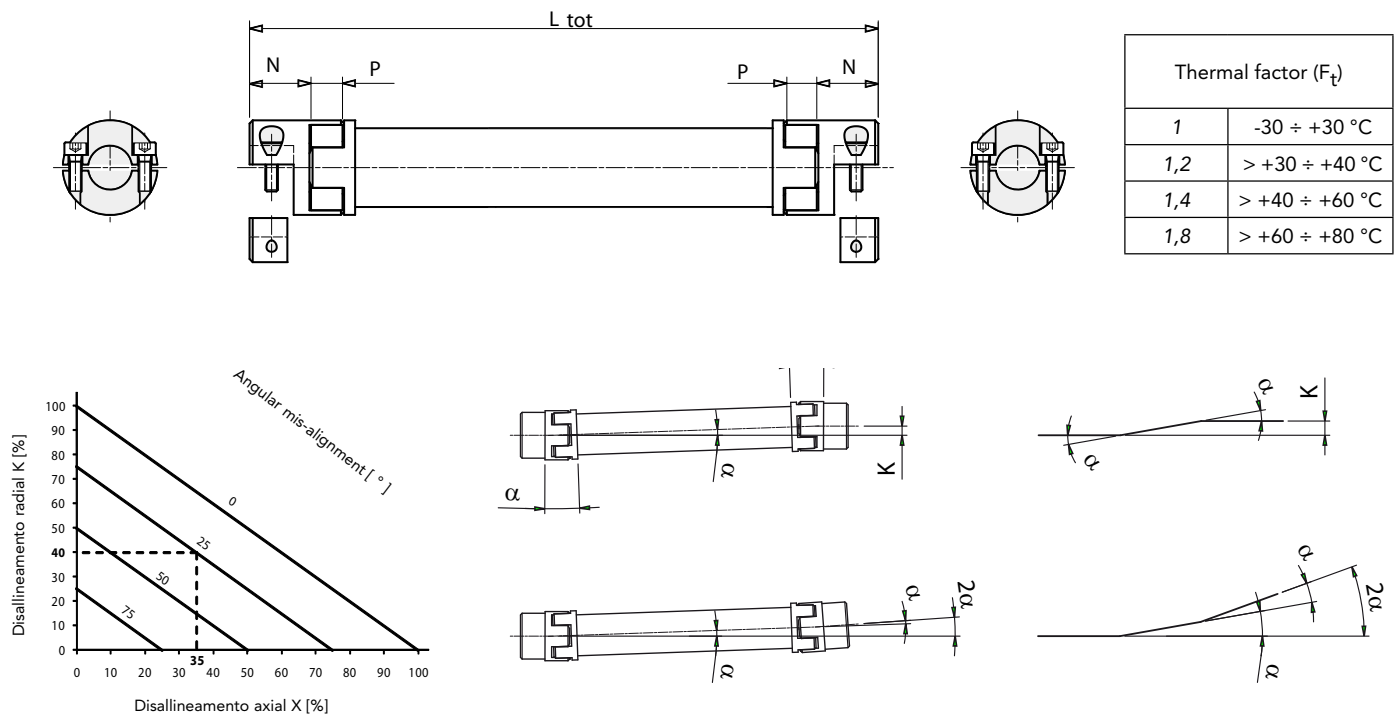

$$K = [ L_{tot} - (2 N) - P ] \cdot Tg \alpha$$

Dove:

$L_{tot}$  total transmission length [mm]

$K$  Radial mis-alignment [mm]

$N$  actual hub length [mm]

$P$  actual spacing of elastomer [mm]

$\alpha$  angular mis-alignment [ ° ]

## TRANSMISSION SHAFTS ORDERING KEY

AT15/0250/14/14

### MODEL

AT15 / AT25 / AT70 / AT190

ATM15 / ATM25 / ATM70 / ATM190

### LENGHT

es. 250 mm = 0250

### COUPLINGS HOLES DIAMETERS

es. Ø14 for both couplings= 14/14

es. Ø14 for one and 16 for the other = 14/16



## BEVELGEARS

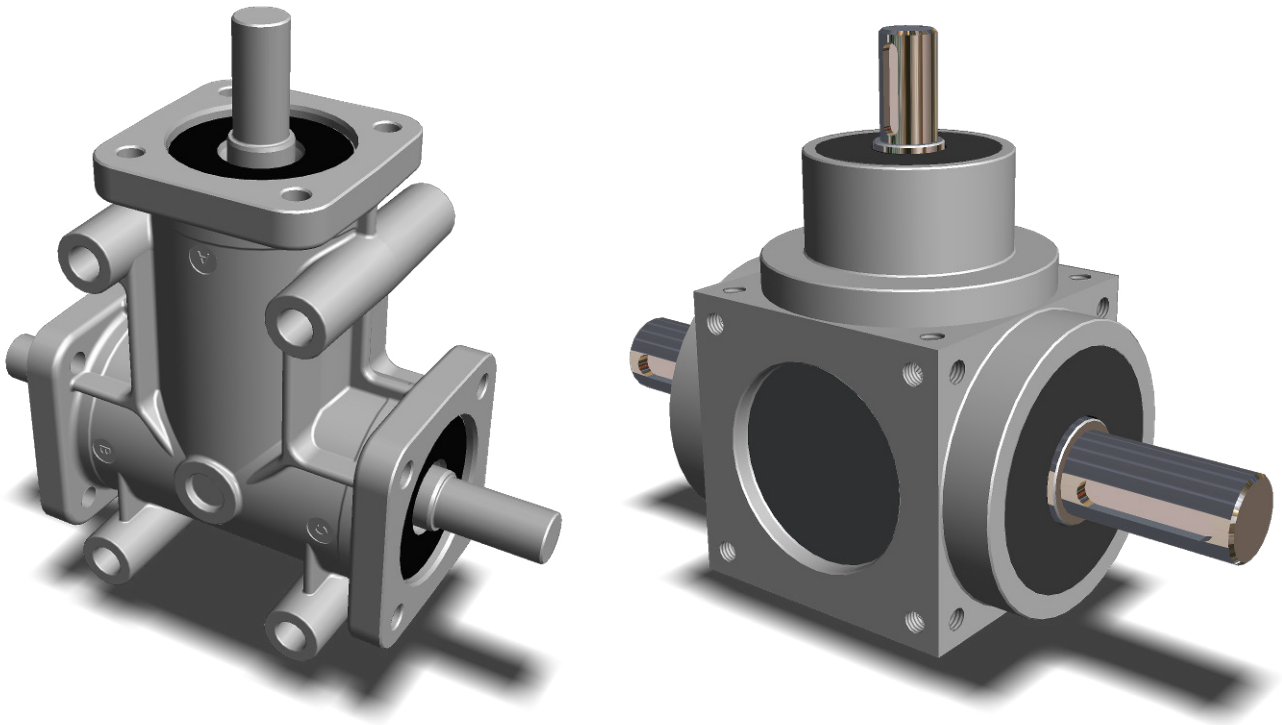

### DESCRIPTION

Bevelgears B and BC are designed for applications where a rotary movement shall be transferred between perpendicular drives. Different sizes are available. They feature 2 or 3 output shafts and gear ratio can be 1:1 or 1:2 or 1:3 for the B version, for the BC version is provided only the 1:1 gear ratio.

### MAIN COMPONENTS FOR ANGULAR DRIVES

An Alu gearbox hosts a bevel gear, with output shafts.

### MATERIALS FOR MAIN COMPONENTS

- Aluminium alloy casing
- Nickel-Chrome bevel gears, with temper+hardening treatment
- Corrosion-proof coating for output shafts
- NBR seals
- Ball bearings for B-series and roller bearings for BC-series

### LUBRICATION

Bevelgears are supplied as lubricated. Size 1 is with grease (and does not need refills), while other sizes are oil-lubricated. For special purposes, dedicated oils and greases are available.

### BEVELGEARS

Following parameters shall be considered for selection:

- Torque to be transferred
- Number of rpms
- Duty service
- Axial and radial loads on shafts
- Temperature



## GEARS

Backlash tolerances can be reduced to a minimum of 5' if specifically requested; ask for details of special prices and delivery conditions on these orders.

## SHAFTS

Keyways can be made at any angle.

## NOMINAL POWER

Nominal power is calculated using this formula:

$$P_n = P_e \times F_s$$

That reads as:

$P_n$  nominal power  
 $P_e$  effective power  
 $F_s$  duty service

## "FR" RADIAL LOADS AND "FA" AXIAL LOADS

Radial loads  $F_r$  admitted on gearbox (see page 65-69) are to be considered as applied on the midst of outputshaft edge. Axial loads  $F_a$  admitted on gearbox (see page 65-69) are to be considered as applied on the midst of outputshaft.

## TEMPERATURE (WHEN ON DUTY)

-20 C +80 C is the boundary for temperature when system is working

## CASCADE OF BEVELGEARS

When using ratios 1:2 or 1:3 as cascade, inputspeeds shall not exceed following:

ratio 1:2 = 750 round/1'

ratio 1:3 = 500 round/1'

BEVELGEARS WITH HOLLOWSHAFTS AND SPECIAL DIMENSIONS ARE AVAILABLE.  
BC SERIES ARE ALSO AVAILABLE FOR DIRECT MOTORCONNECTION.

<i>F<sub>s</sub> duty service specification</i>				
<i>Type of load</i>	<i>ore di funzionamento al giorno</i>			
	<i>3</i>	<i>8</i>	<i>12</i>	<i>24</i>
<i>uniform load</i>	<i>0.7</i>	<i>0.9</i>	<i>1</i>	<i>1.3</i>
<i>load with moderate shocks</i>	<i>0.9</i>	<i>1</i>	<i>1.3</i>	<i>1.8</i>
<i>load with shocks</i>	<i>1.3</i>	<i>1.6</i>	<i>1.8</i>	<i>2.3</i>

 MecVel reserves the right to change products information and/or features without notice; all data contained in this catalogue are purely indicative and not binding for the company.

## B-SERIES BEVELGEARS

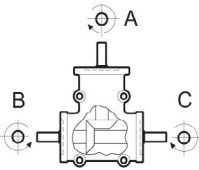
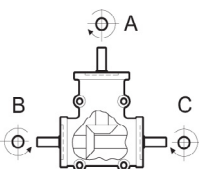
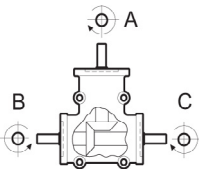
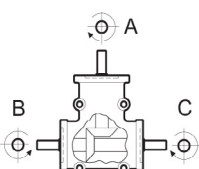
B-series Bevelgears						
MODEL	Shaft diameter	Ratio	Inputshaft	Outputshaft	Mounting position	Weight Kg
B1 	Ø 8	1/1	A	B	1-2	0.6
		1/1	A	B-C	3	
		1/2	A	B	1-2	
		1/2	A	B-C	3	
B2 	Ø 14	1/1	A	B	1-2	2.0
		1/1	A	B-C	3	
		1/2	A	B	1-2	
		1/2	A	B-C	3	
		1/3	A	B	1-2	
		1/3	A	B-C	3	
B3 	Ø 19	1/1	A	B	1-2	4.5
		1/1	A	B-C	3	
		1/2	A	B	1-2	
		1/2	A	B-C	3	
		1/3	A	B	1-2	
		1/3	A	B-C	3	
B4 	Ø 24	1/1	A	B	1-2	4.6
		1/1	A	B-C	3	
		1/2	A	B	1-2	
		1/2	A	B-C	3	
		1/3	A	B	1-2	
		1/3	A <td B-C	3		

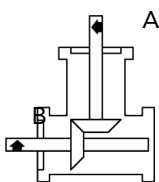
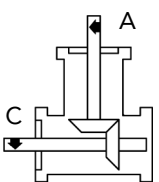
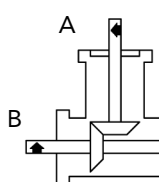
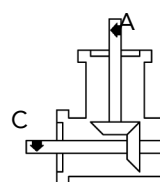
Mounting positions		
POS. 1	POS. 2	POS. 3
		 



Input power table for inputshaft A																	
Output speed		50 rpm		100 rpm		200 rpm		400 rpm		800 rpm		1400 rpm		2000 rpm		3000 rpm	
Output torque		Mt	power	Mt	power	Mt	power	Mt	power	Mt	power	Mt	power	Mt	power	Mt	power
Size	Ratio	Nm	Kw	Nm	Kw	Nm	Kw	Nm	Kw	Nm	Kw	Nm	Kw	Nm	Kw	Nm	Kw
1	1:1	9.1	0.05	7.6	0.08	6.4	0.13	5.4	0.23	4.5	0.38	4.0	0.58	3.6	0.75	3.3	1.03
2		34,5	0.18	29.0	0.30	24.4	0.51	20.5	0.86	17.2	1.44	15.0	2.2	13.7	2.87	12.4	3.89
3		87.3	0.46	73.4	0.77	61.8	1.29	51.9	2.17	43.7	3.66	38.0	5.56	34.7	7.27	31.4	9.86
4																	
1	1:2	8.9	0.05	7.5	0.08	6.3	0.13	5.3	0.22	4.4	0.37	3.9	0.57	3.5	0.74	3.2	1.65
2		33.8	0.18	28.5	0.30	23.9	0.50	20.1	0.84	16.9	1.42	14.7	2.16	13.5	2.84	12.2	3.82
3		82.3	0.43	69.2	0.72	58.2	1.2	48.9	2.05	41.1	3.44	35.8	5.24	32.7	6.85	29.6	9.28
4																	
2	1:3	27.5	0.14	23.1	0.24	19.4	0.41	16.3	0.68	13.7	1.15	12.0	1.75	10.9	2.29	9.9	3.10
3		63.4	0.33	53.3	0.56	44.9	0.94	37.7	1.58	31.7	2.66	27.6	4.04	25.2	5.28	22.8	7.16
4																	

B-series bevelgears, max external loads according to speed																	
Output speed		50 rpm		100 rpm		200 rpm		400 rpm		800 rpm		1400 rpm		2000 rpm		3000 rpm	
Radial / axial load		Fr	Fa	Fr	Fa	Fr	Fa	Fr	Fa	Fr	Fa	Fr	Fa	Fr	Fa	Fr	Fa
Size	Ratio	N	N	N	N	N	N	N	N	N	N	N	N	N	N	N	N
1	1:1	195	158	164	133	138	112	116	94	98	79	85	69	78	63	70	57
2		516	418	434	531	365	295	307	248	258	209	224	182	205	166	185	150
3		953	639	802	537	674	452	567	380	477	319	414	278	379	254	342	229
4																	
1	1:2	182	110	153	93	129	78	108	66	91	55	79	48	73	44	66	40
2		445	316	374	266	315	224	265	188	223	158	194	137	177	126	160	114
3		803	483	675	406	568	341	478	287	402	241	349	210	319	192	289	173
4																	
2	1:3	357	199	301	167	253	141	213	118	179	99	155	86	142	79	128	71
3		619	346	521	291	438	245	368	206	310	173	269	151	246	138	222	124
4																	

### DIMENSIONS B1

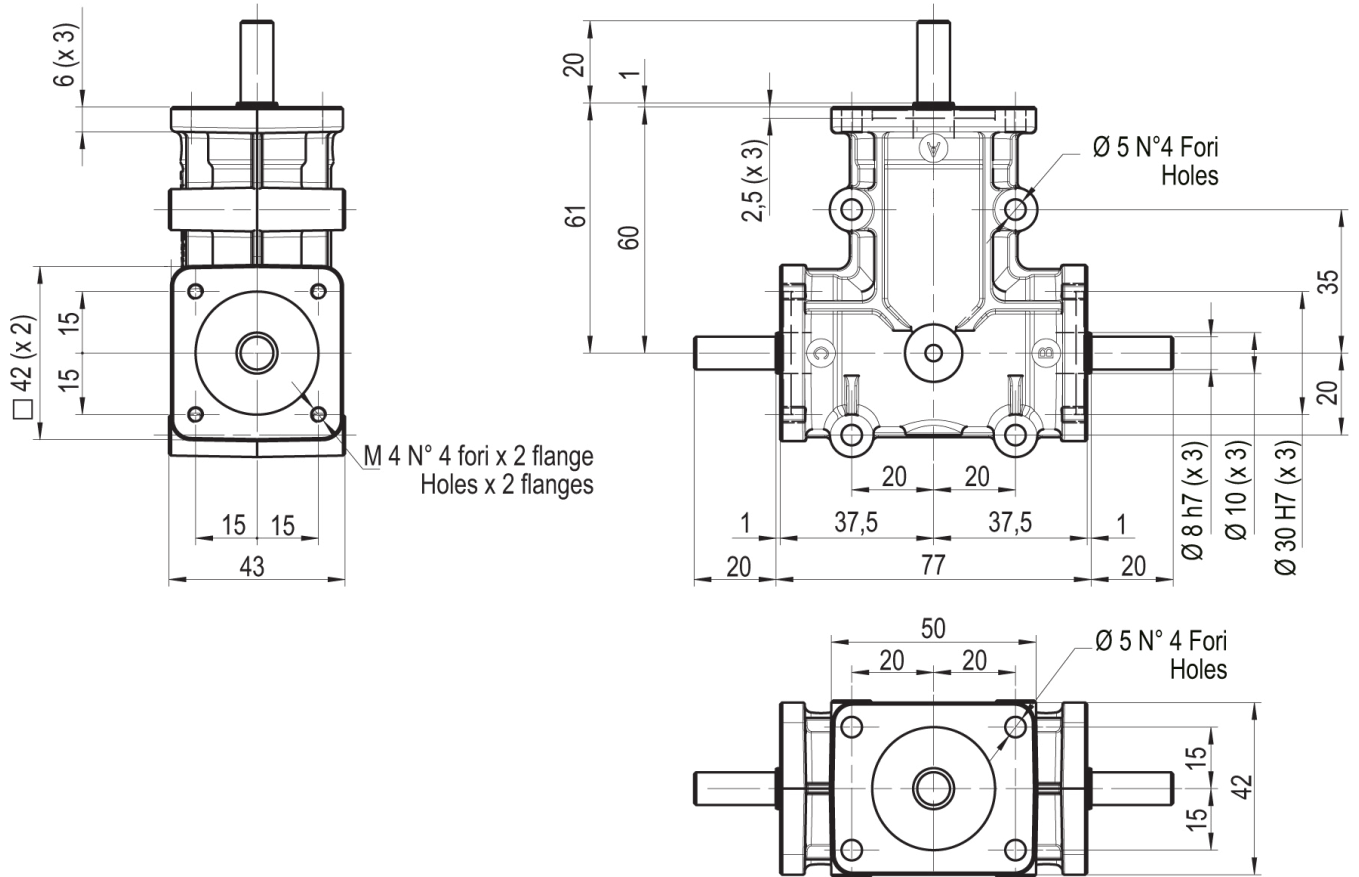

### DIMENSIONS B2

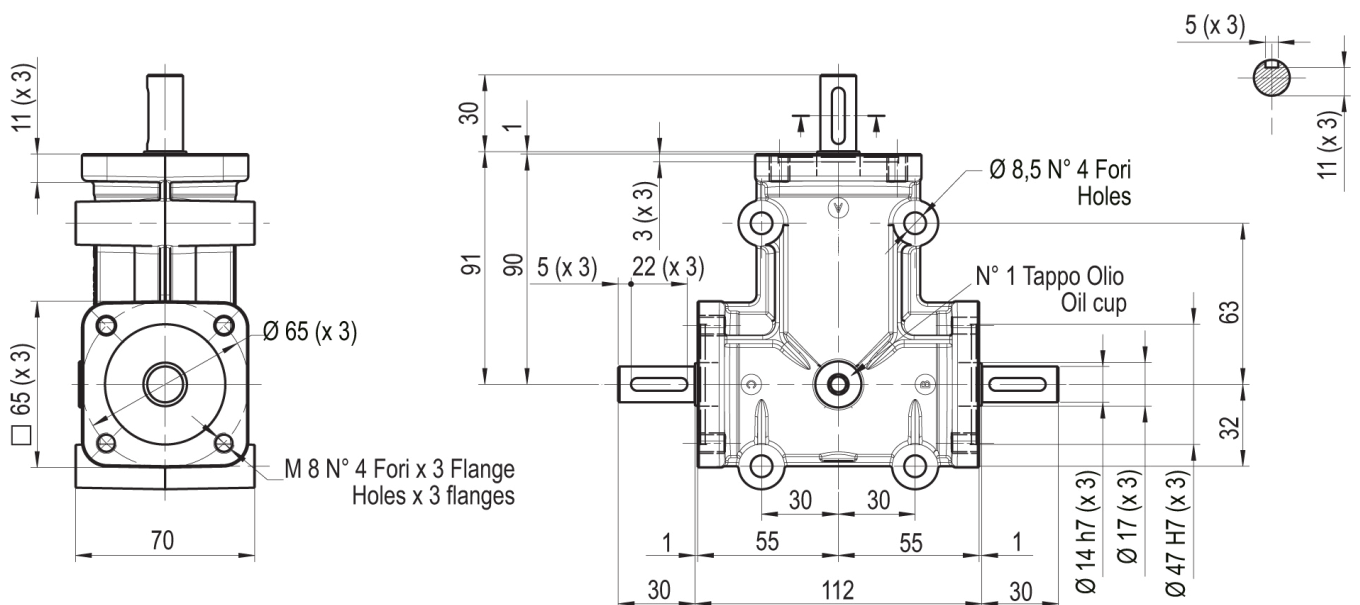



## DIMENSIONS B3

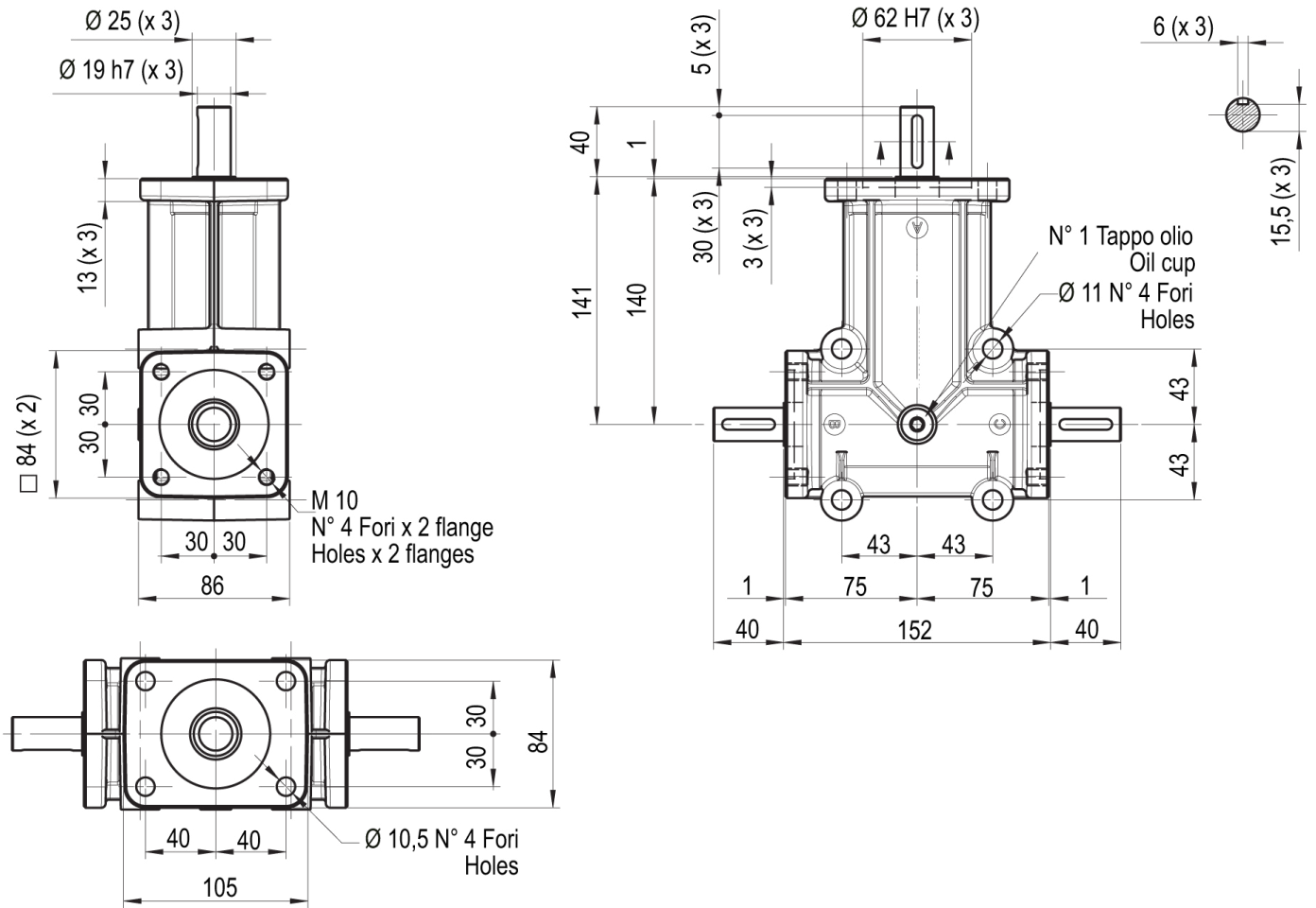

## DIMENSIONS B4

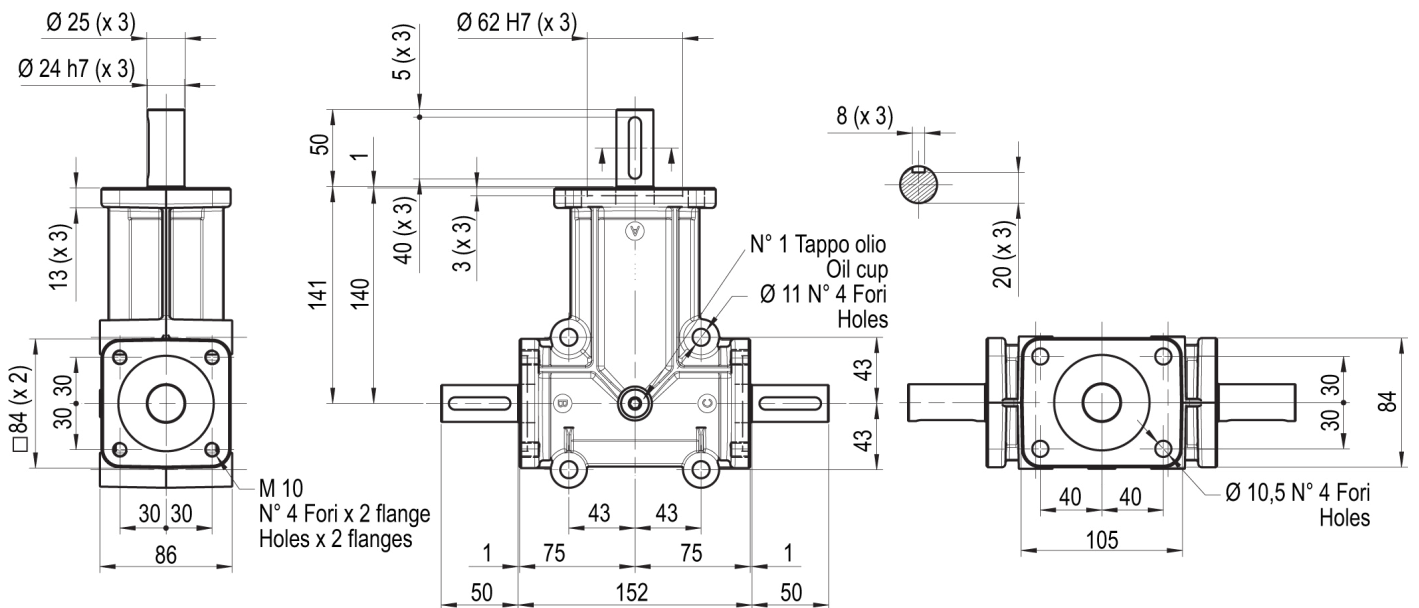

## BC-SERIES BEVELGEARS

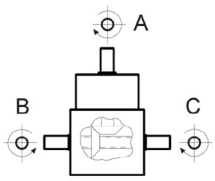
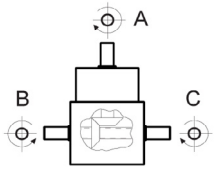
BC-series Bevelgears							
MODEL	Inputshaft diameter	Outputshaft diameter	Ratio	Inputshaftf	Outputshaftf	Mounting position	Weight Kg
 BC1	Ø 11	Ø 18	1/1	A	B	1-2	1.1
			1/1	A	B-C	3	
 BC2	Ø 16	Ø 24	1/1	A	B	1-2	2.2
			1/1	A	B-C	3	

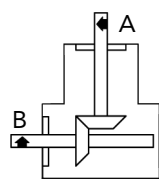
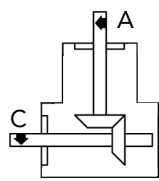
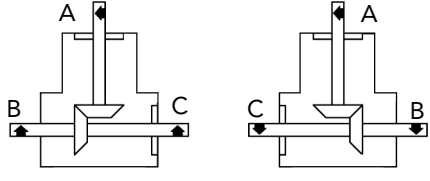
Mounting positions		
POS. 1	POS. 2	POS. 3
		

BC-series Bevelgears, input power table for inputshaft A																	
Output speed		50 rpm		100 rpm		200 rpm		400 rpm		800 rpm		1400 rpm		2000 rpm		3000 rpm	
Output torque		Mt	power	Mt	power	Mt	power	Mt	power	Mt	power	Mt	power	Mt	power	Mt	power
Size	Ratio	Nm	Kw	Nm	Kw	Nm	Kw	Nm	Kw	Nm	Kw	Nm	Kw	Nm	Kw	Nm	Kw
1	1:1	27.5	0.14	23.1	0.24	19.4	0.41	16.3	0.68	13.7	1.15	12.0	1.75	10.9	2.29	9.9	3.10
2		151.5	0.79	126.3	1.32	106.2	2.22	89.3	3.74	75.1	6.29	65.3	9.57	59.7	12.5	53.9	16.94

BC-series Bevelgears, max external loads according to speed																	
Output speed		50 rpm		100 rpm		200 rpm		400 rpm		800 rpm		1400 rpm		2000 rpm		3000 rpm	
Radial / axial load		Fr	Fa	Fr	Fa	Fr	Fa	Fr	Fa	Fr	Fa	Fr	Fa	Fr	Fa	Fr	Fa
Size	Ratio	N	N	N	N	N	N	N	N	N	N	N	N	N	N	N	N
1	1:1	617	412	519	346	436	291	367	245	309	206	268	179	245	164	222	148
2		611	396	514	333	432	280	363	235	306	198	266	172	243	157	220	142





## GENERAL SALES CONDITIONS

### ART. 1 APPLICABLE LAW AND CONCLUSION OF THE CONTRACT

1.1 Any matter regarding the relationship between MECVEL and the Buyer that is not explicitly or implicitly resolved by the dispositions of the present General Sales Conditions or by possible special conditions agreed upon by the parties and settled in the sale contract (that in case of contrast will be considered prevailing) will be governed by the Italian law.

1.2 Any modification to the present General Sales Conditions must be made in writing.

1.3 The sale contract (hereinafter called "contract") has to be considered as concluded when, on reception of an order, the Producer has sent an acceptance in writing within the term eventually fixed by the Buyer.

### ART. 2 CHARACTERISTICS OF THE PRODUCTS AND DESCRIPTIVE DOCUMENTS

2.1 Any information relating to working characteristics of the products, weights, dimensions, abilities, prices, outputs, and other data contained in catalogues, prospectus, circulars, advertising, illustrations or price-lists of the Producer, have character of approximate indications. These information shall be binding only to the extent they are expressly referred to in the contract.

2.2 Any design or technical document enabling the manufacture of the supplied products or their parts, that the Producer has delivered to the Buyer before or after the stipulation of the contract, remains the Producer's property, and the Buyer cannot use, copy, reproduce, transmit or communicate it to third parties without the consent of the Producer.

2.3 The title of any intellectual or industrial right related to the products is and remains of the Producer.

### ART. 3 PRICE

3.1 Unless otherwise agreed the price does not include value added tax, packing, custom costs, transport and accessory expenses, and it is subject to change according to the Producer.

### ART. 4 TESTING

4.1 Whether technical specifications for the tests are not specified in the contract, the tests will be carried out according to the procedures generally followed by the Producer.

4.2 If the Buyer claims for it at the moment of the order, the Producer has to communicate to him when the tests will take place, in order to allow his representatives to be present.

4.3 Unless otherwise agreed the Producer will be charged of all the expenses of the tests carried out in his establishments, in exception of those for the personnel of the Buyer.

### ART. 5 PAYMENT CONDITIONS AND RETENTION OF TITLE

5.1 Payments must be made with the means and to the expiration or expirations arranged by the parties. The obligation of payment is considered fulfilled when the due amount is received from the bank of the Producer in available funds.

5.2 If the delivery occurs before the complete payment, the Products delivered remain the Producer's property until complete payment is received by the Producer.

### ART. 6 INTERESTS ON DELAYED PAYMENT

6.1 In case of delay in any payment by the Buyer, the Producer can actually suspend the fulfilment of his own obligations until complete payment is effected.

6.2 In addition to what is expressed in the preceding point, the Producer will have the right to interests on delayed payment on the amount that is not paid to the agreed date, beginning from the moment in which the payment is due up to the moment in which the payment is made, previous written notice to the Buyer. The parties arrange to fix the rate of the interests on delayed payment to the.....%.

6.3 Whether the delay of the Buyer in making any payment depends on a circumstance listed under article 10, the Producer is not entitled to any interest on delayed payment.

6.4 Whether the delay of the Buyer exceeds 60 days from the agreed date, the Producer has the right to withdraw from the contract, and consequently to get from the Buyer the restitution of the products and the compensation for damages, previous written notice to the Buyer and without having to require a favourable sentence of any Court.

### ART. 7 TIME OF DELIVERY

7.1 Except as otherwise agreed, the supply of goods will be Ex Works the Producer's establishment. The transfer of risks is determined in conformity to the Incoterms of the International Chamber of Commerce, in force at the moment of the contract conclusion.

7.2 Shall the delivery be delayed for any of the circumstances listed under article 10, or for any action or omission of the Buyer, a reasonable extension of the term of such delivery will be granted, considering all the circumstances of the delay.

7.3 Whether the Buyer does not withdraw the products to the agreed time, however he shall be engaged to make all the payments relating to the delivery as if the material had been delivered. The Producer shall care for the storage of the material at the Buyer's expenses and risks. On application of the Buyer the Producer has to assure the material at expenses of the Buyer.

7.4 Except if the Buyer does not withdraw the material because of one of the circumstances specified under article 10, the Producer can require the Buyer to withdraw the material within a reasonable term. Shall the Buyer, for any reason, not comply in the aforesaid term, the Producer shall have the right to withdraw from the contract, in regard to the part of the supply undelivered because of the abovementioned breach of the Buyer, and consequently to get from the Buyer the compensation for those damages suffered because of his breach, previous written notice to the Buyer and without having to require the favourable sentence of any Court.

7.5 Possible penalties for delivery delays due to the Producer must be specified in writing at the conclusion of the sale contract, and they shall exclude any other remedy for his delayed delivery or non-delivery.

### ART. 8 WARRANTY

8.1 Within the limits of the following dispositions, the Producer undertakes to remedy any imperfection that is consequence of any project, materials, or processing defect. Such obligation is limited to defects occurring during the period (hereinafter called "warranty period") of 12 months from the date of delivery to the buyer.



8.2 In order to claim the rights settled in the present article, the Buyer has to notify the Producer of all the manifested defects in writing, and he has to give him any possibility to ascertain and remedy them.

8.3 Upon reception of such notification during the warranty period, the Producer has to remedy the above mentioned defects at his own expenses. Except when the nature of the defects makes it convenient to carry out the reparation on the place, the Buyer shall forward the defective parts to the Producer, so that the latter can repair or replace them. The obligations of the Producer are considered duly carried out with the delivery to the Buyer of the repaired or replaced parts.

8.4 Except as otherwise agreed, the Buyer undertakes to bear all the costs and risks of transport of the defective parts, and the Producer those of the repaired or replaced ones, between the place where the material is located and the seat of the Producer and vice versa.

8.5 The defective products which the Producer has replaced according to the present article will be returned to the Producer within and not later than 15 days, from the date of reception of the goods sent for replacement, by the Buyer or by one of his customers on his behalf.

8.6 The liability of the Producer is limited to those defects manifesting under conditions of employment as provided in the contract and during a correct use. The guarantee does not cover defects due to causes arising after the transfer of the risks as described under clause 7.1, neither it concerns the normal deterioration.

8.7 Specially, the Buyer loses the right to the guarantee in the following cases: failure to comply with the instructions of use, installation and maintenance of the contractual products and the original spare parts, any modifications made to the products and their original spare parts without prior written consent of the Producer; any repairs made to the contractual products by persons not belonging to the Producer's network and using non-original spare parts.

#### **ART. 9 CIVIL LIABILITY OF THE PRODUCER**

9.1 Shall the Buyer or his customers modify the products or use them for purposes other than those indicated in the catalogue without having obtained prior written consent to do so from the Producer, the Producer shall not be held liable for any loss or damage caused to people or property.

9.2 Pursuant to and for the purposes of Presidential Decree no. 224/88 the Producer shall be liable for any damages caused to third parties deriving from the use of the contractual products only in the event that the injured party is able to provide unassailable proof of the existence of the damage claimed, and of the causal link between any defects and the damage.

9.3 The Producer shall not be liable in the following cases: if the defect that has caused the damage did not exist at the moment the Producer delivered the contractual products to the Buyer; if the injured party, while aware of the defect and the danger to which it might give rise, deliberately exposed itself to it; if the damage is caused by a failure to comply with the instructions set out in the manual of use and maintenance of the contractual products, or when it is caused by the use of non-original spare parts mounted on the contractual products.

9.4 The Buyer shall promptly notify the Producer of any accident or potential safety issue relating to use of the contractual products.

#### **ART. 10 FORCE MAJEURE**

10.1 Neither party shall be held in any way liable for any non-fulfilment of one of its obligations if, after the conclusion of the contract, there arise unexpectedly causes that prevent the fulfilment (such as strikes,

fires, mobilisations, requisitions, embargo, monetary restrictions, riots, deficiency of means of transport, general lacks of raw materials and restrictions to the use of energy), to the extent in which it provides the proof (a) that such non-fulfilment was caused by unforeseeable events beyond its control, and (b) that at the moment of conclusion of the contract it could not reasonably foresee such event and its effects on its attitude to perform its contractual obligations, and (c) that it could not reasonably avoid or overcome such event or overcome its effects.

10.2 The party claiming for liability exemption shall notify the counterpart, as soon as possible and immediately after having discovered the impediment and its effects on its attitude to perform its obligations, of the existence of such impediment, as well as the effects of the same on its attitude to face its own obligations. Similar communication must be given as soon as the cause of liability exemption fails. Failure by the breaching party in giving such communication has the effect to make this party responsible for those damages that otherwise could have been avoided.

10.3 Whether the causes of liability exemption last for more than six months, each party shall have the right to terminate the contract. The parties will arrange the repartition of the expenses born up to that moment for the execution of the contract.

#### **ART. 11 JURISDICTION**

11.1 Any matter arising from the present General Sales Conditions and from the single sale contracts governed by them, shall be of exclusive competence of the Court of Bologna. However, as an exception to the above mentioned principle, the Producer is in any case entitled to bring his action before the competent court of the place where the Buyer has his registered seat.



**MecVel reserves the right to change products information and/or features without notice; all data contained in this catalogue are purely indicative and not binding for the company.**



This page is intentionally left blank.