

- AC motor, flange B14
- Planetary gearbox
- Acme lead screw or ballscrew (VRS)
- Chrome plated steel push rod
- Grease Lubricated
- IP55, ttested according to rule CEI EN 60529
NB: Only for brake motors Standard IP54, IP65 on request
- Working temperature range -10°C +60°C
- Intermittent duty S3 30% (5 min) a 30°C - for any other request contact MecVel technical dept.
- Integrated Limit switches for standard
- Potentiometer and encoder on request
- At-Ex II 3 D T4 version (A.C.motor) on request

EC1 (Vac)				
Fmax (N)	Speed (mm/s)	Version	Motor size	Motor power (KW)
500 *	193	M01	IEC63	0.37 2 poles
1250 *	97	M02	IEC71	0.37 4 poles
2000 *	60	M03	IEC71	0.37 6 poles
5000	24	M04	IEC71	0.55 4 poles
5000	15	M05	IEC71	0.25 6 poles
5000	6	M06	IEC63	0.13 4 poles
EC2 (Vac)				
Fmax (N)	Speed (mm/s)	Version	Motor size	Motor power (KW)
1000 *	193	M01	IEC80	0.75 2 poles
2500 *	97	M02	IEC80	0.75 4 poles
2500 *	60	M03	IEC80	0.55 6 poles
10000	24	M04	IEC80	1.1 4 poles
10000	15	M05	IEC80	0.55 6 poles
10000	6	M06	IEC71	0.25 4 poles
EC3 (Vac)				
Fmax (N)	Speed (mm/s)	Version	Motor size	Motor power (KW)
2500 *	193	M01	IEC90	2.2 2 poles
5000 *	97	M02	IEC90	1.8 4 poles
5000 *	60	M03	IEC90	1.1 6 poles
15000	24	M04	IEC90	1.8 4 poles
15000	15	M05	IEC90	1.1 6 poles
15000	6	M06	IEC71	0.37 4 poles
EC4 (Vac)				
Fmax (N)	Speed (mm/s)	Version	Motor size	Motor power (KW)
15000 *	56	M01	IEC112	2.2 6 poles
25000 *	42	M02	IEC100	4 4 poles
30000	25	M03	IEC112	3 6 poles
30000	10	M04	IEC90	1.5 4 poles
EC5 (Vac)				
Fmax (N)	Speed (mm/s)	Version	Motor size	Motor power (KW)
50000	11	M01	IEC100	3 4 poles
50000	7	M02	IEC100	2.2 6 poles

EC1 VRS (ballscrew) (Vac)				
Fmax (N)	Speed (mm/s)	Version	Motor size	Motor power (KW)
500 *	230	M01	IEC63	0.18 2 poles
1250 *	115	M02	IEC63	0.18 4 poles
2000 *	75	M03	IEC71	0.18 6 poles
5000	30	M04	IEC63	0.18 4 poles
5000	19	M05	IEC71	0.18 6 poles
5000	7	M06	IEC63	0.13 4 poles
EC2 VRS (ballscrew) (Vac)				
Fmax (N)	Speed (mm/s)	Version	Motor size	Motor power (KW)
1250 *	230	M01	IEC71	0.37 4 poles
2500 *	150	M02	IEC80	0.55 6 poles
5000 *	60	M03	IEC71	0.37 4 poles
10000 *	35	M04	IEC80	0.55 6 poles
10000	15	M05	IEC63	0.18 4 poles
EC3 VRS (ballscrew) (Vac)				
Fmax (N)	Speed (mm/s)	Version	Motor size	Motor power (KW)
3000 *	230	M01	IEC80	0.75 4 poles
3000 *	150	M02	IEC80	0.55 6 poles
10000 *	60	M03	IEC80	0.75 4 poles
15000 *	35	M04	IEC80	0.75 6 poles
15000	15	M05	IEC71	0.37 4 poles
EC4 VRS (ballscrew) (Vac)				
Fmax (N)	Speed (mm/s)	Version	Motor size	Motor power (KW)
25000 *	60	M01	IEC90	1.8 4 poles
30000 *	35	M02	IEC100	1.5 6 poles
30000	15	M03	IEC90	1.1 4 poles
EC5 VRS (ballscrew) (Vac)				
Fmax (N)	Speed (mm/s)	Version	Motor size	Motor power (KW)
50000	15	M01	IEC90	1.1 4 poles
50000	10	M02	IEC90	0.75 6 poles

* When speed is more than 30 mm/s and/or strokes longer than 350mm, check STROKE SETUP section.

With single-phase motors type M (see in paragraph ACCESSORIES) performances are 20% lower than the three-phase motor.

→ The brakemotor is strongly recommended

BEFORE OPERATING ACTUATOR MAKE SURE YOU READ AND UNDERSTOOD BASIC OPERATIONAL INSTRUCTIONS SHOWN ON USERMANUALS, AVAILABLE FROM WEBSITE. THIS DOCUMENT DISPLAYS MOST TYPICAL STANDARD FEATURES AND SETUPS: CONTACT OUR OFFICES FOR MORE. ACTUATOR SHALL NOT COME TO MECHANICAL STROKE-END, TO AVOID FAILURES. CONSIDER MECVEL'S LIMITSWITCHES (MODEL EC or EC-F) OR PUT THEM ON MACHINE/FRAME.

MecVel reserves the right to change products information and/or features without notice; all data contained in this catalogue are purely indicative and not binding for the company.

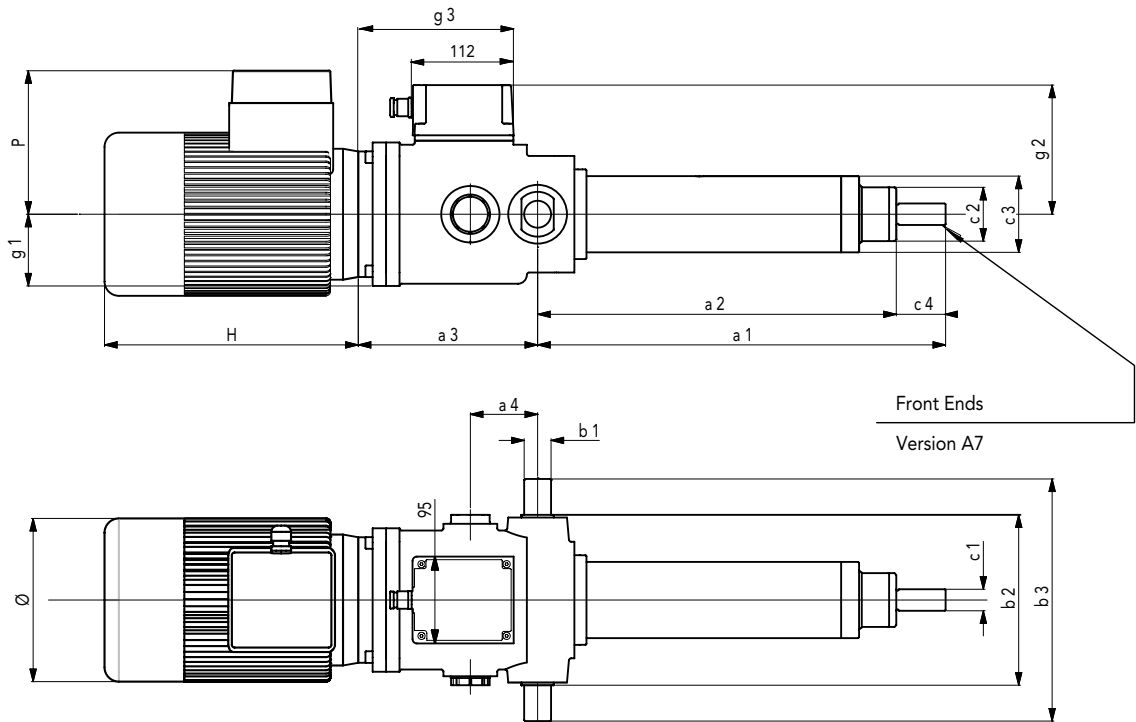

SIZE	DIMENSIONS TABLE													
	1)	1)	2)		(Øh7)								2)	
	a1	a2	a3	a4	b1	b2	b3	c1	c2	c3	c4	g1	g2	g3
1	145	111	*	61	Ø14	105	145	M10	Ø30	Ø50	34	50	103	*
2	167	123	*	66	Ø20	140	200	M12	Ø50	Ø70	44	65	118	*
3	255	200	*	75	Ø30	190	270	M18	Ø60	Ø85	55	80	138	*

SIZE	BALLSCREW DIMENSIONS TABLE													
	1)	1)	2)		(Øh7)								2)	
	a1	a2	a3	a4	b1	b2	b3	c1	c2	c3	c4	g1	g2	g3
1	169	135	*	61	Ø14	105	145	M10	Ø30	Ø50	30	50	103	*
2	233	189	*	66	Ø20	140	200	M12	Ø50	Ø70	35	65	118	*
3	317	262	*	75	Ø30	190	270	M18	Ø60	Ø85	45	80	138	*

- 1) Dimensions are valid for stroke = 0, for the exact overall dimension add the wanted stroke in mm.
- 2) Dimensions change according to actuator model. (see charts sideways)

AC MOTORS DIMENSIONS				
SIZE	VERSIONE / TYPE	H	Ø	P
63	Standard	185	123	110
	Brake motors	234		
71	Standard	215	140	121
	Brake motors	267		
80	Standard	238	159	138
	Brake motors	296		
90	Standard	255	176	149
	Brake motors	319		

EC1	Version					
	M01	M02	M03	M04	M05	M06
	a3	147	157	157	157	157
g3	131	141	141	141	141	156

EC1-VRS	Version					
	M01	M02	M03	M04	M05	M06
	a3	147	147	157	147	157
g3	131	131	141	131	141	156

EC2	Version					
	M01	M02	M03	M04	M05	M06
	a3	182	182	182	182	182
g3	158	158	158	158	158	177

EC2-VRS	Version				
	M01	M02	M03	M04	M05
	a3	169	182	169	182
g3	145	158	145	158	177

EC3	Version					
	M01	M02	M03	M04	M05	M06
	a3	200	200	200	200	200
g3	173	173	173	173	173	199

EC3-VRS	Version				
	M01	M02	M03	M04	M05
	a3	188	188	188	188
g3	161	161	161	161	199

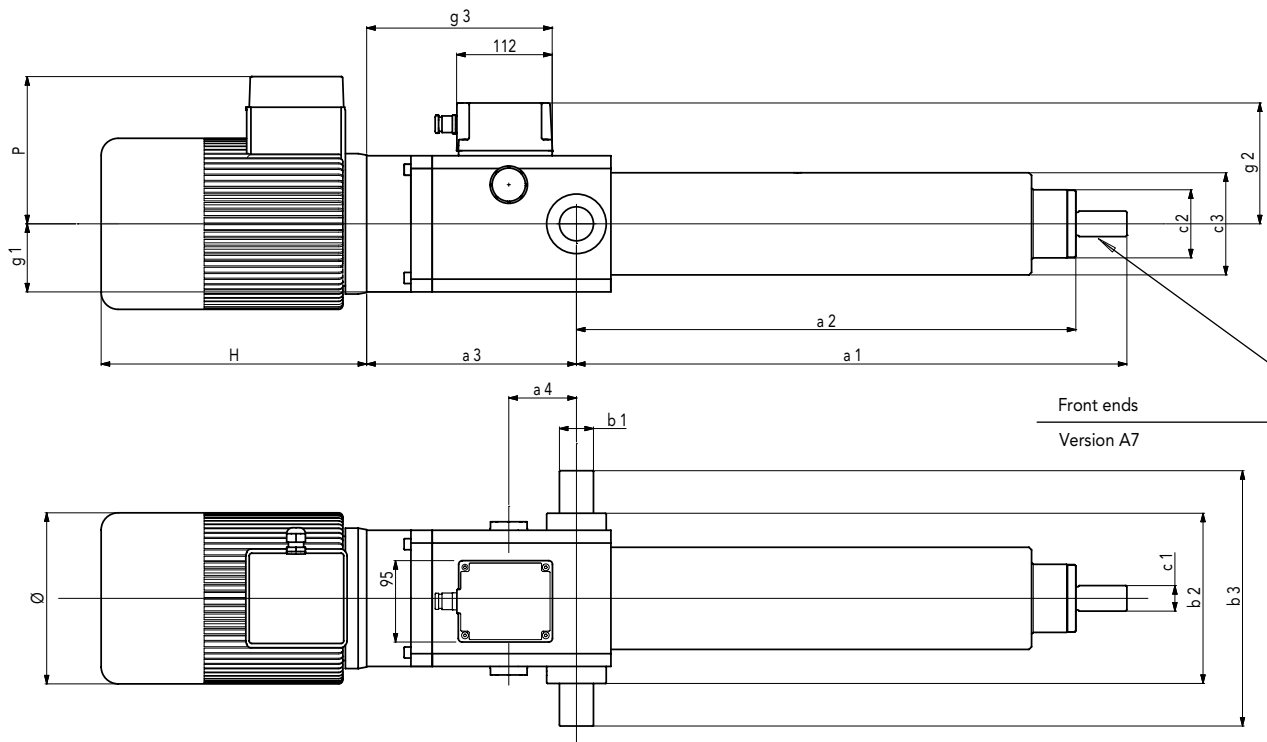

SIZE	DIMENSIONS TABLE													
	1) a1	1) a2	2) a3	a4	Øh7 b1	b2	b3	c1	c2	c3	c4	g1	g2	2) g3
4	272	212	*	79.5	40	200	300	M30x2	80	120	60	80	136	*
5	272	212	*	79.5	40	200	300	M30x2	80	120	60	80	136	*

SIZE	BALLSCREW DIMENSIONS TABLE													
	1) a1	1) a2	2) a3	a4	Øh7 b1	b2	b3	c1	c2	c3	c4	g1	g2	2) g3
4	318	259	*	79.5	40	200	300	M30x2	80	120	60	80	136	*
5	318	259	*	79.5	40	200	300	M30x2	80	120	60	80	136	*

1) Dimensions are valid for stroke = 0, for the exact overall dimension add the wanted stroke in mm.

2) Dimensions change according to actuator model. (see charts sideways)

AC MOTORS DIMENSIONS				
SIZE	TYPE	H	Ø	P
90	Standard	255	176	149
	Brake motors	319		
100	Standard	309	195	173
	Brake motors	374		
112	Standard	328	219	192
	Brake motors	407		

EC4	Version			
	M01	M02	M03	M04
	a3	246.5	246.5	246.5
g3	218	218	218	210

EC4-VRS	Version		
	M01	M02	M03
	a3	200.5	246.5
g3	172	218	210

EC5	Version	
	M01	M02
	a3	284.5
g3	256	256

EC5-VRS	Version	
	M01	M02
	a3	238.5
g3	210	210

A3 = YOKE WITH CLIP DIN 71752 / UNI 1676

SIZE	DIMENSIONS TABLE									
	a1	a1 VRS (BALLSCREW)	a2	a3	a4	a5	a6	a8	a9	a10
1	172	196	14	Ø12	M12	12	61	24	24	24
2	220	286	25	Ø20	M20x1,5	20	97	40	40	40
3	317	379	35	Ø25	M24x2	25	117	50	50	50
4 / 5	345	392	38	Ø30	M27x2	30	131	54	55	55

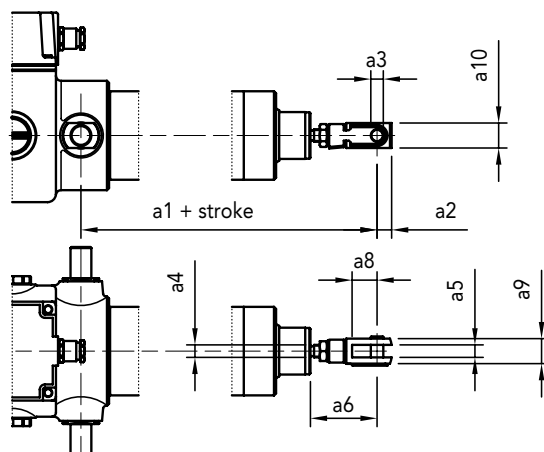

A4 = ROD END DIN 648 serie K / UNI 6126

SIZE	DIMENSIONS TABLE								
	b1	b1 VRS (BALLSCREW)	b2	b3 (ØH7)	b4	b5	b6	b7	b9
1	174	198	16	Ø12	M12	12	16	63	32
2	217	283	25	Ø20	M20x1,5	18	25	94	50
3	313	375	30	Ø25	M24x2	22	31	113	60
4 / 5	345	392	35	Ø30	M27x2	25	37	131	70

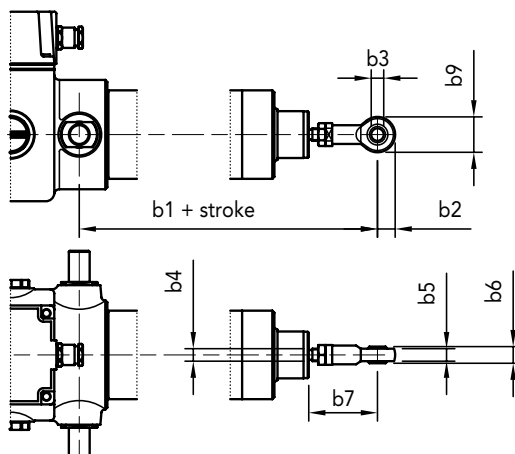

STROKE SETUP

Useful tips for handling stroke and avoid run-on-block collision.

- When stroke is more than 350 mm, add 50 mm extra-stroke as guidance, and put corresponding value in ordering-key.
- **WARNING SPEED-TIMING ALONG STROKELENGTH:** ramps are extremely important when speed is >30 mm/s!!! Inverter or PWM drive recommended!
- The more speed raises the more extra stroke has to raise too.

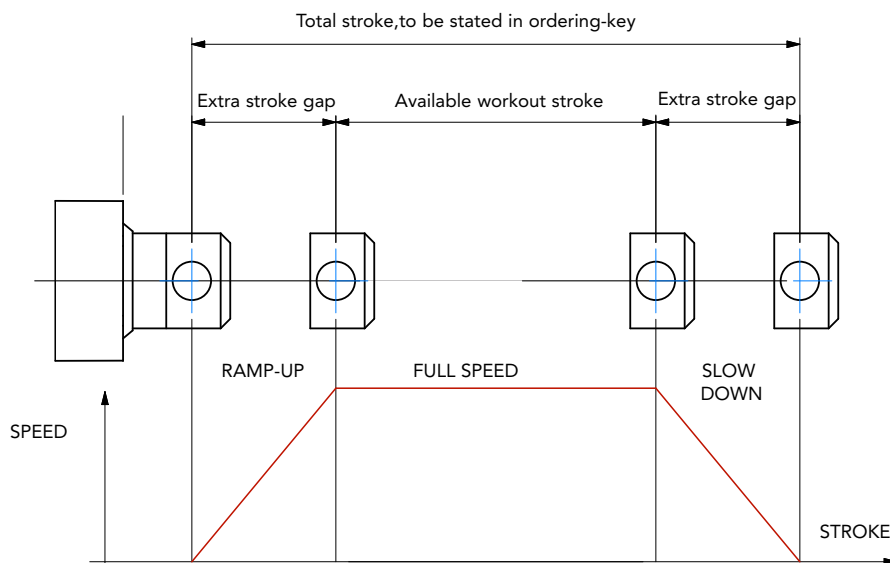

BUCKLING

When stroke is longer than 500mm, BUCKLING can be a risk: please check mounting with our offices and/or see usermanuals.

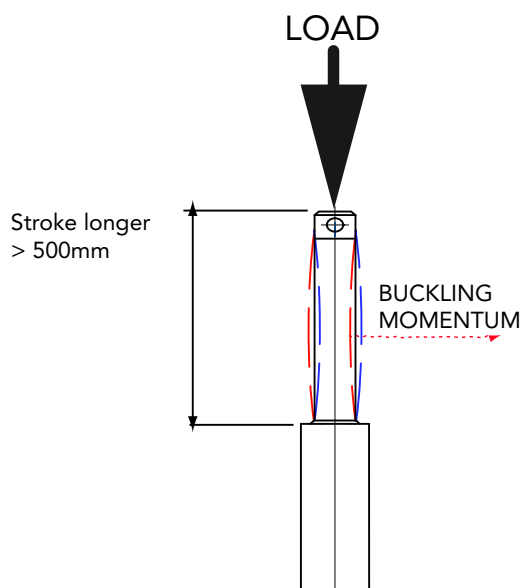

IMPORTANT:

Long strokes, even if load is low, can generate significant buckling momentums, as sketch slows. This happens when actuator is in its all-opened position: that's the reason why we recommend 100 mm extra-stroke. Pushtube will have this 100 mm-portion always inside the overtube, improving guidance against buckling.

For more information on this, contact our office.

EC3/0250/M06/CA-400/50-T-71-4-0,37/AB/E06/2FC1/POT01A/A3/
MODEL

 EC1 / EC2 / EC3 / EC4 / EC5
 EC1-VRS / EC2-VRS / EC3-VRS / EC4-VRS / EC5-VRS

STROKE

es. 250 mm = 0250

VERSION

 M01 / M02 / M03 / M04 / M05 / M06
 M00 = Not standard speed
 Flanged Version: indicate reduction ratio and screw pitch

MOTOR

 Advise only if with motor: version, voltage, type, size, n°pole, power
 With motorflange only put 0
 With special motorflange put: PD

AC MOTOR OPTIONS

 Motorflange: for motorflange version only advise size - i.e.for IEC80 B14 put 80B14
 Protection Degree: IP65, for selfbrake motor IP54 standard
 Brake type: for brakemotors only (es. FECA)
 Options: Advise if needed (es. AB 2'shaft)

ENCODER

Options pg.76 None: Leave blank

LIMIT SWITCHES

2FC1

POTENTIOMETER

POT01A (1Kohm) POT10A (10Kohm) None: Leave blank

FRONT END

A3 = Yoke + Clip A4 = Rod end A7 = Male threaded pin

NOTE: COMPLETE THE ORDERING KEY ADDING THE OPTIONS YOU CAN FIND IN THE "ACCESSORIES AND OPTIONS" SECTION
